



# VENTO Expert Duo A30-1 Pro

Heat recovery single-room units

- Air flow in heat recovery mode: 10
- Sound pressure level LpA at 3 m: 34
- Sound pressure level LpA at 1 m: 43
- Heat exchanger type: Reversible
- Sound insulation
- Motor type: EC
- Control: Remote Control
- Casing material: Plastic
- Humidity sensor: Optional
- CO2 sensor: Optional
- VOC sensor: Optional
- PM2.5 sensor: Optional

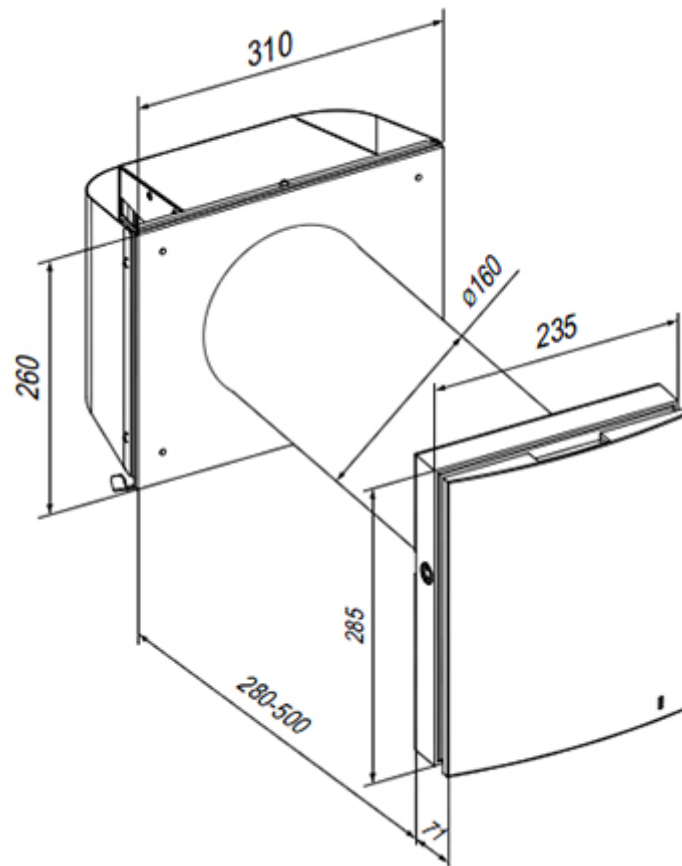

	Unit of measurement	VENTO Expert Duo A30-1 Pro		
Speed	-	3		
Minimum supply voltage	V	100		
Maximum supply voltage	V	240		
Power supply frequency	Hz	50/60		
Rated power	W	2.00	3.70	6.40
Unit current	A	0.027	0.043	0.067
Air flow in ventilation mode	m <sup>3</sup> /h	10		
Air flow in heat recovery mode	m <sup>3</sup> /h	10		
Sound pressure level LpA at 3 m	dB(A)	24	31	34
Sound pressure level LpA at 1 m	dB(A)	33	40	43
Heat recovery efficiency, max	%	85		
Heat exchanger type	-	Reversible		
Transported air temperature (max)	°C	40		
Transported air temperature (min)	°C	-15		
Ambient air temperature min	°C	1		
Ambient air temperature max	°C	40		
Ambient air humidity max	%	65		
Ingress protection rating	-	IP24		

## Dimensions



## Accessories

### CO2 sensors

Name	Photo	Description
<a href="#">CD-1</a>		CO2 sensors
<a href="#">CD-2</a>		CO2 sensors