



Trio One 100

Low noise and low power exhaust axial fan

- Maximum airflow: 95
- Sound pressure level LpA at 3 m: 27
- Motor type: AC
- Casing material: Plastic
- Backdraft protection: Backdraft damper

	Unit of measurement	Trio One 100
Connected air duct size	mm	100
Speed	-	1
Minimum supply voltage	V	220
Maximum supply voltage	V	240
Power supply frequency	Hz	50
Rated power	W	8
Unit current	A	0.05
Maximum airflow	m ³ /h	95
Sound pressure level LpA at 3 m	dB(A)	27
Weight	kg	0.45
Ambient air temperature min	°C	1
Ambient air temperature max	°C	40
Ingress protection rating	-	IP44 Zone 1

Dimensions

a	c	Ø d	e
150	79	99	23

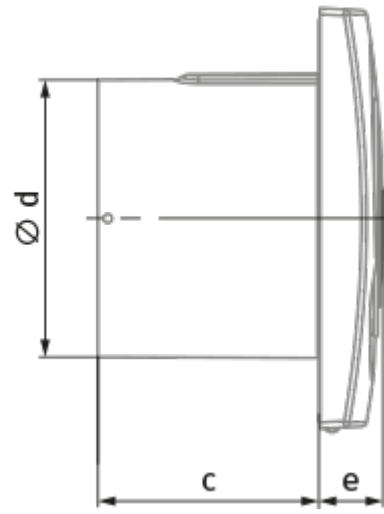
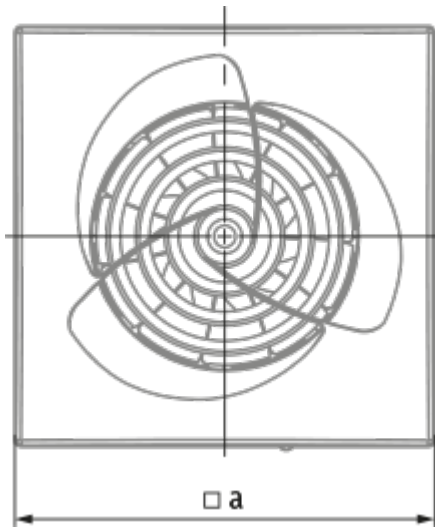

Ecodesign



Trademark	Blauberg					
Model	Trio One 100					
Specific energy consumption (SEC) (kWh/(m ² /a))	Cold		Average		Warm	
	-30.9	B	-14.5	E	-5.1	F
Type of ventilation unit	Unidirectional					
Type of drive installed	Single speed					
Type of heat recovery system	None					
Maximum flow rate (m ³ /h)	95					
Electric power input (W)	8					
Reference flow rate (m ³ /s)	0.018					
Specific power input (SPI) (W/(m ³ /h))	0.084					
Control typology	Manual control					
Maximum external leakage rates (%)	2.7					
Declared typology	RVU UVU					
Sound power level (dB(A))	47					
The annual electricity consumption (AEC) (kWh/a)	Cold	Average		Warm		
	105	105		105		
The annual heating saved (AHS) (kWh/a)	Cold	Average		Warm		
	3355	1715		776		