



## Q-Matic 100 TR

Fans with an innovative mixed flow impeller, with automatic louver shutters for exhaust ventilation

- Maximum airflow: 90
- Sound pressure level LpA at 3 m: 25
- Motor type: AC
- Impeller type: Mixed-flow
- Casing material: Plastic
- Timer: Turn off timer, Turn on timer

	Unit of measurement	Q-Matic 100 TR
Connected air duct size	mm	100
Speed	-	1
Minimum supply voltage	V	220
Maximum supply voltage	V	240
Power supply frequency	Hz	50
Rated power	W	11
Unit current	A	0.056
Maximum airflow	m <sup>3</sup> /h	90
Sound pressure level LpA at 3 m	dB(A)	25
Weight	kg	0.63
Ambient air temperature min	°C	1
Ambient air temperature max	°C	40
Ingress protection rating	-	IP24

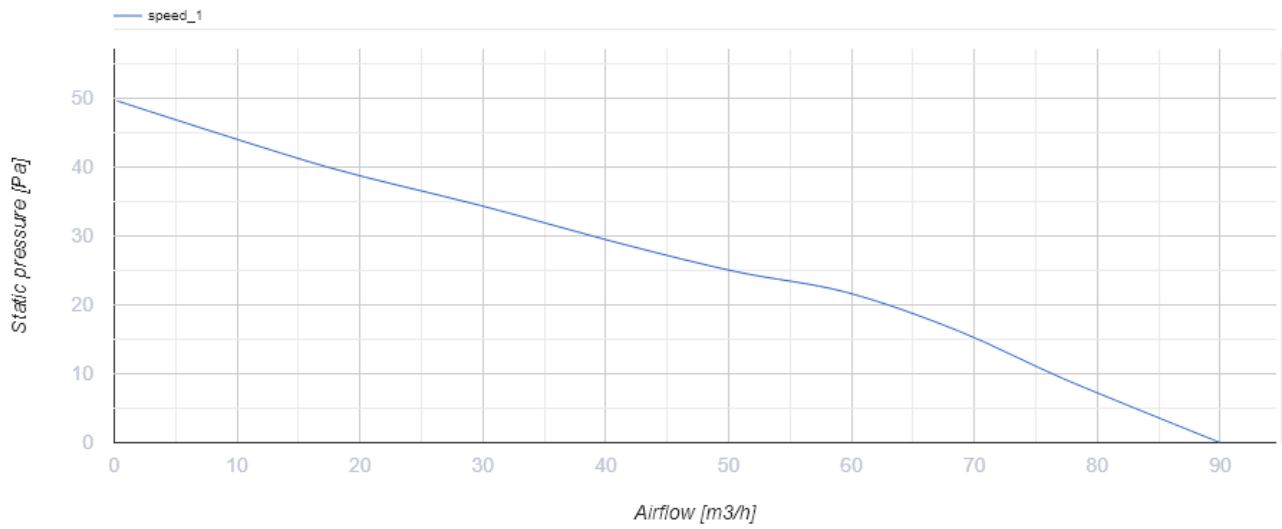

## Dimensions

Ø D	L	L1	W
99	110	29	168

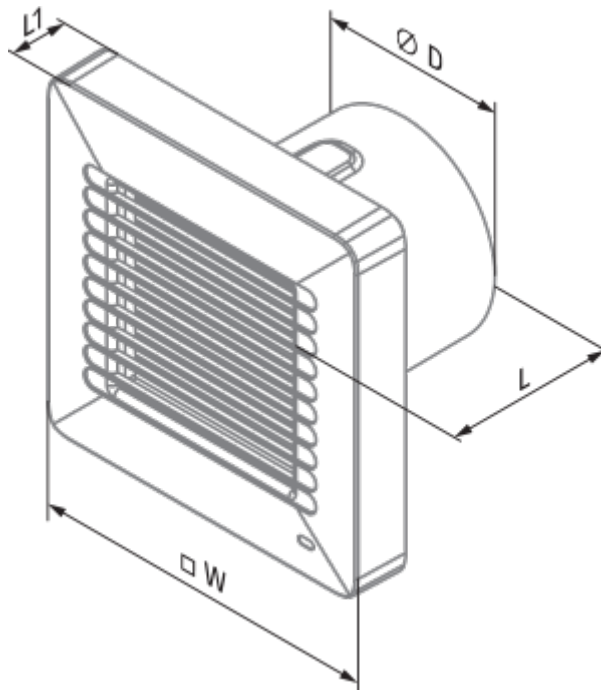

## Ecodesign

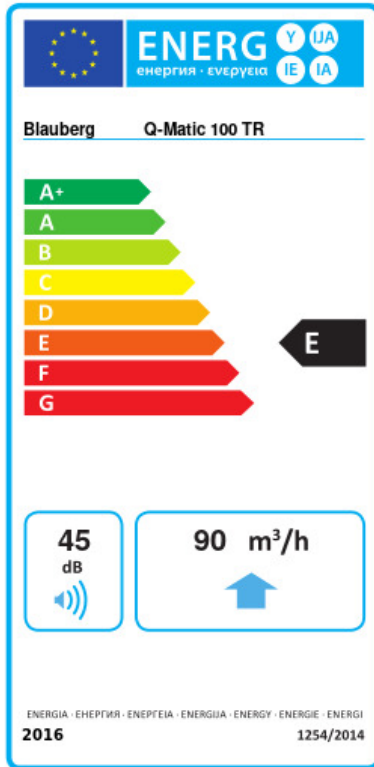

Trademark	Blaubeerg					
Model	Q-Matic 100 TR					
Specific energy consumption (SEC) (kWh/(m²/a))	Cold	Average		Warm		
	-30.1	B	-13.7	E	-4.3	F
Type of ventilation unit	Unidirectional					
Type of drive installed	Single speed					
Type of heat recovery system	None					
Maximum flow rate (m³/h)	90					
Electric power input (W)	10					
Reference flow rate (m³/s)	0.018					
Specific power input (SPI) (W/(m³/h))	0.111					
Control typology	Manual control					
Maximum external leakage rates (%)	2.7					
Declared typology	RVU UVU					
Sound power level (dB(A))	45					
The annual electricity consumption (AEC) (kWh/a)	Cold	Average		Warm		
	139	139		139		
The annual heating saved (AHS) (kWh/a)	Cold	Average		Warm		
	3355	1715		776		