



# Freshbox E1-100 WiFi

Single-room air handling units

- Power of electrical reheater: 350
- Maximum airflow: 100
- Sound pressure level LpA at 3 m: 39
- Heat recovery efficiency: 98
- Heat exchanger type: Counter flow
- Sound insulation
- Motor type: EC
- Bypass: Auto
- Preheater: Electric
- Control: Built-in control panel
- Casing material: Coated steel
- Temperature sensor: Built-in

	Unit of measurement	Freshbox E1-100 WiFi				
Connected air duct size	mm	100				
Speed	-	5				
Minimum supply voltage	V	230				
Maximum supply voltage	V	230				
Power supply frequency	Hz	50/60				
Rated power	W	20	23	29	37	53
Power of electrical reheater	W	350				
Unit current	A	0.4				
Maximum airflow	m <sup>3</sup> /h	30	44	60	75	100
Sound pressure level LpA at 3 m	dB(A)	13	20	27	33	39
Heat recovery efficiency	%	98	95	92	90	89
Heat exchanger type	-	Counter flow				
Heat exchanger material	-	Polystyrene				
Weight	kg	31				
Transported air temperature (max)	°C	40				
Transported air temperature (min)	°C	-20				
Ambient air temperature min	°C	1				
Ambient air temperature max	°C	40				
Ambient air humidity max	%	70				
Ingress protection rating	-	IP22				

Ingress protection rating of the drive	-	IP44
--	---	------

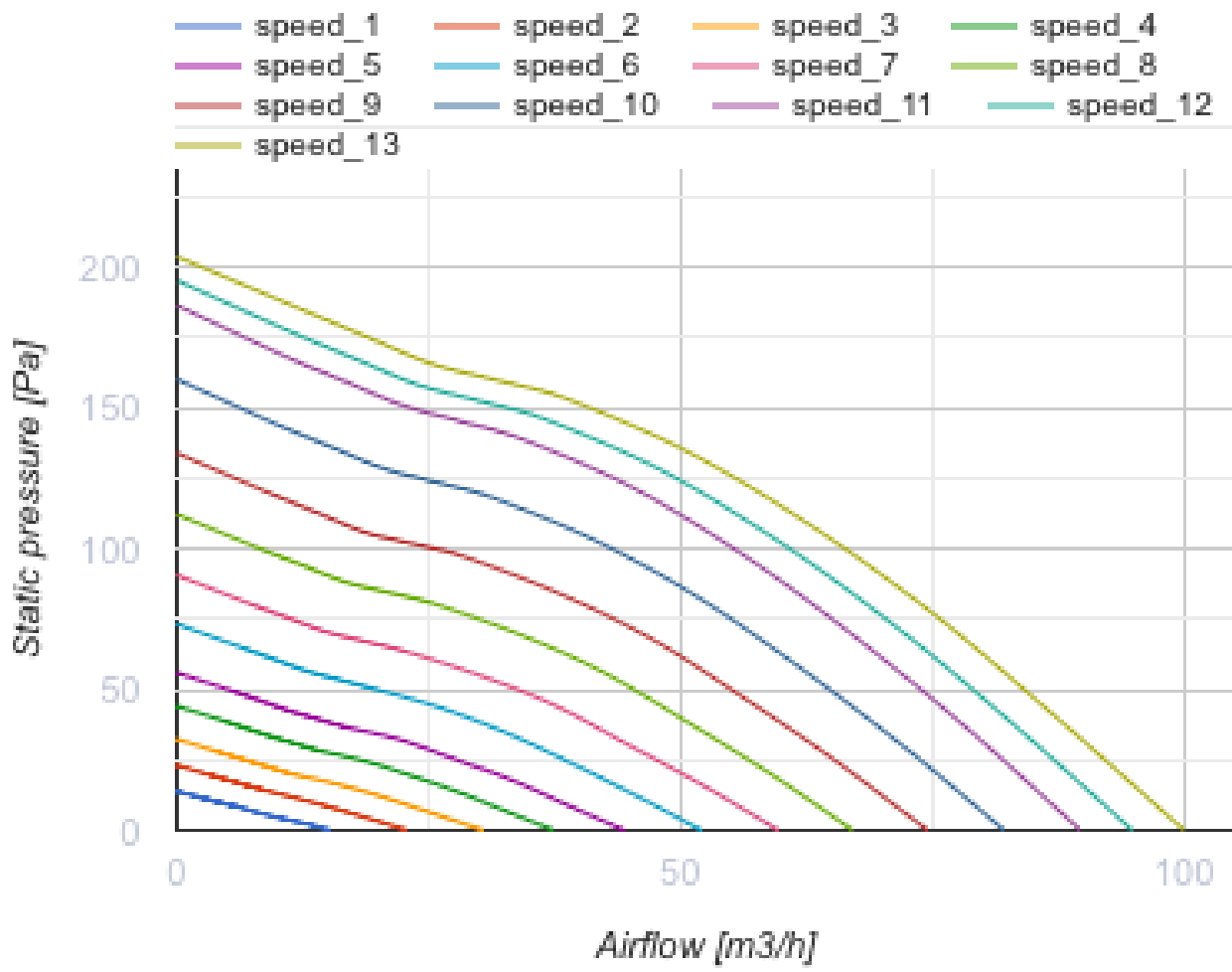

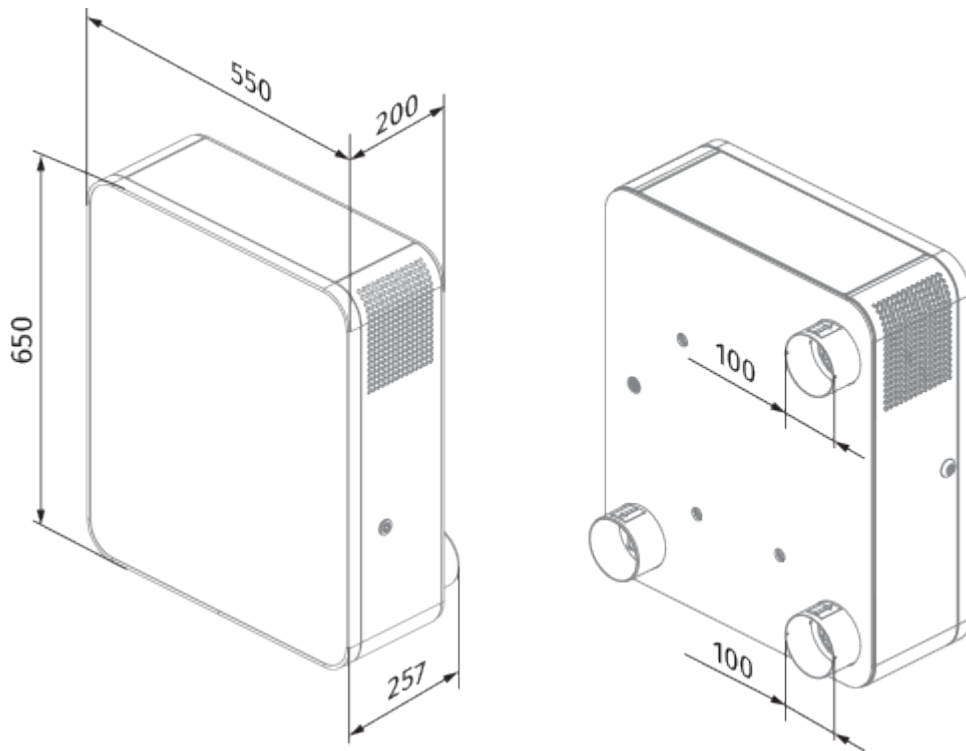

**Dimensions**



## Accessories

### CO2 sensors

Name	Photo	Description
<a href="#">CD-1</a>		CO2 sensors
<a href="#">CD-2</a>		CO2 sensors

### Other accessories

Name	Photo	Description
EH Freshbox 100		Electric heater