



Freshbox E-100 ERV

Single-room air handling units

- Power of electrical preheater: 700
- Maximum airflow: 100
- Sound pressure level LpA at 3 m: 39
- Heat recovery efficiency: 90
- Heat exchanger type: Counter flow
- Extract filter: G4
- Supply filter: G4, F8 (Option: F8 C, H13)
- Sound insulation
- Motor type: EC
- Enthalpy heat exchanger
- Bypass: Auto
- Reheater: Electric
- Control: Remote Control
- Casing material: Coated steel
- Temperature sensor: Built-in

	Unit of measurement	Freshbox E-100 ERV		
Connected air duct size	mm	100		
Speed	-	3		
Phases	-	1		
Minimum supply voltage	V	230		
Maximum supply voltage	V	230		
Power supply frequency	Hz	50/60		
Rated power	W	12	21	45
Power of electrical preheater	W	700		
Unit current	A	0.4		
Maximum airflow	m ³ /h	30	60	100
rotation speed at 50hz	-	2200		
Sound pressure level LpA at 3 m	dB(A)	13	27	39
Heat recovery efficiency	%	83	90	86
Heat recovery efficiency, max	%	90		
Heat exchanger type	-	Counter flow		
Heat exchanger material	-	Enthalpy		
Weight	kg	31		
Extract filter	-	G4		
Supply filter	-	G4, F8 (Option: F8 C, H13)		
Transported air temperature (max)	°C	40		
Transported air temperature (min)	°C	-20		

Ambient air temperature min	°C	1
Ambient air temperature max	°C	40
Ambient air humidity max	%	70
Ingress protection rating	-	IP22
Ingress protection rating of the drive	-	IP44

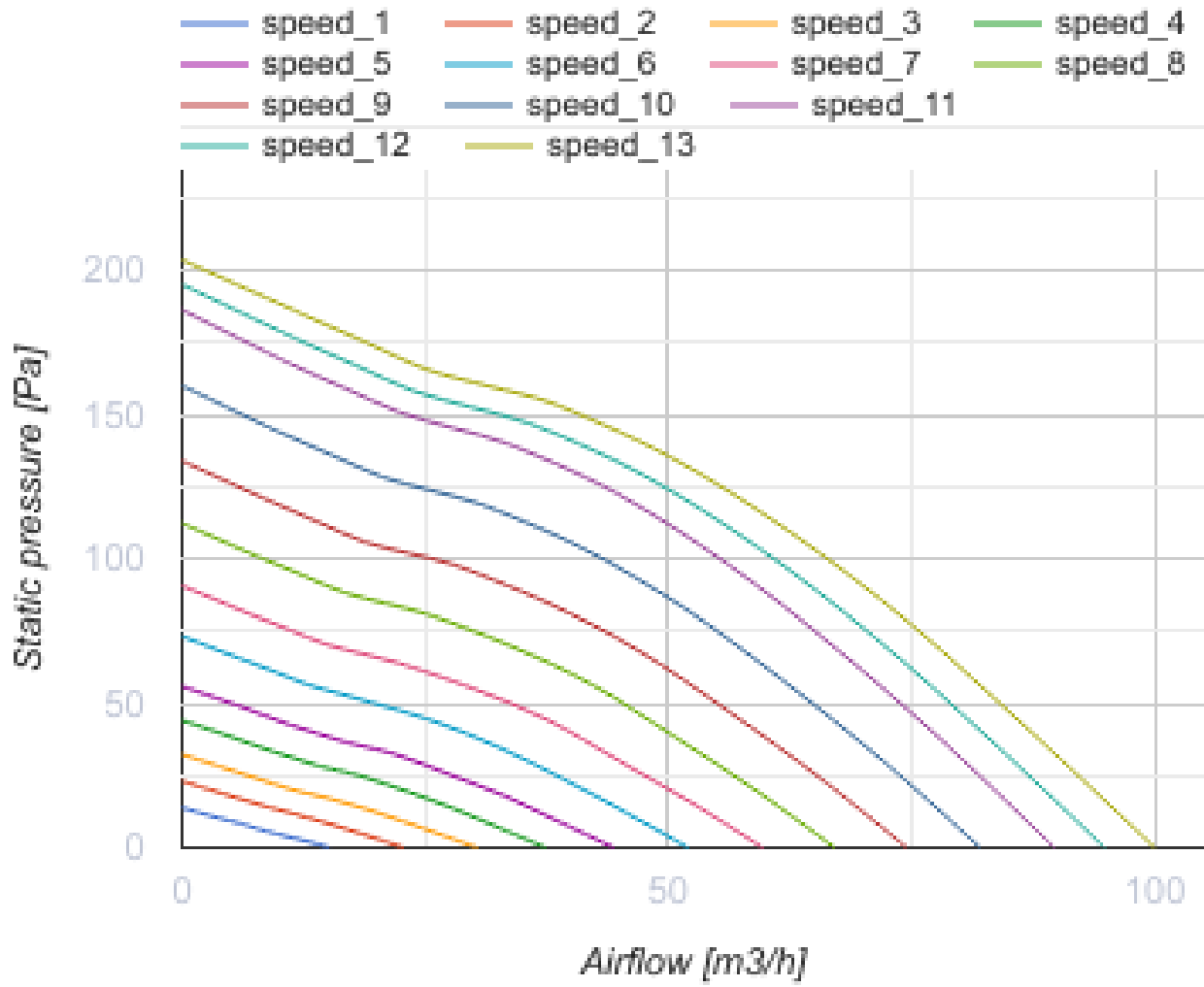

Dimensions

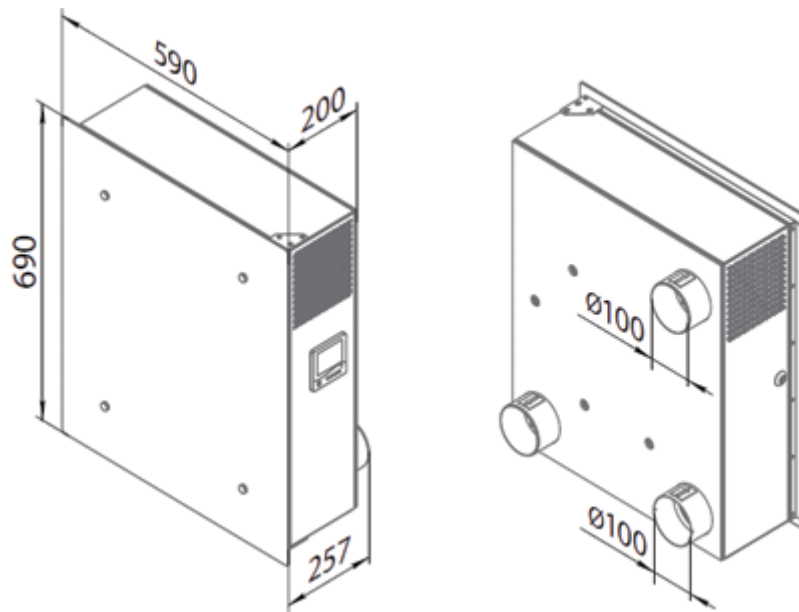



Accessories

Other accessories

Name	Photo	Description
EH Freshbox 100		Electric heater

Other accessories

Name	Photo	Description
CD-1		CO2 sensors
CD-2		CO2 sensors