



# Freshbox E-100 black

Single-room air handling units

- Power of electrical preheater: 700
- Maximum airflow: 100
- Sound pressure level LpA at 3 m: 39
- Heat recovery efficiency: 98
- Heat exchanger type: Counter flow
- Extract filter: G4
- Supply filter: G4, F8 (опция: F8 C, H13), G4, F8 (Option: F8 C, H13)
- Sound insulation
- Motor type: EC
- Bypass: Auto
- Reheater: Electric
- Control: Remote Control
- Casing material: Coated steel
- Temperature sensor: Built-in

|                                   | Unit of measurement | Freshbox E-100 black                                  |    |     |
|-----------------------------------|---------------------|-------------------------------------------------------|----|-----|
| Connected air duct size           | mm                  | 100                                                   |    |     |
| Speed                             | -                   | 3                                                     |    |     |
| Phases                            | -                   | 1                                                     |    |     |
| Minimum supply voltage            | V                   | 230                                                   |    |     |
| Maximum supply voltage            | V                   | 230                                                   |    |     |
| Power supply frequency            | Hz                  | 50/60                                                 |    |     |
| Rated power                       | W                   | 12                                                    | 21 | 45  |
| Power of electrical preheater     | W                   | 700                                                   |    |     |
| Unit current                      | A                   | 0.4                                                   |    |     |
| Maximum airflow                   | m <sup>3</sup> /h   | 30                                                    | 60 | 100 |
| rotation speed at 50hz            | -                   | 2200                                                  |    |     |
| Sound pressure level LpA at 3 m   | dB(A)               | 13                                                    | 27 | 39  |
| Heat recovery efficiency          | %                   | 98                                                    | 92 | 89  |
| Heat recovery efficiency, max     | %                   | 98                                                    |    |     |
| Heat exchanger type               | -                   | Counter flow                                          |    |     |
| Heat exchanger material           | -                   | Polystyrene                                           |    |     |
| Weight                            | kg                  | 31                                                    |    |     |
| Extract filter                    | -                   | G4                                                    |    |     |
| Supply filter                     | -                   | G4, F8 (опция: F8 C, H13), G4, F8 (Option: F8 C, H13) |    |     |
| Transported air temperature (max) | °C                  | 40                                                    |    |     |
| Transported air temperature (min) | °C                  | -20                                                   |    |     |

|                                        |    |      |
|----------------------------------------|----|------|
| Ambient air temperature min            | °C | 1    |
| Ambient air temperature max            | °C | 40   |
| Ambient air humidity max               | %  | 70   |
| Ingress protection rating              | -  | IP22 |
| Ingress protection rating of the drive | -  | IP44 |

## Dimensions

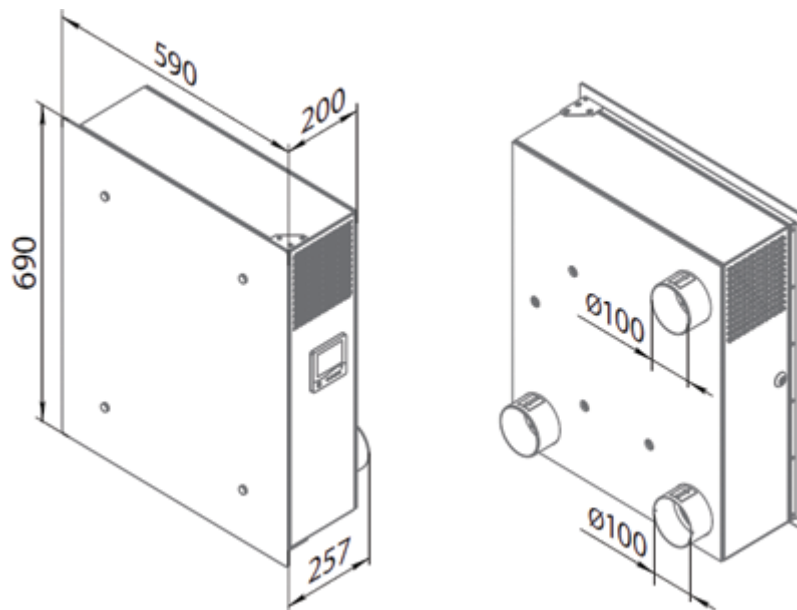



## Accessories

### Other accessories

| Name            | Photo                                                                               | Description     |
|-----------------|-------------------------------------------------------------------------------------|-----------------|
| EH Freshbox 100 |  | Electric heater |

### CO2 sensors

| Name                 | Photo                                                                               | Description |
|----------------------|-------------------------------------------------------------------------------------|-------------|
| <a href="#">CD-1</a> |  | CO2 sensors |
| <a href="#">CD-2</a> |  | CO2 sensors |