



# Freshbox 110

Decentralized supply and exhaust unit with heat recovery

- Maximum airflow: 100
- Sound pressure level LpA at 3 m: 31
- Sound pressure level LpA at 1 m: 40
- Heat recovery efficiency: 93
- Heat exchanger type: Counter flow
- Sound insulation
- Motor type: EC
- Bypass: Auto
- Control: Remote Control
- Casing material: Galvanized steel
- Humidity sensor: Built-in
- Temperature sensor: Built-in

	Unit of measurement	Freshbox 110		
Connected air duct size	mm	100		
Speed	-	3		
Minimum supply voltage	V	230		
Maximum supply voltage	V	230		
Power supply frequency	Hz	50/60		
Rated power	W	10	15	31
Unit current	A	0.26		
Maximum airflow	m <sup>3</sup> /h	30	60	100
Sound pressure level LpA at 3 m	dB(A)	10	21	31
Sound pressure level LpA at 1 m	dB(A)	20	30	40
Heat recovery efficiency	%	93	87	84
Heat exchanger type	-	Counter flow		
Heat exchanger material	-	Polystyrene		
Weight	kg	20		
Transported air temperature (max)	°C	40		
Transported air temperature (min)	°C	-15		
Ambient air temperature min	°C	1		
Ambient air temperature max	°C	40		
Ambient air humidity max	%	60		
Ingress protection rating	-	IP20		

Ingress protection rating of the drive	-	IP44
--	---	------

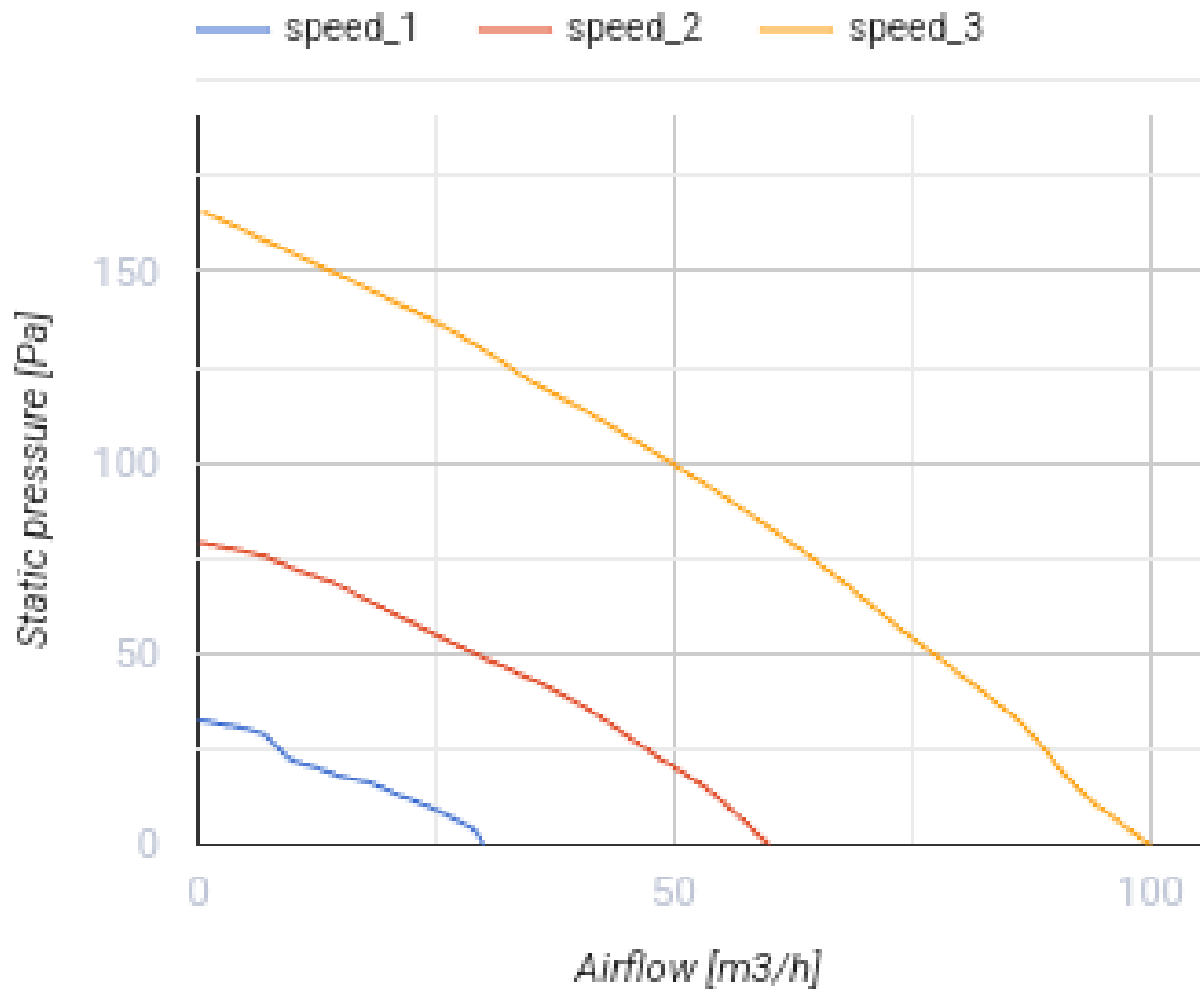

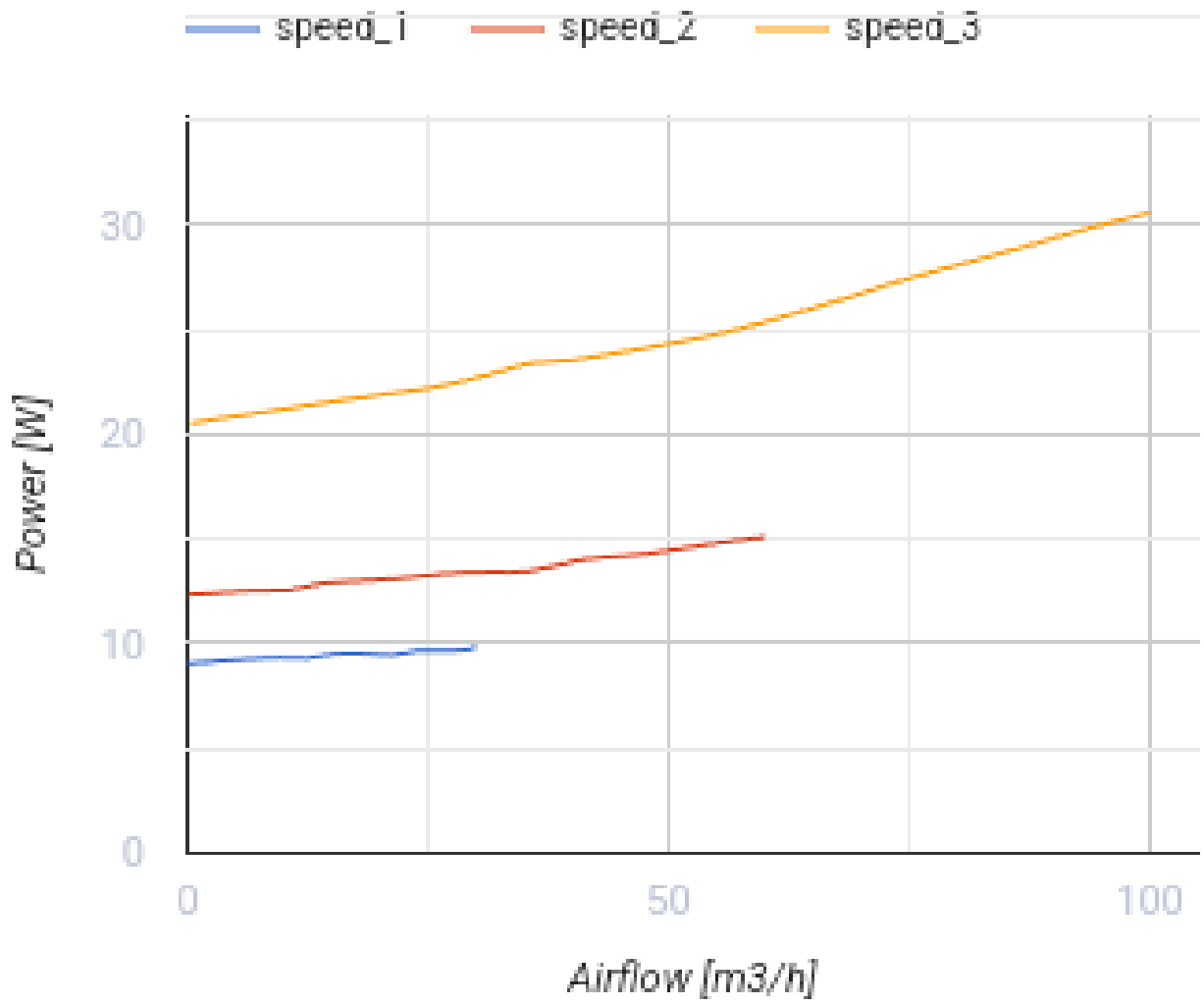

## Dimensions

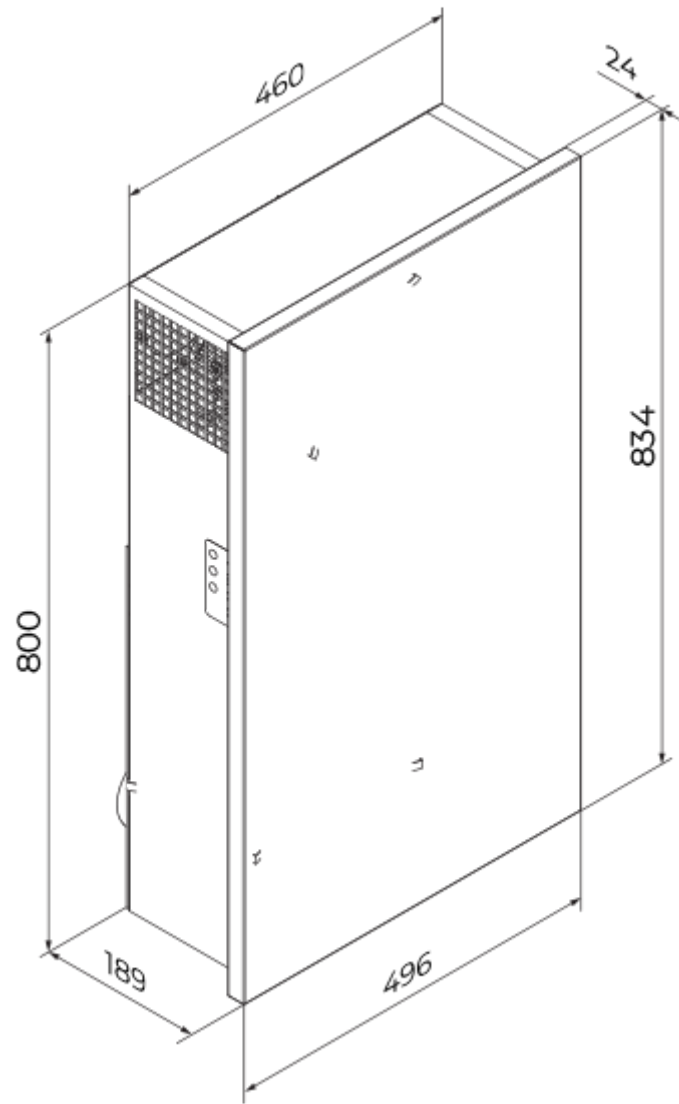

## Ecodesign

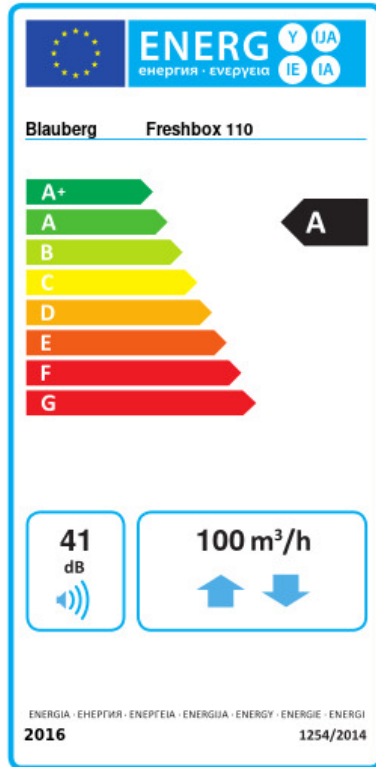

Trademark	Blaubeerg					
Model	Freshbox 110					
Specific energy consumption (SEC) (kWh/(m <sup>2</sup> /a))	Cold		Average		Warm	
	-79.7	A+	-41	A	-16.3	E
Type of ventilation unit	Bidirectional					
Type of drive installed	3-speed					
Type of heat recovery system	Recuperative					
Thermal efficiency of heat recovery (%)	87					
Maximum flow rate (m <sup>3</sup> /h)	100					
Electric power input (W)	30.6					
Reference flow rate (m <sup>3</sup> /s)	0.017					
Specific power input (SPI) (W/(m <sup>3</sup> /h))	0.252					
Control typology	Local demand control					
Maximum internal leakage rates (%)	1.7					
Maximum external leakage rates (%)	4.7					
Airflow sensitivity at +20 Pa and -20 Pa (%)	0					
Declared typology	RVU BVU					
Sound power level (dB(A))	41					
The annual electricity consumption (AEC) (kWh/a)	Cold		Average		Warm	
	764		227		182	
The annual heating saved (AHS) (kWh/a)	Cold		Average		Warm	
	9007		4604		2082	

## Accessories

### Other accessories

Name	Photo	Description
<a href="#">CD-1</a>		CO2 sensors
<a href="#">CD-2</a>		CO2 sensors

[CD-3](#)**Other accessories**

Name	Photo	Description
EH Freshbox 100		Electric heater