

# Box-R 80 V3

Centrifugal inline fans

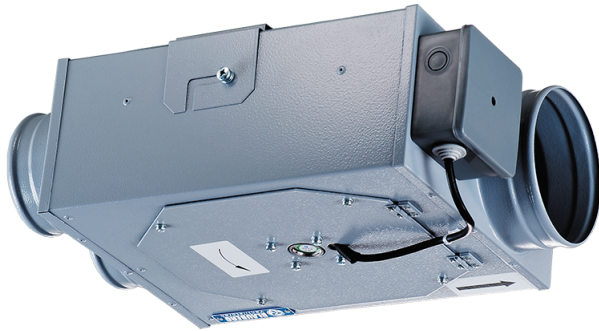

- Maximum airflow: 162
- Sound pressure level LpA at 3 m: 43
- Motor type: AC
- Impeller type: Centrifugal backward curved blades
- Casing material: Coated steel
- Installation in any position

	Unit of measurement	Box-R 80 V3		
Connected air duct size	mm	80		
Speed	-	3		
Minimum supply voltage	V	230		
Maximum supply voltage	V	230		
Power supply frequency	Hz	50		
Rated power	W	20	26	45
Unit current	A	0.32	0.34	0.4
Maximum airflow	m <sup>3</sup> /h	88	130	162
Sound pressure level LpA at 3 m	dB(A)	32	35	43
Weight	kg	2		
Transported air temperature (max)	°C	50		
Ingress protection rating	-	IPX4		
Ingress protection rating of the drive	-	IP44		

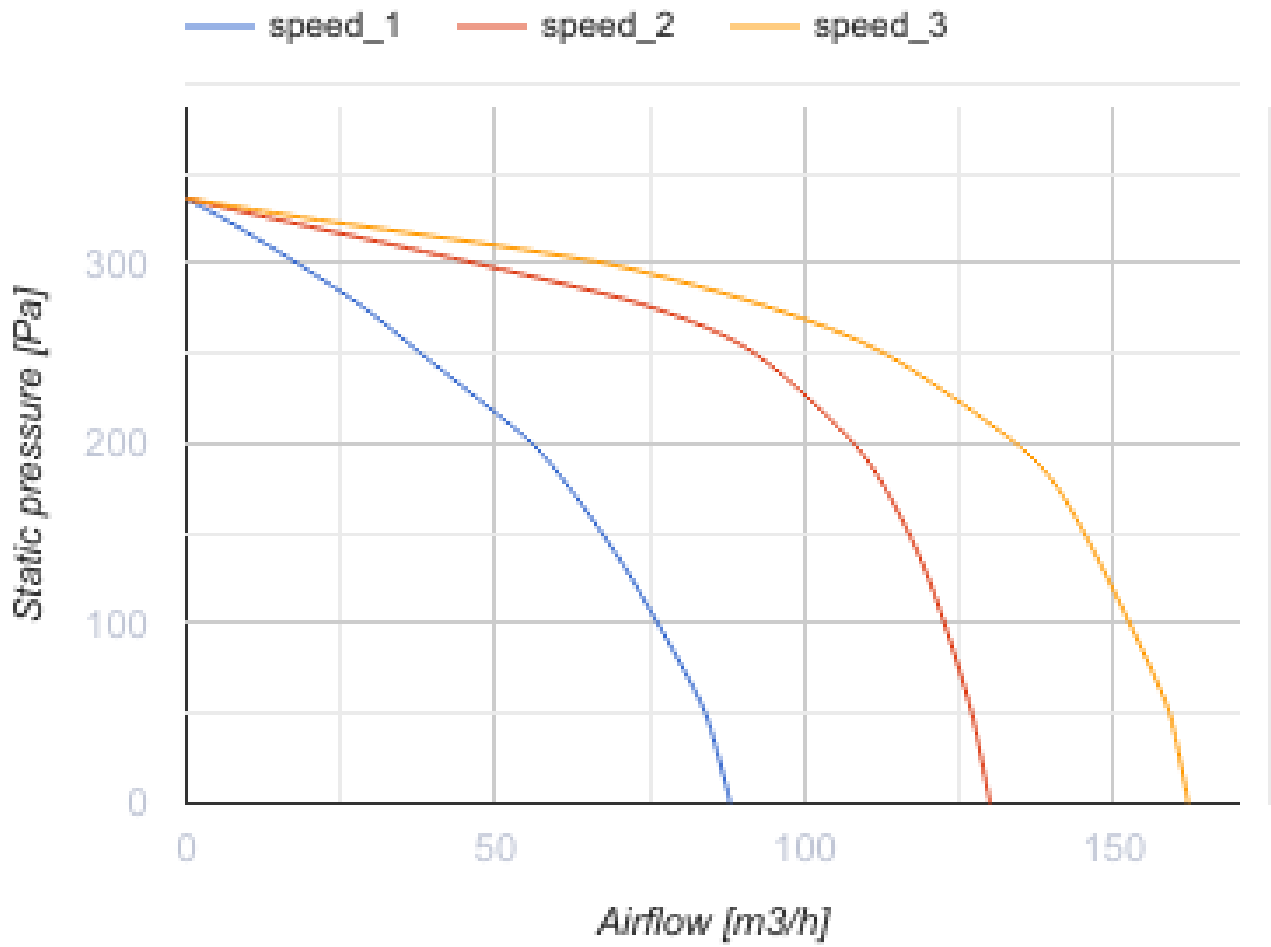

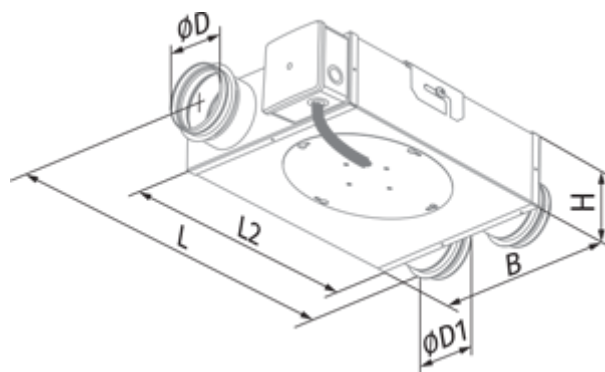

## Dimensions

ØD	ØD1	B	H	L	L2
79	79	260	90	352	253







## Accessories

### Other accessories

Name	Photo	Description
<a href="#">MLCD E2</a>		Room temperature regulator
<a href="#">CDP-2/5</a>		Multi-speed switch
<a href="#">CDP-3/5</a>		Multi-speed switch

### Other accessories

Name	Photo	Description
<a href="#">TE / TI 1.5</a>		Timers
<a href="#">HSE / HSI 1.5</a>		Sensors
<a href="#">LSE / LSI 1.5</a>		Sensors
<a href="#">IRSE / IRSI 1.5</a>		Sensors