

Box-R 100 V3

Centrifugal inline fans

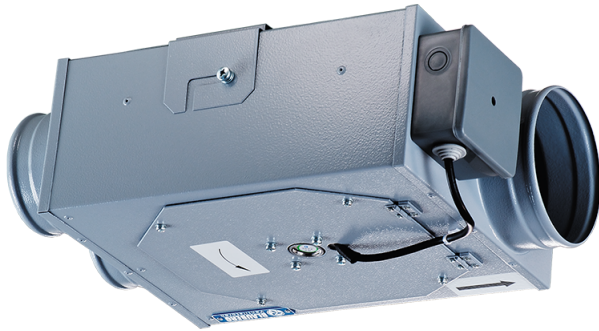

- Maximum airflow: 176
- Sound pressure level LpA at 3 m: 44
- Motor type: AC
- Impeller type: Centrifugal backward curved blades
- Casing material: Coated steel
- Installation in any position

	Unit of measurement	Box-R 100 V3		
Connected air duct size	mm	100		
Speed	-	3		
Minimum supply voltage	V	230		
Maximum supply voltage	V	230		
Power supply frequency	Hz	50		
Rated power	W	20	26	45
Unit current	A	0.32	0.34	0.4
Maximum airflow	m ³ /h	97	138	176
Sound pressure level LpA at 3 m	dB(A)	33	36	44
Weight	kg	3.37		
Transported air temperature (max)	°C	50		
Ingress protection rating	-	IPX4		
Ingress protection rating of the drive	-	IP44		

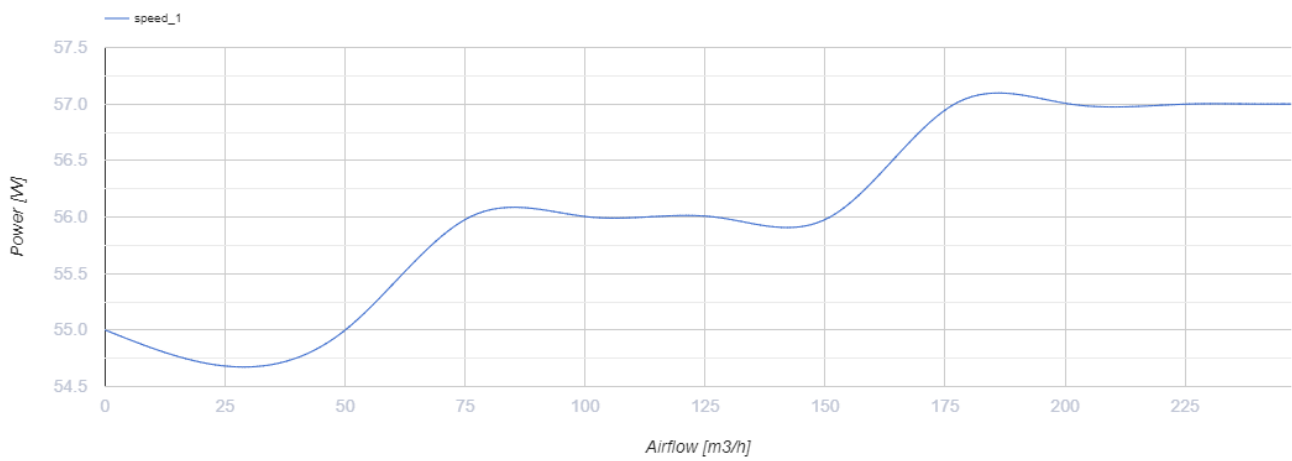
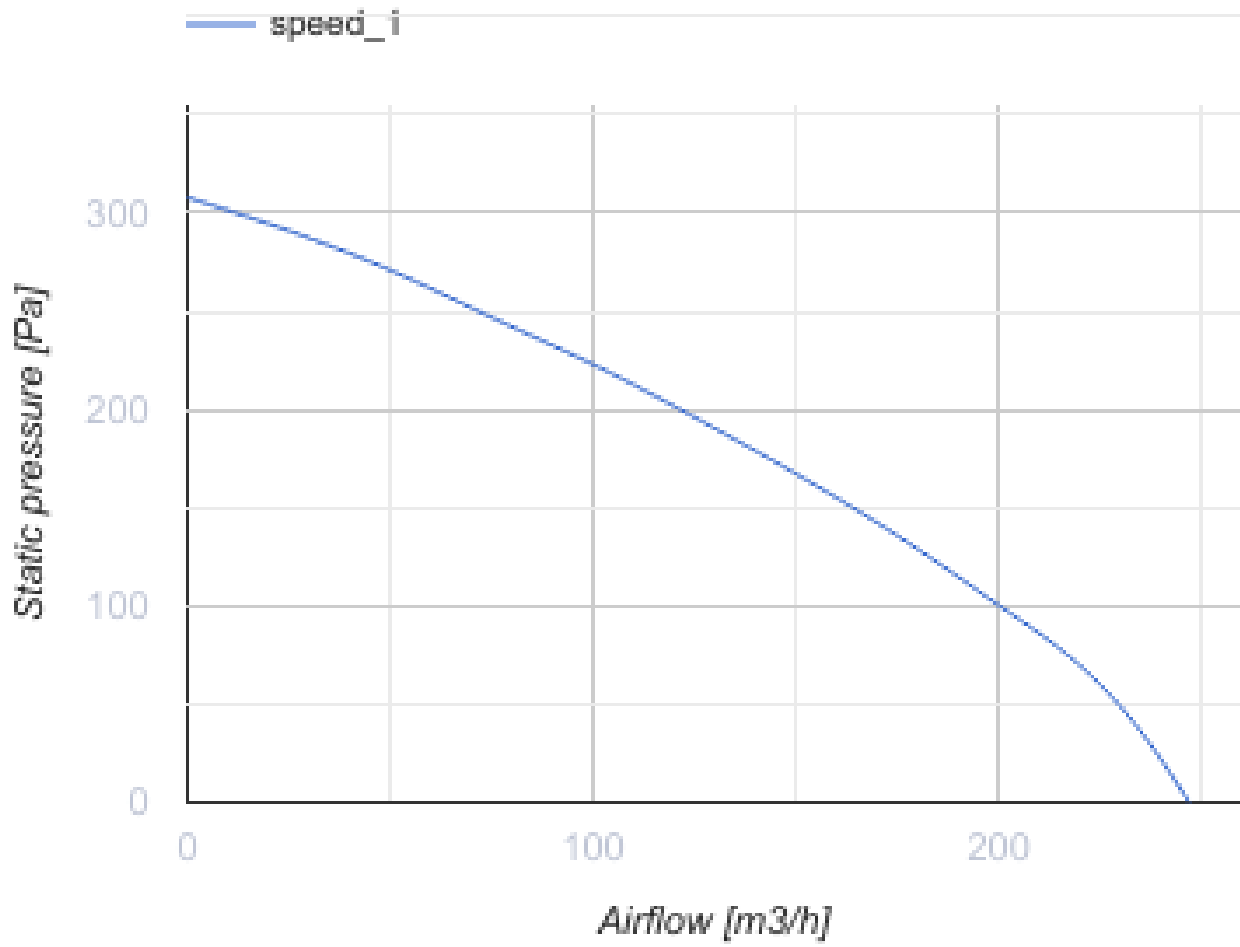

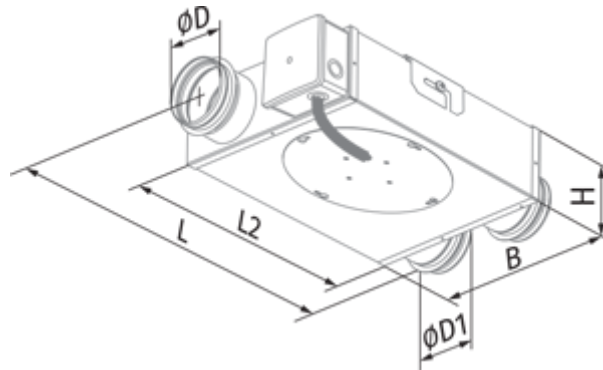

Dimensions

ØD	ØD1	B	H	L	L2
99	99	260	110	352	253







Accessories

Other accessories

Name	Photo	Description
MLCD E2		Room temperature regulator
CDP-2/5		Multi-speed switch
CDP-3/5		Multi-speed switch

Other accessories

Name	Photo	Description
TE / TI 1.5		Timers
HSE / HSI 1.5		Sensors
LSE / LSI 1.5		Sensors
IRSE / IRSI 1.5		Sensors