

AIR HANDLING UNIT

KOMFORT Roto EC D/D₂/DE/D₂E250

KOMFORT Roto EC D/D₂/DE/D₂E350

KOMFORT Roto EC D/DE650

EN

USER'S MANUAL

CONTENTS

Safety requirements.....	2
Purpose.....	4
Delivery set.....	4
Designation key.....	4
Technical data.....	5
Design and operating principle	10
Installation and set-up.....	11
Connection to power mains	13
Technical maintenance.....	15
Storage and transportation regulations.....	16
Manufacturer's warranty	17
Certificate of acceptance.....	19
Seller information.....	19
Installation certificate.....	19
Warranty card.....	19

This user's manual is a main operating document intended for technical, maintenance, and operating staff.

The manual contains information about purpose, technical details, operating principle, design, and installation of the KOMFORT Roto EC D/D2/DE/D2E250/350/650 unit and all its modifications.

Technical and maintenance staff must have theoretical and practical training in the field of ventilation systems and should be able to work in accordance with workplace safety rules as well as construction norms and standards applicable in the territory of the country.

SAFETY REQUIREMENTS

- Please read the user's manual carefully prior to installing and operating the unit.
- All user's manual requirements as well as the provisions of all the applicable local and national construction, electrical, and technical norms and standards must be observed when installing and operating the unit.
- The warnings contained in the user's manual must be considered most seriously since they contain vital personal safety information.
- Failure to follow the rules and safety precautions noted in this user's manual may result in an injury or unit damage.
- After a careful reading of the manual, keep it for the entire service life of the unit.
- While transferring the unit control, the user's manual must be turned over to the receiving operator.

UNIT INSTALLATION AND OPERATION SAFETY PRECAUTIONS

- Disconnect the unit from power mains prior to any installation operations.



- Unpack the unit with care.



- The unit must be grounded!



- While installing the unit, follow the safety regulations specific to the use of electric tools.



- Do not change the power cable length at your own discretion.
- Do not bend the power cable.
- Avoid damaging the power cable.
- Do not put any foreign objects on the power cable.

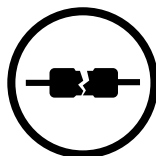

- Do not use damaged equipment or cables when connecting the unit to power mains.



- Do not touch the unit controls with wet hands.
- Do not carry out the installation and maintenance operations with wet hands.



- Do not allow children to operate the unit.



- Do not store any explosive or highly flammable substances in close proximity to the unit.

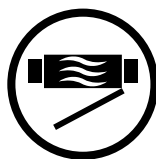

- Do not open the unit during operation.



- Do not block the air duct when the unit is switched on.

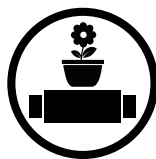

- Do not sit on the unit and avoid placing foreign objects on it.



- Do not lay the power cable of the unit in close proximity to heating equipment.

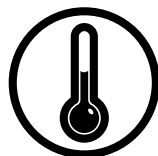

- Do not operate the unit outside the temperature range stated in the user's manual.
- Do not operate the unit in aggressive or explosive environments.



- Do not wash the unit with water.
- Protect the electric parts of the unit against ingress of water.

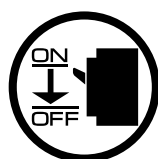

- Disconnect the unit from power mains prior to any technical maintenance.



- When the unit generates unusual sounds, odour, or emits smoke, disconnect it from power supply and contact the Seller.



- Do not direct the air flow produced by the unit towards open flame or ignition sources.



- In case of continuous operation of the unit, periodically check the security of mounting.

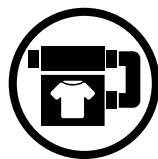

- Use the unit only for its intended purpose.



THE PRODUCT MUST BE DISPOSED SEPARATELY AT THE END OF ITS SERVICE LIFE.

DO NOT DISPOSE THE UNIT AS UNSORTED DOMESTIC WASTE.

PURPOSE

The unit is designed to ensure continuous mechanical air exchange in houses, offices, hotels, cafes, conference halls, and other utility and public spaces as well as to recover the heat energy contained in the air extracted from the premises to warm up the filtered stream of intake air.

The unit is not intended for organizing ventilation in swimming pools, saunas, greenhouses, summer gardens, and other spaces with high humidity.

Due to the ability to save heating energy by means of energy recovery, the unit is an important element of energy-efficient premises.

The unit is a component part and is not designed for stand-alone operation. It is rated for continuous operation.

Transported air must not contain any flammable or explosive mixtures, evaporation of chemicals, sticky substances, fibrous materials, coarse dust, soot and oil particles or environments favourable for the formation of hazardous substances (toxic substances, dust, pathogenic germs).



THE UNIT SHOULD NOT BE OPERATED BY CHILDREN OR PERSONS WITH REDUCED PHYSICAL, MENTAL, OR SENSORY CAPACITIES, OR THOSE WITHOUT THE APPROPRIATE TRAINING.

THE UNIT MUST BE INSTALLED AND CONNECTED ONLY BY PROPERLY QUALIFIED PERSONNEL AFTER THE APPROPRIATE BRIEFING.

THE CHOICE OF UNIT INSTALLATION LOCATION MUST PREVENT UNAUTHORISED ACCESS BY UNATTENDED CHILDREN.

DELIVERY SET

Name	Number
Air handling unit	1 pc.
User's manual	1 pc.
Control panel	1 pc.
Installation kit	1 pc.
Packing box	1 pc.

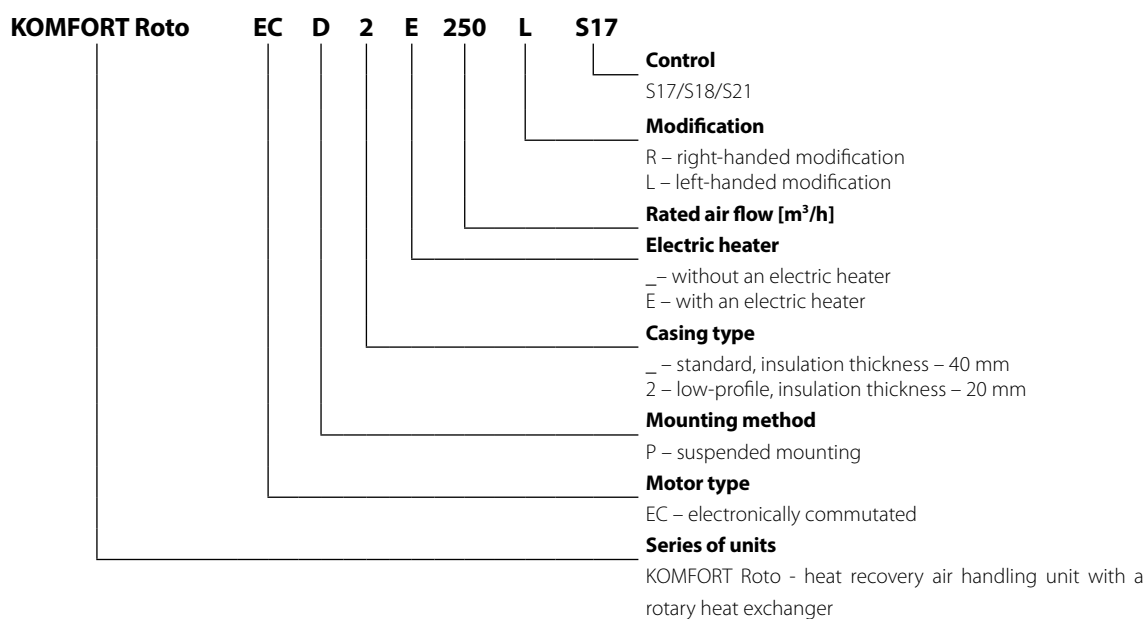
DESIGNATION KEY

TECHNICAL DATA

The unit is designed for indoor application with the ambient temperature ranging from +1 °C up to +40 °C and relative humidity up to 60 % without condensation. In cold, damp rooms, there is a possibility of freezing or condensation inside and outside the casing.

In order to prevent condensation on the internal walls of the unit, it is necessary that the surface temperature of the casing is 2-3 °C above the dew point temperature of the transported air.

The unit should be operated continuously, and in cases where ventilation is not necessary, reduce the air flow of the fans to a minimum (20%). This will ensure a favorable indoor climate and reduce the amount of condensation inside the unit, which can damage electronic components. Never use the unit for dehumidification, for example, of new buildings.

The unit is rated as a Class I electrical appliance.

Hazardous parts access and water ingress protection rating:

IP22 for the unit connected to the air ducts

IP44 for the unit motors

The unit design is constantly being improved, thus some models may be slightly different from those described in this manual.

KOMFORT Roto EC ... L

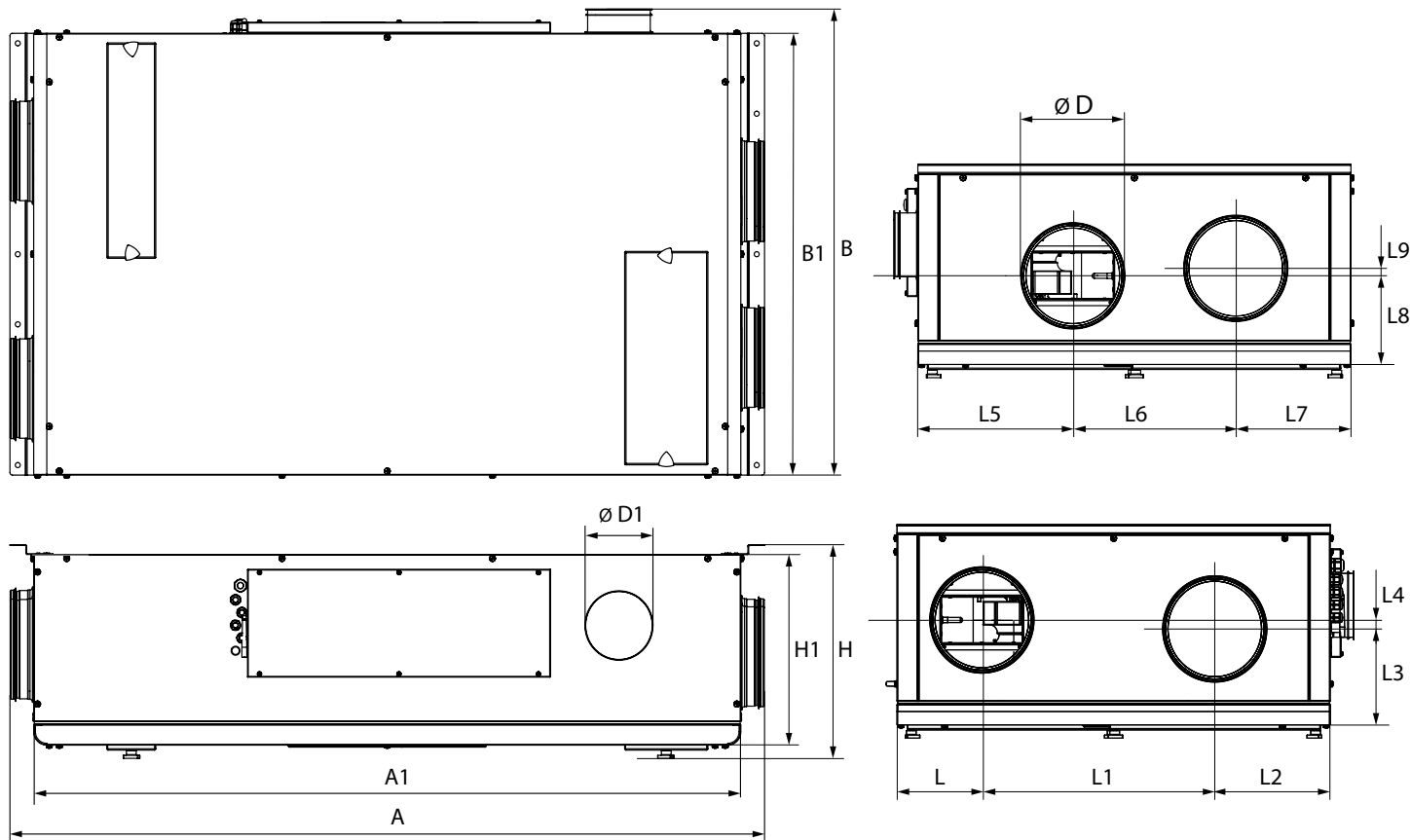

Model	Dimensions, mm																	
	$\varnothing D$	$\varnothing D1$	A	A1	B	B1	H	H1	L	L1	L2	L3	L4	L5	L6	L7	L8	L9
KOMFORT Roto EC D250	160	125	1098	1003	692	643	345	306	149	340	154	154	14	224	224	175	153	12
KOMFORT Roto EC DE250																		
KOMFORT Roto EC D2 250	160	125	1098	1003	667	619	268	225	122	342	155	134	2	204	250	164	126	9
KOMFORT Roto EC D2E250																		
KOMFORT Roto EC D350	160	125	1366	1270	833	770	367	320	160	405	206	162	41	296	269	206	162	19
KOMFORT Roto EC DE350																		
KOMFORT Roto EC D2 350	160	125	1457	1362	847	798	270	245	129	445	224	123	6	269	319	209	123	9
KOMFORT Roto EC D2E350																		
KOMFORT Roto EC D650	200	125	1541	1445	934	885	382	428	173	476	236	193	18	317	333	235	193	15
KOMFORT Roto EC DE650																		

KOMFORT Roto EC ... R

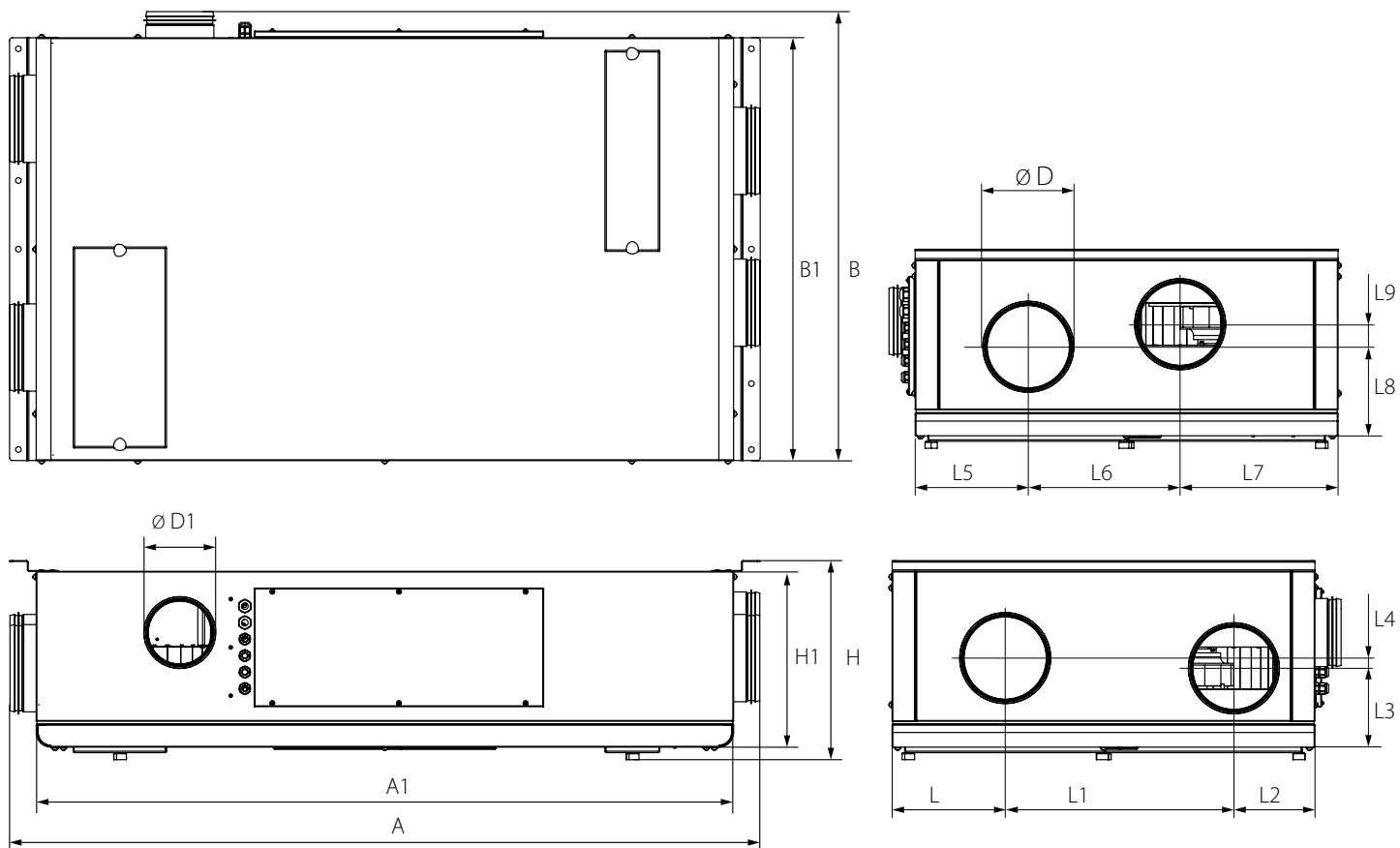

Model	Dimensions, mm																	
	$\varnothing D$	$\varnothing D1$	A	A1	B	B1	H	H1	L	L1	L2	L3	L4	L5	L6	L7	L8	L9
KOMFORT Roto EC D250	160	125	1098	1003	692	643	345	306	184	310	149	141	13	151	268	224	154	14
KOMFORT Roto EC DE250																		
KOMFORT Roto EC D2 250	160	125	1098	1003	667	619	268	225	164	335	119	117	9	155	250	212	123	4
KOMFORT Roto EC D2E250																		
KOMFORT Roto EC D350	160	125	1366	1270	833	770	367	320	206	417	147	144	19	207	276	287	160	41
KOMFORT Roto EC DE350																		
KOMFORT Roto EC D2 350	160	125	1457	1362	847	798	270	245	209	432	155	117	9	224	300	275	120	6
KOMFORT Roto EC D2E350																		
KOMFORT Roto EC D650	200	125	1541	1445	934	885	428	382	231	481	173	183	12	230	338	317	198	8
KOMFORT Roto EC DE650																		

TECHNICAL DATA

Parameters	KOMFORT Roto EC D2 250	KOMFORT Roto EC D2E250	KOMFORT Roto EC D250	KOMFORT Roto EC DE250
Unit voltage [V/50 (60) Hz]	1~ 230			
Maximum unit power (without a heater) [W]	128		135	
Maximum unit power (with a heater) [W]	-	828	-	835
Maximum unit current (without a heater) [A]	0.9		1.0	
Maximum unit current (with a heater) [A]	-	4.0	-	4.1
Maximum air flow [m ³ /h]	300		310	
RPM [min ⁻¹]	2200		2200	
Sound pressure level at 3 m distance [dBA]	23*		21*	
Maximum transported air temperature [°C]	from -25 up to +40			
Casing material	aluzinc			
Insulation	20 mm mineral wool		40 mm mineral wool	
Extract filter	G4			
Intake filter	G4, F7 (H13 optional)			
Connected air duct diameter [mm]	160			
Weight [kg]	53	54	55	56
Heat recovery efficiency [%]	from 72 up to 87		from 71 up to 87	
Heat exchanger type	rotary			
SEC class	A			

*Sound pressure level: dB(A) figures are average spherical free-field, at 70 % airflow and 50 Pa, for comparative use only.

During the first 2-3 weeks of operation, a slight increase in sound pressure level is possible due to the adaptation of the geometric dimensions of the rotary recuperator seal.

Parameters	KOMFORT Roto EC D2 350	KOMFORT Roto EC D2E350	KOMFORT Roto EC D350	KOMFORT Roto EC DE350
Unit voltage [V/50 (60) Hz]	1~ 230			
Maximum unit power (without a heater) [W]	200		185	
Maximum unit power (with a heater) [W]	-	1600	-	1585
Maximum unit current (without a heater) [A]	1.3		1.3	
Maximum unit current (with a heater) [A]	-	6.9	-	6.9
Maximum air flow [m ³ /h]	400		430	
RPM [min ⁻¹]	3200		3570	
Sound pressure level at 3 m distance [dBA]	33*		31*	
Maximum transported air temperature [°C]	from -25 up to +40			
Casing material	aluzinc			
Insulation	20 mm mineral wool		40 mm mineral wool	
Extract filter	G4			
Intake filter	G4, F7 (H13 optional)			
Connected air duct diameter [mm]	160			
Weight [kg]	78	79	81	82
Heat recovery efficiency [%]	from 73 up to 87		from 72 up to 87	
Heat exchanger type	rotary			
SEC class	A			

*Sound pressure level: dB(A) figures are average spherical free-field, at 70 % airflow and 50 Pa, for comparative use only.

During the first 2-3 weeks of operation, a slight increase in sound pressure level is possible due to the adaptation of the geometric dimensions of the rotary recuperator seal.

Parameters	KOMFORT Roto EC D650	KOMFORT Roto EC DE650
Unit voltage [V/50 (60) Hz]	1~ 230	
Maximum unit power (without a heater) [W]	367	
Maximum unit power (with a heater) [W]	-	3167
Maximum unit current (without a heater) [A]	2.5	
Maximum unit current (with a heater) [A]	-	13.7
Maximum air flow [m ³ /h]	710	
RPM [min ⁻¹]	3600	
Sound pressure level at 3 m distance [dBA]	36*	
Maximum transported air temperature [°C]	from -25 up to +40	
Casing material	aluzinc	
Insulation	40 mm mineral wool	
Extract filter	G4	
Intake filter	G4, F7 (H13 optional)	
Connected air duct diameter [mm]	200	
Weight [kg]	102	104
Heat recovery efficiency [%]	from 80 up to 87	
Heat exchanger type	rotary	
SEC class	A	

*Sound pressure level: dB(A) figures are average spherical free-field, at 70 % airflow and 50 Pa, for comparative use only.

During the first 2-3 weeks of operation, a slight increase in sound pressure level is possible due to the adaptation of the geometric dimensions of the rotary recuperator seal.

DESIGN AND OPERATING PRINCIPLE

The unit has the following operating principle:

Warm stale extract air from the room flows to the unit, where it is filtered. Then the air is moved through the rotary heat exchangers and is exhausted outside with the exhaust fan. Clean cold air from outside is moved to the supply filter. Then filtered air flows through the rotary heat exchanger where it is warmed up to the pre-set temperature value and is moved to the room with the supply fan.

Heat energy of warm extract air is transferred to clean intake fresh air from outside and warms it up.

Heat recovery minimizes losses of electric energy and space heating expenses in cold seasons and cooling expenses in warm seasons. An exhaust kitchen hood may be optionally connected to the unit. The kitchen hood should be equipped with an air valve. The valve closes the exhaust duct when the kitchen hood is switched off.

Right-handed modification (KOMFORT Roto EC D2E350 S21)

(service side view)

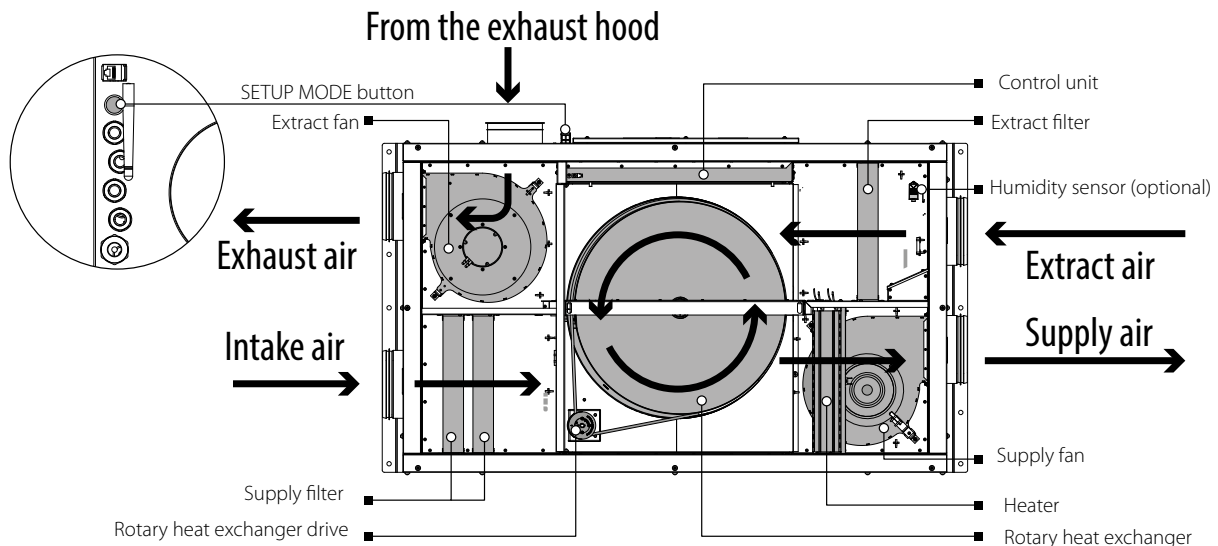

Left-handed modification (KOMFORT Roto EC D2E350 S21)

(service side view)

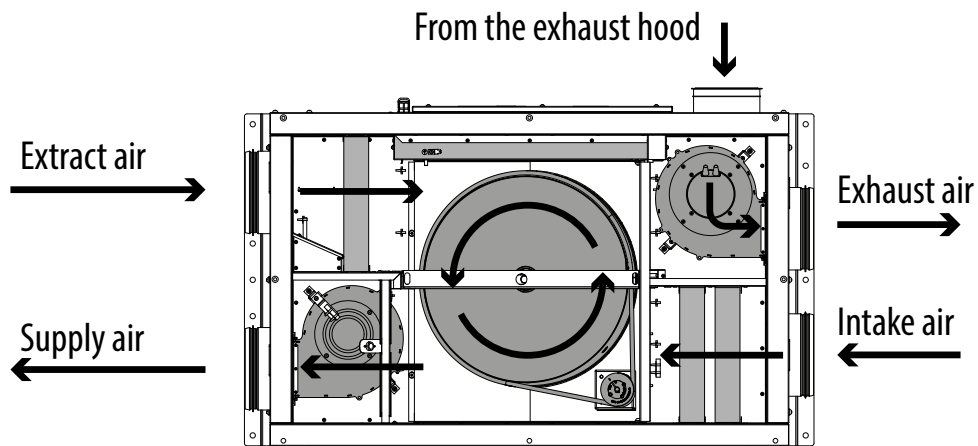

The unit is a framework construction made of rigidly fixed panels.

The panels are made of aluzinc and galvanized sheets, internally filled with a heat- and sound-insulated layer of mineral wool.

The air handling unit is equipped with quick-detachable service panels for filter replacement.

Route power and ground cables through the screwed cable glands to connect those to the terminal block located in the control unit.

The wiring diagram is shown on the control unit side panel.

INSTALLATION AND SET-UP

 **READ THE USER'S MANUAL PRIOR TO MOUNTING THE UNIT.**

 **THE UNIT MUST BE MOUNTED BY A QUALIFIED EXPERT ONLY, PROPERLY TRAINED AND HAVING THE REQUIRED TOOLS AND MATERIALS.**

While mounting the unit provide enough access for maintenance or repair work.
The minimum recommended clearances between the unit and the adjoining walls are given in the figure below.

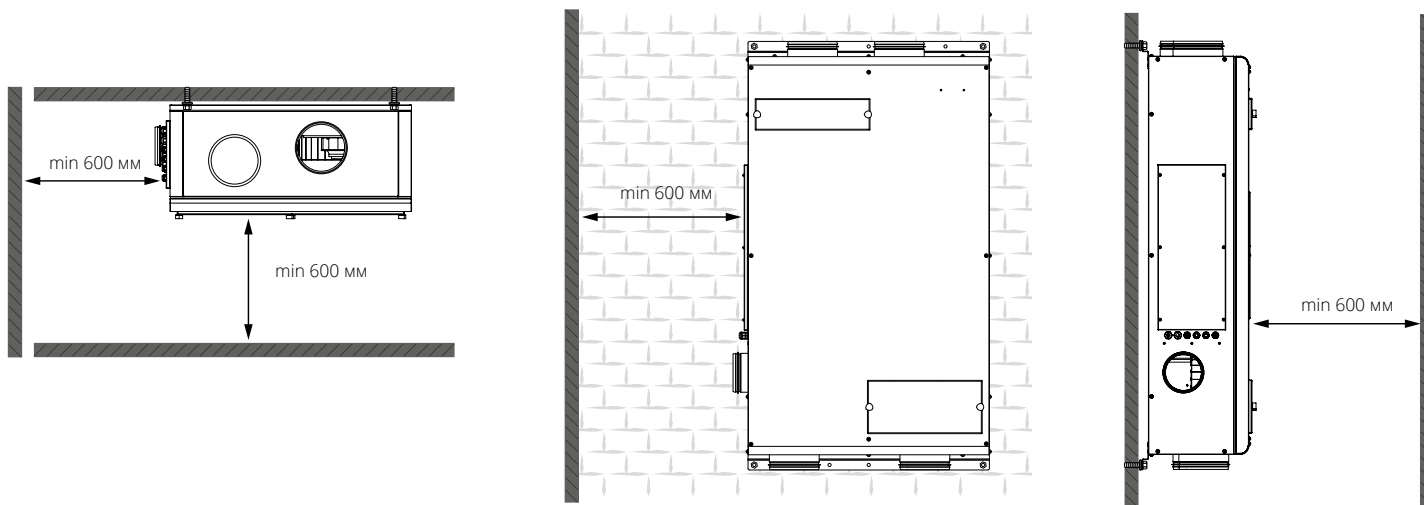

Before starting the unit make sure that the rotary heat exchanger cells are clean and free from damage.
Check the belt tension. The tension force is regulated by the spring on the motor suspension mount.
The unit may be suspended on a threaded rod that is fixed inside a dowel or may be rigidly fixed on a horizontal or vertical plane.

SUSPENDED MOUNTING OF THE UNIT

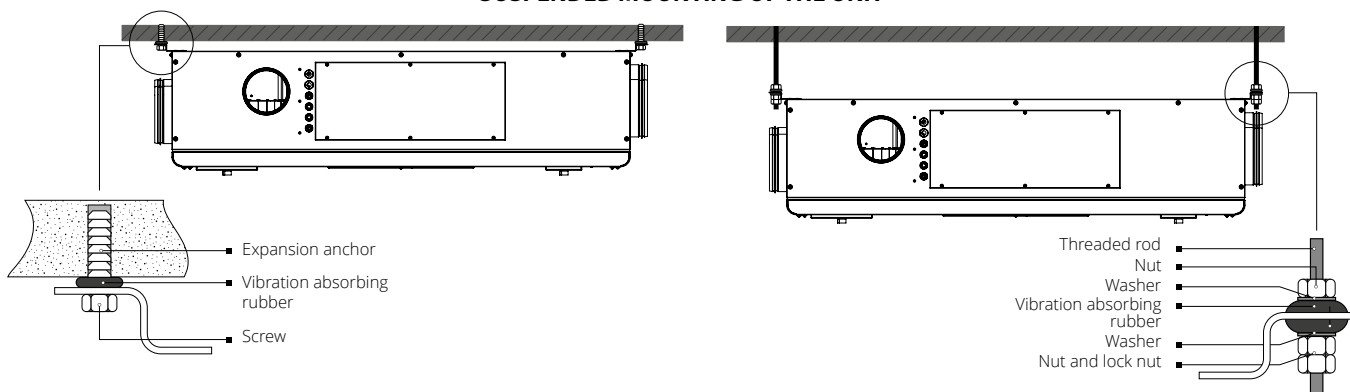

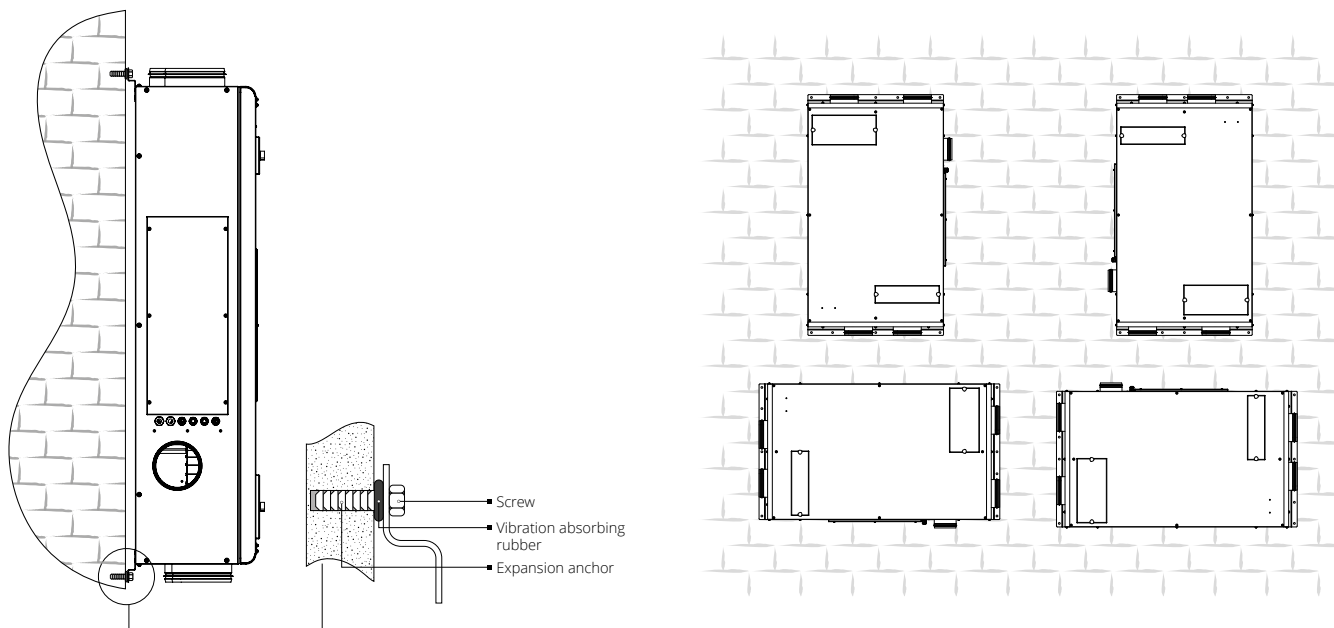
UNIT WALL MOUNTING

To get the best performance of the unit and to minimize turbulence-induced air pressure losses, connect the straight air duct section to the spigots on both sides of the unit while installing.

Minimum straight air duct length:

- equal to 1 air duct diameter on the intake side
- equal to 3 air duct diameters on outlet side

If the air ducts are too short or not connected, protect the unit parts from ingress of foreign objects.

To prevent uncontrollable access to the fan, the spigots may be covered with a protecting grille or other protecting device with mesh width not more than 12.5 mm.

While installing the unit, ensure convenient access for subsequent maintenance and repair. Fasteners for ceiling mounting are not included into delivery set and should be ordered separately. While choosing fasteners consider the material of the mounting surface as well as the weigh of the unit, refer to the "Technical data" section. Fasteners for unit mounting should be selected by the service technician.

HUMIDITY SENSOR MOUNTING

The humidity sensor is not included in the delivery set and should be ordered separately. It must be installed in the exhaust duct upstream of the heat exchanger.

Undo the screws on the service panel and remove it. Screw the humidity sensor to the exhaust air duct wall. Connect the humidity sensor connector to the cable of the control unit (installed by the manufacturer).

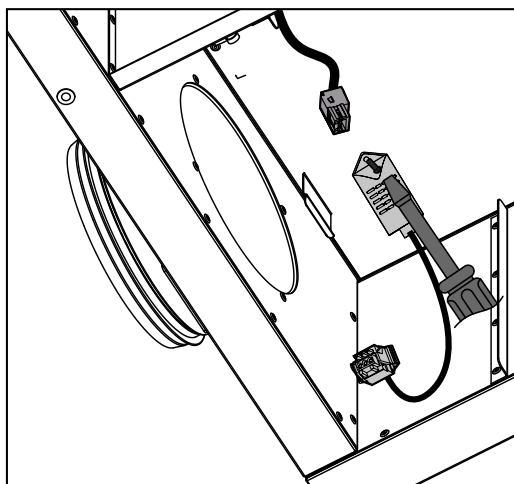

CONNECTION TO POWER MAINS

**POWER OFF THE POWER SUPPLY PRIOR TO ANY OPERATIONS WITH THE UNIT.
THE UNIT MUST BE CONNECTED TO POWER SUPPLY BY A QUALIFIED ELECTRICIAN.
THE RATED ELECTRICAL PARAMETERS OF THE UNIT ARE GIVEN ON THE
MANUFACTURER'S LABEL.**

**ANY TAMPERING WITH THE INTERNAL CONNECTIONS IS PROHIBITED
AND WILL VOID THE WARRANTY.**

- The unit is rated for connection to 230 V/50 (60) Hz power mains according to the wiring diagram.
- The connection must be made using insulated conductors (cables, wires). The actual wire cross section selection must be based on the maximum load current, maximum conductor temperature depending on the wire type, insulation, length and installation method.
- The external power input must be equipped with a QF automatic circuit breaker built into the stationary wiring to open the circuit in the event of overload or short-circuit. The position of the external automatic circuit breaker must ensure free access for quick power-off of the unit. The trip current of the automatic circuit breaker must exceed the maximum current consumption of the unit (refer to the "Technical data" section or on the unit label). The recommended trip current of the circuit breaker is the next current in the standard trip current row following the maximum current of the connected unit. The automatic circuit breaker is not included in the delivery set and can be ordered separately.

EXTERNAL WIRING DIAGRAM FOR THE KOMFORT Roto EC D/D2/DE/D2E250/350/650 S17/S18 UNIT

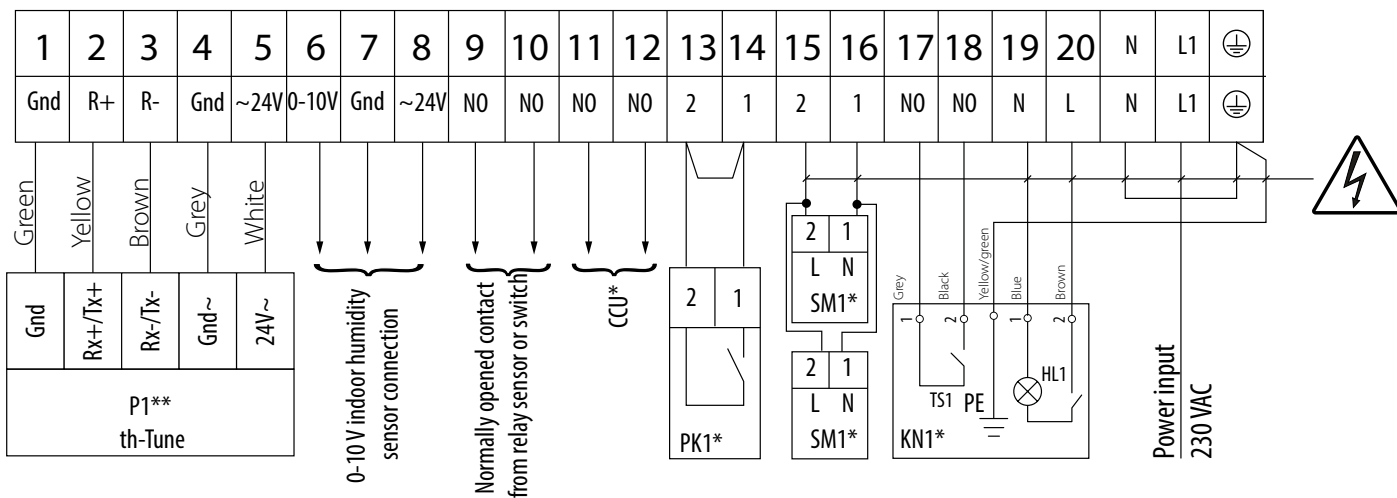

 — **ELECTRIC SHOCK HAZARD!**

Designation	Name	Model	Wire**
SM1*	Supply air damper actuator	LF230	2x0.75 mm ²
SM2*	Exhaust air damper actuator	LF230	2x0.75 mm ²
PK1*	Contact from fire alarm panel	NC	2x0.75 mm ²
CCU*	CCU control	NO	2x0.75 mm ²
P1**	Control panel	th-Tune	2x0.75 mm ²
KH1*	Contact from kitchen hood		

* Devices are not supplied with the unit, are available on separate order.

** The unit can be equipped with a th-Tune control panel

*** Wire cross-section at a cable length of maximum 100 m.

Maximum cable length from the controller to the control panel

Cable type	Distance to power source
Telephone cable	Up to 50 m
AWG24 shielded cable	Up to 200 m

EXTERNAL WIRING DIAGRAM FOR THE KOMFORT Roto EC D/D2/DE/D2E250/350/650 S21 UNIT

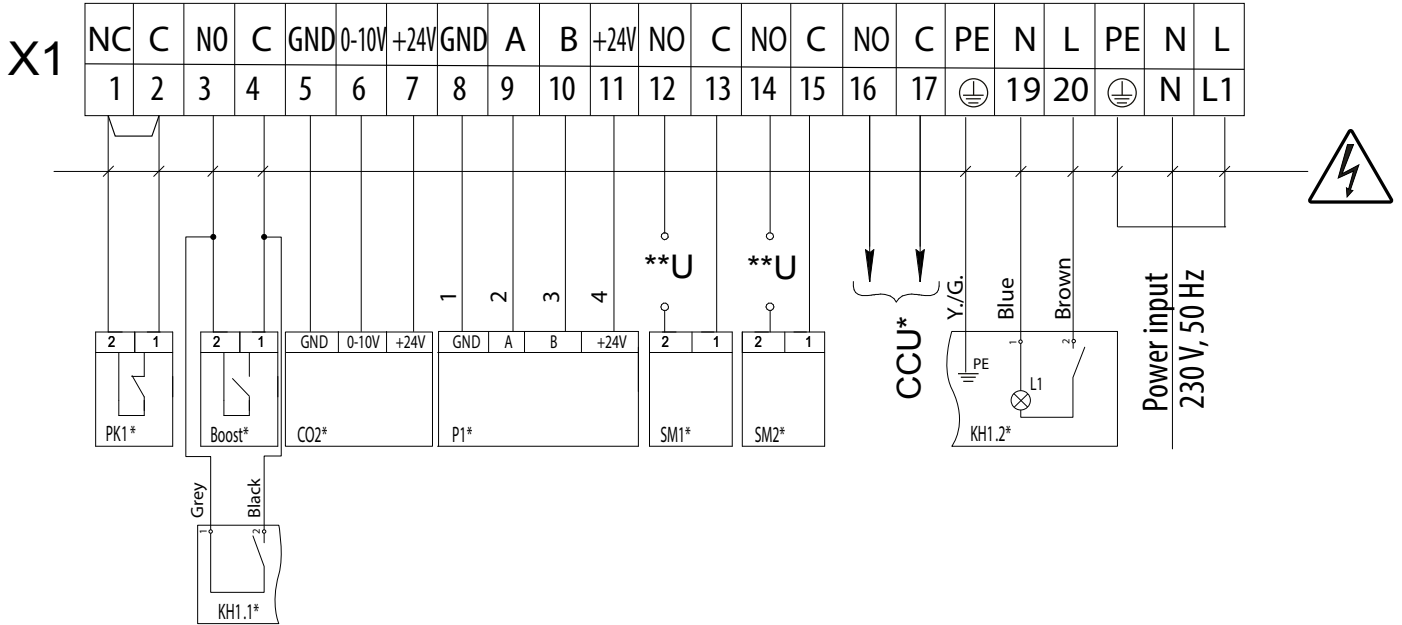

— ELECTRIC SHOCK HAZARD!

Designation	Name	Contact type	Cable type	Note
SM1*	Supply air damper actuator	NO	2 x 0.75 mm ²	3 A, 30 DC/~250 AC
SM2*	Exhaust air damper actuator	NO		3 A, 30DC/~250 AC
PK1*	Contact from fire alarm panel	NC		Remove the jumper
CCU*	CCU control	NO		3 A, 30 DC/~250 AC
P1*	External control panel		4 x 0.5 mm ²	
Boost*	On/Off contacts of the Boost mode	NO	2 x 0.75 mm ²	
CO2*	Outdoor CO ₂ sensor		3 x 0.25 mm ²	
KH1*	Kitchen hood		5 x 0.75 mm ²	

*Is not included in the delivery set.

*The supply voltage U of the SM1, SM2 external dampers is selected depending on the type of dampers.

Output parameters: terminals 12-17 - 3 A, 30 V DC / ~ 250 V AC ("dry contact").

The maximum cable length from external devices to the terminal block should not exceed 100 meters. The recommended cable cross-section is shown in the table.

Access to the terminal block is shown in the figure below.

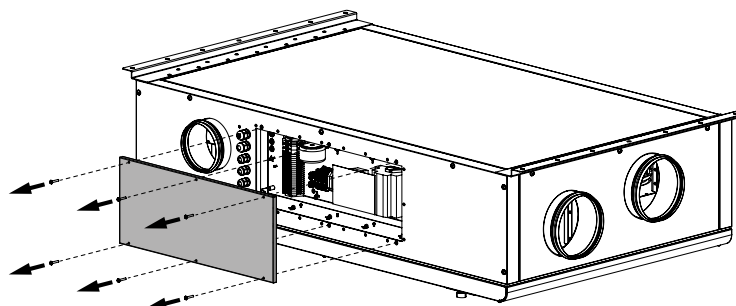

TECHNICAL MAINTENANCE



DISCONNECT THE UNIT FROM POWER SUPPLY BEFORE ANY MAINTENANCE OPERATIONS!
MAKE SURE THE UNIT IS DISCONNECTED FROM POWER MAINS BEFORE REMOVING THE PROTECTION.

Maintenance operations of the unit are required 3-4 times per year. Maintenance includes general cleaning of the unit and the following operations:

1. Filter maintenance.

Dirty filters increase air resistance in the system and reduce supply air volume. The filters require cleaning not less than 3-4 times per year. When 3 000 operating hours have elapsed, the unit controller generates the filter replacement or cleaning alert. Clean or replace the filters and reset the hour meter. Vacuum cleaning is allowed.

After two consecutive cleanings filters must be replaced. For new filters contact the Seller.

Sequence of filter removal:

1. Disconnect the unit from power mains.
2. Unscrew the triangular screws holding the service covers.
3. Remove the service covers.
4. Remove the plugs.
5. Pull the filters to remove.
6. Install the filters in the reverse order.

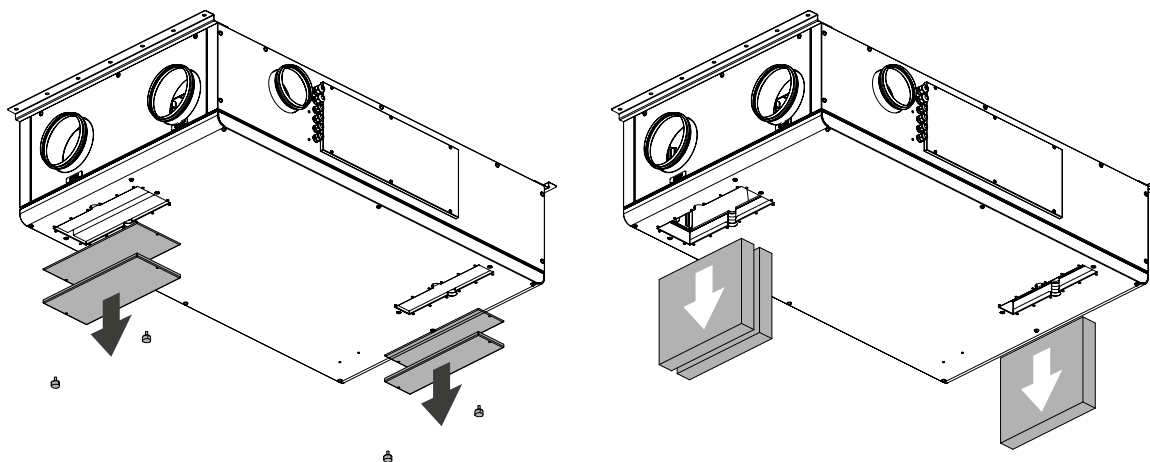

2. Heat exchanger maintenance (once per year).

Some dust may accumulate on the heat exchanger block even in case of regular maintenance of the filters. To maintain the high heat recovery efficiency, regular cleaning is required.

To clean the heat exchanger, remove it from the unit and clean the heat exchanger by using compressed air or a vacuum cleaner.

After cleaning re-install the heat exchanger into the unit. Sequence of heat exchanger removal:

1. Undo the 8 screws and remove the service panel.
2. Clean the heat exchanger with a compressor or a vacuum cleaner.

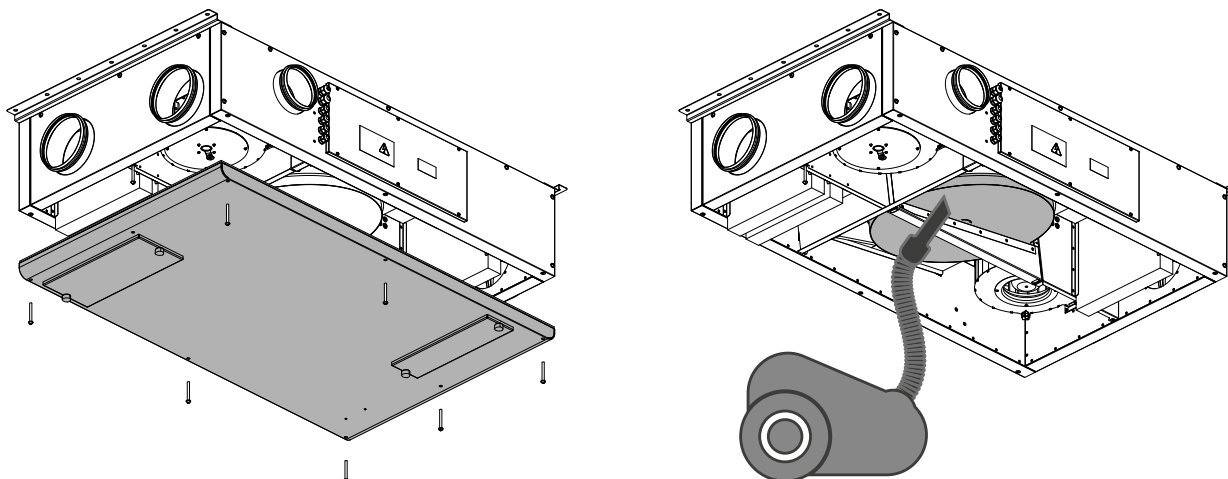

3. Fan maintenance (once per year).

Even in case of regular maintenance of the filters, some dust may accumulate inside the fans and reduce the fan performance and supply air flow. Clean the fans with a soft cloth or brush.

Do not use water, aggressive solvents, or sharp objects as they may damage the impeller.

4. Supply air flow control (twice per year).

The supply duct grille may get clogged with leaves and other objects reducing the unit performance and supply air delivery.

Check the supply grille twice per year and clean it as required.

5. Ductwork system maintenance (once in 5 years).

Even regular fulfilling of all the maintenance operations prescribed above may not completely prevent dirt accumulation in the air ducts, which leads to air pollution and reduces the unit capacity. Duct maintenance means regular cleaning or replacement.

POSSIBLE REASONS AND TROUBLESHOOTING

Problem	Possible reasons	Troubleshooting
The fan(s) do(es) no start.	No power supply.	Make sure the power supply line is connected correctly, otherwise troubleshoot a connection error.
	The motor is jammed, the impeller blades are soiled.	Turn the unit off. Troubleshoot the motor jam and the impeller clogging. Clean the blades. Restart the unit.
	Alarm in the system. System alarms are listed below.	Identify the system failure by entering the active alarms menu and eliminate the alarm. If the system alarm cannot be eliminated by the user, contact the Seller.
Automatic circuit breaker tripping following the unit turning on..	High current consumption caused by a short circuit.	Turn the unit off. Contact the Seller.
Low air flow.	Low set fan speed.	Set higher speed.
	The filters and the fans are clogged, the heat exchanger is clogged.	Clean or replace the filters, clean the fans and the heat exchanger.
	Ventilation system elements (air ducts, diffusers, louver shutters, grilles) are clogged, damaged or closed.	Clean or replace the ventilation system elements, such as air ducts, diffusers, louver shutters, grilles.
Cold supply air.	The extract filter is soiled.	Clean or replace the extract filter.
	The unit operates in Cooling mode.	Check the unit operation settings.
Noise, vibration.	The impeller(s) is soiled.	Clean the impeller(s).
	The fan or casing screw connection is loose.	Tighten the screw connection of the fans or the casing against stop.
	No anti-vibration connectors on air duct pipe flanges.	Install anti-vibration connectors.
SYSTEM ALARMS		
Fire alarm.	Emergency system shutdown on command from the fire alarm board. This alarm interrupts the fan operation.	In case of such alarm follow the emergency instructions and leave the room and the building.
Temperature sensor failure.	Interruption or shortening in the temperature sensor circuit. This alarm interrupts the fan operation.	Contact the Seller.
Control panel failure.	Control panel communication error.	Check the connection of the control panel to the controller. Contact the Seller.
Low supply air temperature.	The supply air temperature is below +14 °C (factory setting).	Clean or replace the extract filter. Check the unit operation settings.
Filter replacement required.	Filter replacement interval expiration.	Clean or replace the filters.

STORAGE AND TRANSPORTATION REGULATIONS

- Store the unit in the manufacturer's original packaging box in a dry closed ventilated premise with temperature range +5... +40 °C and relative humidity up to 70 %.
- Storage environment must not contain aggressive vapors and chemical mixtures provoking corrosion, insulation, and sealing deformation.
- Use suitable hoist machinery for handling and storage operations to prevent possible damage to the unit.
- Follow the handling requirements applicable for the particular type of cargo.
- The unit can be carried in the original packaging by any mode of transport provided proper protection against precipitation and mechanical damage. The unit must be transported only in the working position.
- Avoid sharp blows, scratches, or rough handling during loading and unloading.
- Prior to the initial power-up after transportation at low temperatures, allow the unit to warm up at operating temperature for at least 3-4 hours.

MANUFACTURER'S WARRANTY

The product is in compliance with EU norms and standards on low voltage guidelines and electromagnetic compatibility. We hereby declare that the product complies with the provisions of Electromagnetic Compatibility (EMC) Directive 2014/30/EU of the European Parliament and of the Council, Low Voltage Directive (LVD) 2014/35/EU of the European Parliament and of the Council and CE-marking Council Directive 93/68/EEC. This certificate is issued following test carried out on samples of the product referred to above.

The manufacturer hereby warrants normal operation of the unit for 24 months after the retail sale date provided the user's observance of the transportation, storage, installation, and operation regulations. Should any malfunctions occur in the course of the unit operation through the Manufacturer's fault during the guaranteed period of operation, the user is entitled to get all the faults eliminated by the manufacturer by means of warranty repair at the factory free of charge. The warranty repair includes work specific to elimination of faults in the unit operation to ensure its intended use by the user within the guaranteed period of operation. The faults are eliminated by means of replacement or repair of the unit components or a specific part of such unit component.

The warranty repair does not include:

- routine technical maintenance
- unit installation/dismantling
- unit setup

To benefit from warranty repair, the user must provide the unit, the user's manual with the purchase date stamp, and the payment paperwork certifying the purchase. The unit model must comply with the one stated in the user's manual. Contact the Seller for warranty service.

The manufacturer's warranty does not apply to the following cases:

- User's failure to submit the unit with the entire delivery package as stated in the user's manual including submission with missing component parts previously dismantled by the user.
- Mismatch of the unit model and the brand name with the information stated on the unit packaging and in the user's manual.
- User's failure to ensure timely technical maintenance of the unit.
- Damage to the unit casing and internal components caused by the user.
- Redesign or engineering changes to the unit.
- Replacement and use of any assemblies, parts and components not approved by the manufacturer.
- Unit misuse.
- Violation of the unit installation regulations by the user.
- Violation of the unit control regulations by the user.
- Unit connection to power mains with a voltage different from the one stated in the user's manual.
- Unit breakdown due to voltage surges in power mains.
- Discretionary repair of the unit by the user.
- Unit repair by any persons without the manufacturer's authorization.
- Expiration of the unit warranty period.
- Violation of the unit transportation regulations by the user.
- Violation of the unit storage regulations by the user.
- Wrongful actions against the unit committed by third parties.
- Unit breakdown due to circumstances of insuperable force (fire, flood, earthquake, war, hostilities of any kind, blockades).
- Missing seals if provided by the user's manual.
- Failure to submit the user's manual with the unit purchase date stamp.
- Missing payment paperwork certifying the unit purchase.



FOLLOWING THE REGULATIONS STIPULATED HEREIN WILL ENSURE A LONG AND TROUBLE-FREE OPERATION OF THE UNIT



USER'S WARRANTY CLAIMS SHALL BE SUBJECT TO REVIEW ONLY UPON PRESENTATION OF THE UNIT, THE PAYMENT DOCUMENT AND THE USER'S MANUAL WITH THE PURCHASE DATE STAMP

CERTIFICATE OF ACCEPTANCE

Unit Type	Air handling unit
Model	KOMFORT Roto EC D_____
Serial Number	
Manufacture Date	
Quality Inspector's Stamp	

SELLER INFORMATION

Seller	
Address	
Phone Number	
E-mail	
Purchase Date	
This is to certify acceptance of the complete unit delivery with the user's manual. The warranty terms are acknowledged and accepted.	
Customer's Signature	

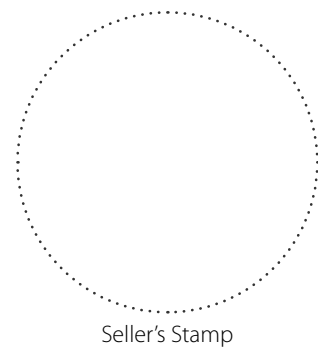

INSTALLATION CERTIFICATE

The KOMFORT Roto EC D_____ unit is installed pursuant to the requirements stated in the present user's manual.	
Company name	
Address	
Phone Number	
Installation Technician's Full Name	
Installation Date:	Signature:
The unit has been installed in accordance with the provisions of all the applicable local and national construction, electrical and technical codes and standards. The unit operates normally as intended by the manufacturer.	
Signature:	

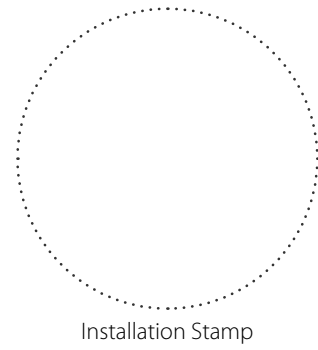

WARRANTY CARD

Unit Type	Air handling unit
Model	KOMFORT Roto EC D_____
Serial Number	
Manufacture Date	
Purchase Date	
Warranty Period	
Seller	



