

# VENTO EXPERT DUO A30-1 Pro

## HEAT RECOVERY SINGLE-ROOM UNITS

### Features

- o Arrangement of efficient energy-saving supply and exhaust single-room ventilation in flats, houses, cottages, social and commercial premises.
- o Reducing heat losses caused by ventilation due to heat recovery.
- o Humidity balance and regulated air exchange create individually controlled microclimate.
- o Coordinated network based on several integrated single-room ventilation units with central control.



**Air flow:**  
up to 30 m<sup>3</sup>/h  
8 l/s



**Heat recovery efficiency:**  
up to 85 %



**Power:**  
from 2.00 W



**Noise level:**  
from 24 dBA



Dear partners! Please note that as of the end of the third quarter of 2020, in order to increase the efficiency of the Vento Expert Duo, the company manufactures products with regenerators divided into two sections.

### Design

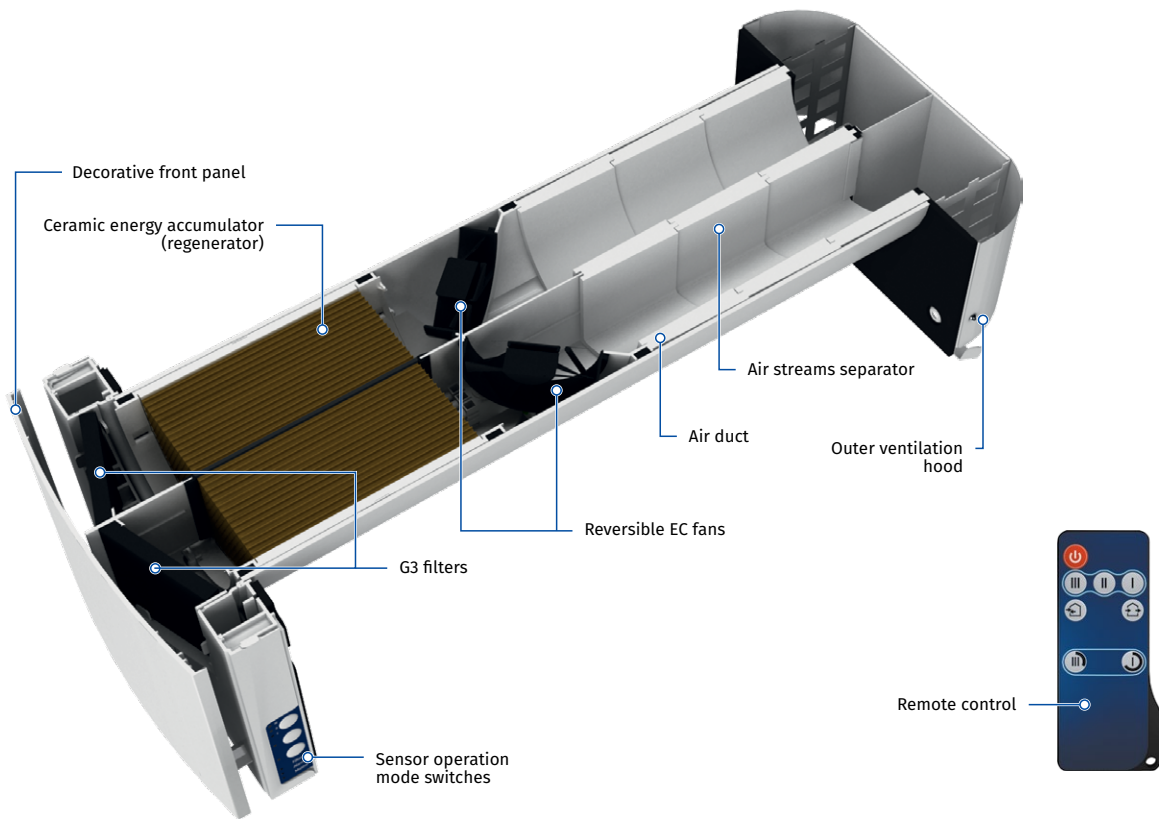

Easy maintenance. Indoor unit is opened by pressing the latches on both sides.

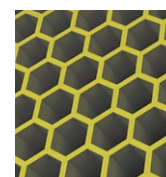

One of the best regeneration efficiency on the market due to innovative hexagonal structure of the heat exchanger cells.

### Designation key

Model	Fans	Air duct	Nominal air flow [m <sup>3</sup> /h]	Unit modification	Control
VENTO Expert	DUO: two fans	A: round air duct	30	1	Pro

# VENTO EXPERT DUO A30-1 Pro

HEAT RECOVERY SINGLE-ROOM UNITS

## Heat and moisture regeneration

### UNIT OPERATING LOGIC IN WINTER PERIOD

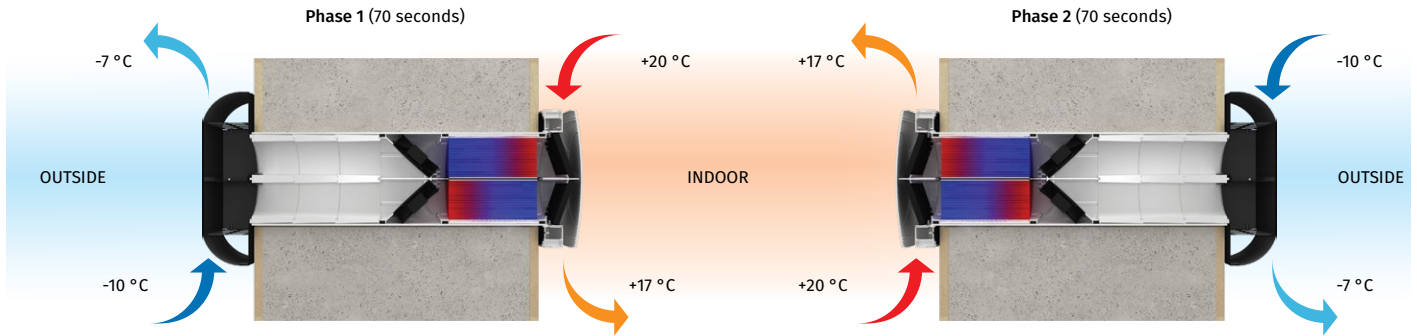

- o To increase the efficiency of the Vento Expert Duo, the regenerator is divided into two parts, which are isolated from one another, thus eliminating the transfer of heat and moisture between them.
- o One of the fans operates in the supply mode: fresh cold intake air from outside flows through the first regenerator, and absorbs accumulated heat and humidity.

- o At the same time, the other fan operates in the exhaust mode: warm stale air is extracted from the room to the outside, and while passing through the other regenerator, gradually heats it up and transfers some of the moisture.
- o After 70 seconds operation the fans change the rotation direction and opposite processes start.

## Control

- o Control of the unit operation mode is performed by means of the sensor control panel located on the unit casing or the remote controller.

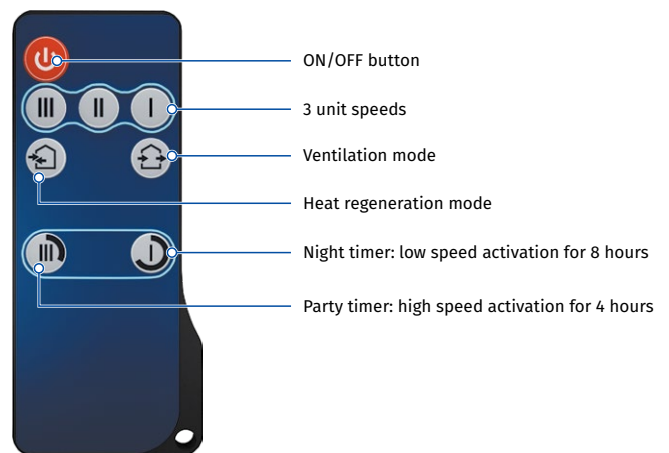
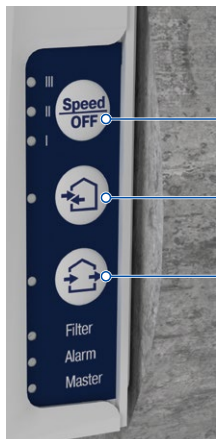

VENTO Expert DUO either can operate as independent unit or can be wired with other units in a house and controlled with a master unit. In this case, only the master unit receives a signal from the remote control.

VENTO Expert DUO is equipped with a humidity sensor for indoor humidity control. If humidity increases above a set point, the unit boosts to the high speed independent of other units in the system.

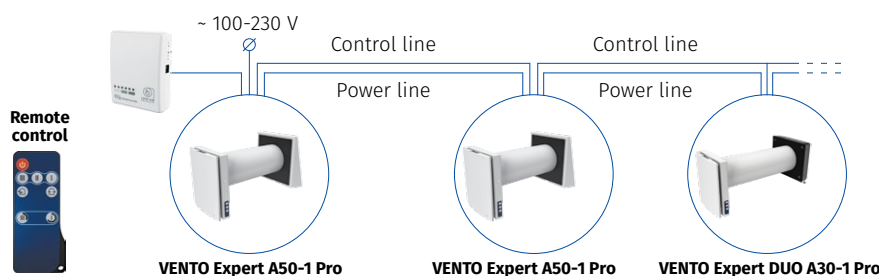

# VENTO EXPERT DUO A30-1 Pro

## HEAT RECOVERY SINGLE-ROOM UNITS

### Mounting

- The unit is designed for through-the-wall installation inside a prepared core hole in an outer wall of the building.
- **VENTO Expert DUO** must be installed in each room with high humidity like kitchen, bathroom to be ventilated while Vento Expert must be installed in each living room to be ventilated.

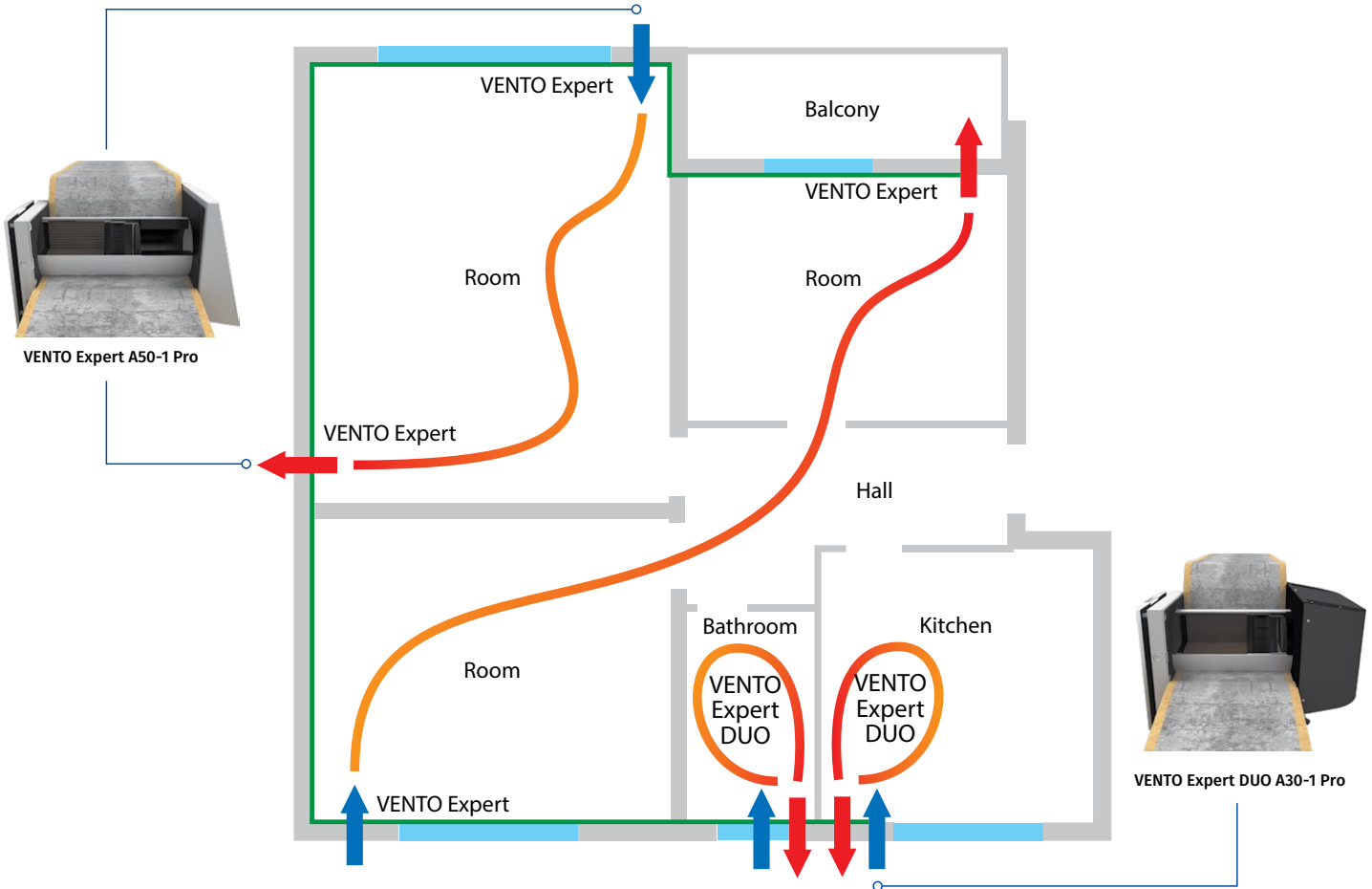

### Overall dimensions [mm]

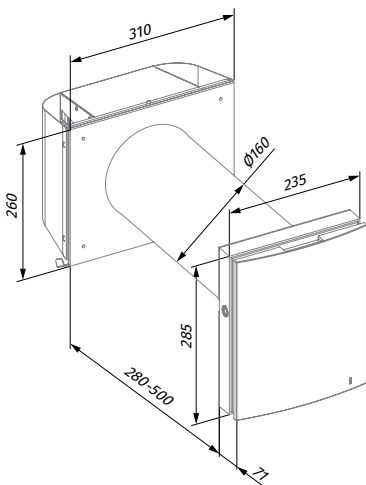

VENTO Expert DUO A30-1 Pro

# VENTO EXPERT DUO A30-1 Pro

HEAT RECOVERY SINGLE-ROOM UNITS

## Technical data

Parameters	VENTO EXPERT DUO A30-1 Pro		
	I	II	III
Speed			
Voltage [V / 50 (60) Hz]		100-240	
Power [W]	2.00	3.70	6.40
Current [A]	0.027	0.043	0.067
RPM [min <sup>-1</sup> ]	1600	2200	2500
Air flow [m <sup>3</sup> /h (l/s)]	10 (3)	20 (6)	30 (8)
Air flow in heat recovery mode [m <sup>3</sup> /h (l/s)]		60 (16)	
Filter		G3	
Transported air temperature [°C]		-15...+50	
Sound pressure level at 1 m [dBA]	33	40	43
Sound pressure level at 3 m [dBA]	24	31	34
Outdoor sound pressure attenuation [dBA] in accordance with DIN EN 20140		42	
Regeneration efficiency [%] in accordance with DIBt LÜ-A 20		up to 85	
SEC Class		A	
Ingress protection rating		IP24	

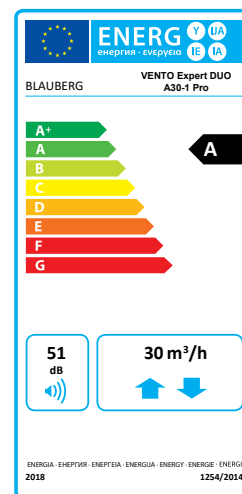

## Accessories

Name		Description
FP Vento Expert DUO A50 G3		G3 filter kit (2 pcs.)
FB Vento Expert A50		Remote control
AH-5 white 160 DUO		Stainless steel ventilation hood, painted white
AH-5 chrome 160 DUO		Brushed stainless steel ventilation hood
AH chrome 160 DUO		Brushed stainless steel ventilation hood
AH white 160 DUO		Aluminum ventilation hood, painted white
PP 160/0.5		Outer ventilation hood for mounting from inside
CD-1		CO <sub>2</sub> sensor with LED indication and on/off button
CD-2		CO <sub>2</sub> sensor
LST Vento Expert DUO		Air stream separator