

# Tubo-M / Tubo-MZ

## Axial inline fans

### Use

- Supply and extract ventilation systems installed in various premises.
- Mounting in ventilation systems with low static pressure requiring high air capacity.
- Compatible with Ø 100 up to 315 mm round air ducts.



**Air flow:**  
up to 1700 m<sup>3</sup>/h  
472 l/s



**Power:**  
from 24 W



**Noise level:**  
from 33 dBA



### Design

- Compact steel casing covered with special polymer coating (**Tubo-M** series) or galvanized steel casing (**Tubo-MZ** series).
- Aluminium impeller.
- The fan is equipped with a power cord and external terminal block for connection to power mains.

### Motor

- Single-phase asynchronous external rotor motor with axial impeller.
- Equipped with ball bearings for longer service life.
- Integrated thermal protection with automatic restart.

### Speed control

- Step speed control with an external auto transformer (available upon separate order).

### Mounting

- Mounting in air duct or directly to the wall in any position with respect to air flow direction in the system.
- Power is supplied to the fan through an external terminal box with sealed electric lead-in.
- Wall or ceiling mounting with fixing brackets supplied as a standard.
- Polymer coated or galvanized steel reducers are provided for connection of the **Tubo-M** fans with Ø 150 up to 250 mm air ducts. The reducers are not included into delivery list and are available upon separate order.
- Tubo-M 315** and **Tubo-MZ 315** with Ø 315 mm air ducts have direct connection.

#### Designation key

Series	Modifications	Connected air duct diameter [mm]
<b>Tubo-M</b>	Z: galvanized steel	<b>150; 200; 250; 315</b>

### Dimensions [mm]

Type	Ø D	B	L	L1	L2	Weight [kg]
<b>Tubo-M / Tubo-MZ 150</b>	162	183	220	40	30	2.08
<b>Tubo-M / Tubo-MZ 200</b>	208	228	220	40	30	2.54
<b>Tubo-M / Tubo-MZ 250</b>	262	283	270	55	30	3.97
<b>Tubo-M / Tubo-MZ 315</b>	315	337	278	55	40	4.84

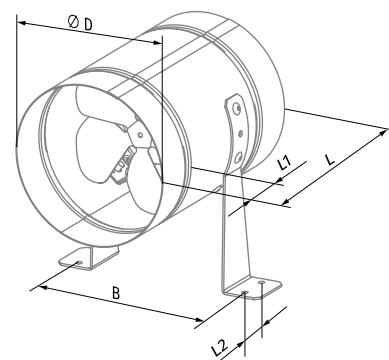

#### Accessories

##### Speed controllers



CDR5E E...TP

### Technical data

Parameters	Tubo-M 150 Tubo-MZ 150		Tubo-M 200 Tubo-MZ 200		Tubo-M 250 Tubo-MZ 250		Tubo-M 315 Tubo-MZ 315	
	1 ~ 220-240		1 ~ 220-240		1 ~ 220-240		1 ~ 220-240	
Voltage [V]	50		60		50		60	
Frequency [Hz]	26		24		33		36	
Power [W]	0.19		0.17		0.23		0.23	
Current [A]	180 (50)		205 (57)		390 (108)		450 (125)	
Maximum air flow [m³/h (l/s)]	1432		1590		1410		1654	
RPM [min⁻¹]	33		33		37		37	
Sound pressure at 3 m [dBA]	42		43		-30 ... +40		-30 ... +40	
Max. transported air temperature [°C]	IPX4		IPX4		IPX4		IPX4	
IP rating	IP44		IP44		IP44		IP44	
Motor IP rating								

#### TUBO-M 150, TUBO-MZ 150

Sound power level, A-weighted	Total	Octave frequency bands [Hz]								LpA 3 m	LpA 1 m
		63	125	250	500	1000	2000	4000	8000		
LWA to environment [dBA]	54	22	35	39	45	49	49	45	39	33	43

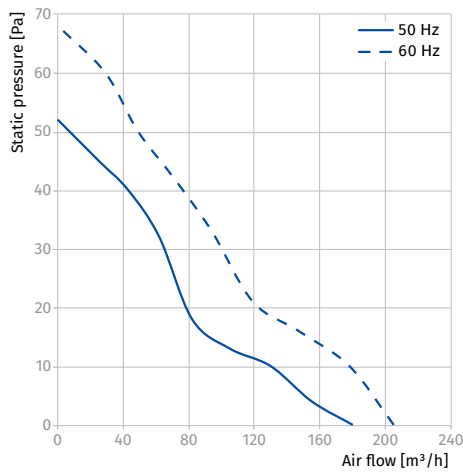

#### TUBO-M 200, TUBO-MZ 200

Sound power level, A-weighted	Total	Octave frequency bands [Hz]								LpA 3 m	LpA 1 m
		63	125	250	500	1000	2000	4000	8000		
LWA to environment [dBA]	53	22	34	38	44	48	48	44	38	32	42

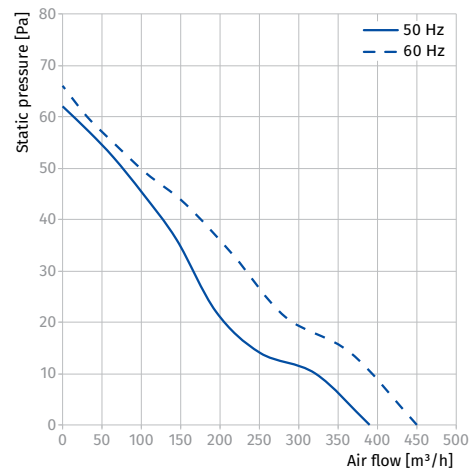

#### TUBO-M 250, TUBO-MZ 250

Sound power level, A-weighted	Total	Octave frequency bands [Hz]								LpA 3 m	LpA 1 m
		63	125	250	500	1000	2000	4000	8000		
LWA to environment [dBA]	58	24	38	42	48	53	53	48	42	37	47

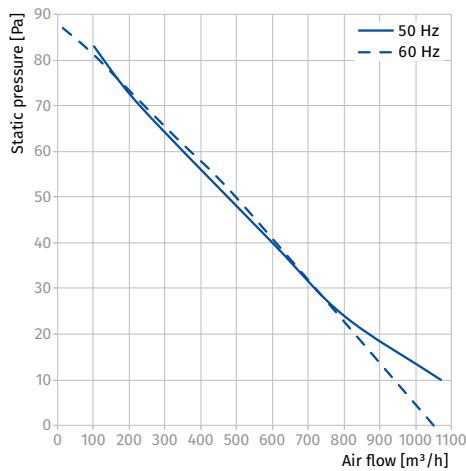

#### TUBO-M 315, TUBO-MZ 315

Sound power level, A-weighted	Total	Octave frequency bands [Hz]								LpA 3 m	LpA 1 m
		63	125	250	500	1000	2000	4000	8000		
LWA to environment [dBA]	62	39	49	44	50	56	49	42	60	42	52

