

# Tower-V EC

## Roof centrifugal fans with EC motor

### Use

- Extract ventilation systems installed in various premises.
- Roof mounting.
- Any roof types or vertical ventilation shafts.
- For arranging energy-saving and controllable ventilation systems.



**Air flow:**  
up to 18270 m<sup>3</sup>/h  
5075 l/s



**Power:**  
from 101 W



**Noise level:**  
from 47 dBA

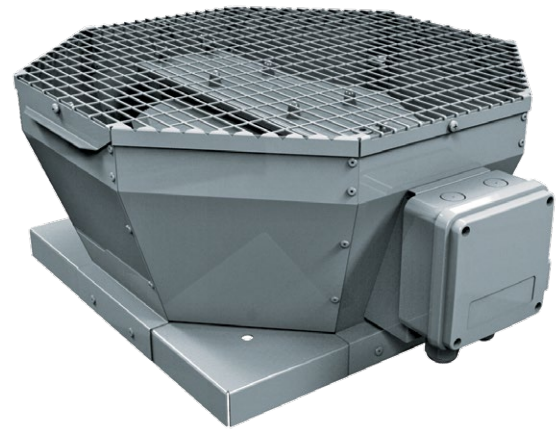

### Design

- The casing is made of steel with a polymer atmospheric resistant coating.
- Vertical air exhaust.
- The fan is equipped with a terminal box for connection to power mains.
- The fan is rated for continuous operation always connected to power mains.
- A connecting plate is provided to facilitate mounting to the roof surface or to the mounting frame.

### Motor

- High-efficient direct current EC motor with external rotor and backward curved blades.
- EC technology meets the up-to-date requirements to energy-saving and controllable ventilation and provides up to 35 % energy saving as compared to asynchronous motors.
- EC motor ensures totally controllable speed range for the fan and has integrated overheating protection with automatic restart.
- EC motor has no friction and wearing parts as capacitor and brushes. Instead a maintenance-free EC controller electronic circuit board is used.
- The impeller is dynamically balanced.
- The fan is compatible with 50 Hz and 60 Hz power mains and the maximum speed does not depend on power mains frequency.

### Operation and speed control

- The fan speed is controlled with a 0–10 V control signal from the following sources:
  - integrated or external speed controller
  - controller with sensors
  - central BMS system.
- The control signal value changes depending on air temperature, pressure, smoke concentration and other parameters.
- During signal value change the fan with EC motor correspondingly changes the rotations speed and delivers required air volume to the ventilation system.
- The computer central building management systems (BMS) enable integration of several EC motors in network and precise individual operation control for each fan.

### Mounting

- Roof mounting directly above a ventilation shaft or an air duct.
- The fan is attached to a square air duct or to the **MRDL/MRIDL** mounting frame (see accessories).
- The counterflange **FDL** mounted on the fan bottom (see accessories) is designed for the fan connection to a round air duct.
- The **KDL** backdraft dampers (see Accessories) are designed to prevent air back drafting when the fan is off.
- The **VDL** flexible connectors (see Accessories) are designed to absorb vibration from the fan to the air duct.
- External terminal box for connection to power mains.

### Designation key

Series	Motor type	Impeller standard size	Casing material
Tower-V	EC: electronically commutated motor	190; 225; 250; 280; 310; 355; 400; 450; 500; 560; 630	_: steel with polymeric coating A: aluminum

### Accessories

Backdraft dampers	Flexible connectors for roof fans	Counterflanges	Mounting frames	Silencers	Backdraft air dampers	Air dampers	Speed controllers
KDL	VDL	FDL	MRDL / MRIDL	SD	VRV	VK / VKA	CDT E/0-10

**Overall dimensions [mm]**

Type	L	L1	H	L2	Weight [kg]
Tower-V EC 190	417	354	166	53	7
Tower-V EC 225	417	355	210	53	7
Tower-V EC 250	481	425	236	53	11
Tower-V EC 280	547	425	274	53	14
Tower-V EC 310	613	477	296	53	20
Tower-V EC 355	738	598	326	53	23
Tower-V EC 400	738	598	371	53	25
Tower-V EC 450	738	668	425	53	44
Tower-V EC 500	859	668	455	53	52
Tower-V EC 560	859	833	478	53	63
Tower-V EC 630	951	890	530	53	80

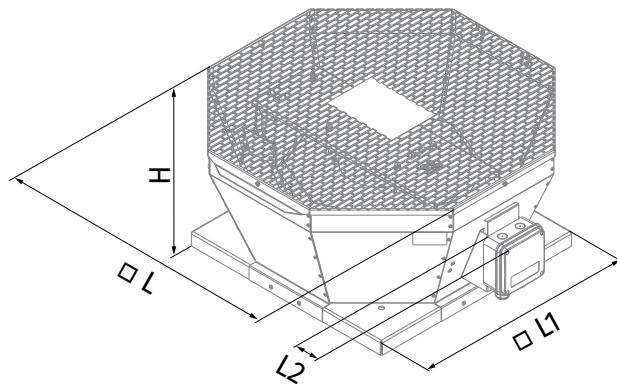

**Technical data**

Parameters	Tower-V EC 190	Tower-V EC 225
Voltage [V]	1 ~ 230	1 ~ 230
Frequency [Hz]	50/60	50/60
Power [W]	102	101
Current [A]	0.77	0.80
Maximum air flow [m <sup>3</sup> /h (l/s)]	670 (186)	1290 (358)
RPM [min <sup>-1</sup> ]	3520	2400
Sound pressure at 3 m [dBA]	52	47
Transported air temperature [°C]	-25...+60	-25...+60
SEC class	B	-
IP rating	IPX4	IPX4
Motor IP rating	IP55	IP55
ErP	2018	2018

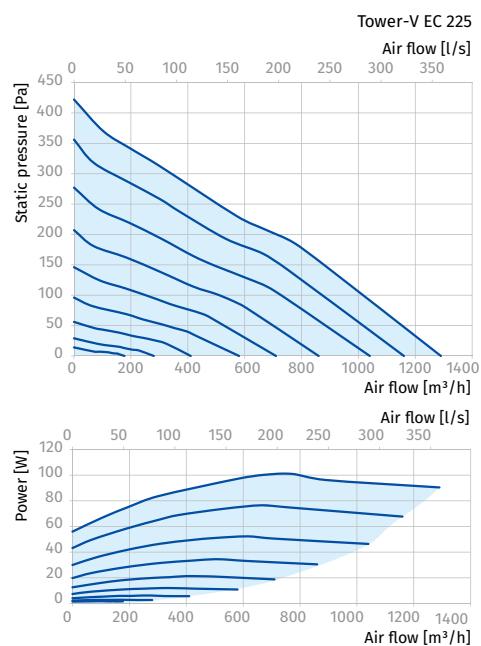
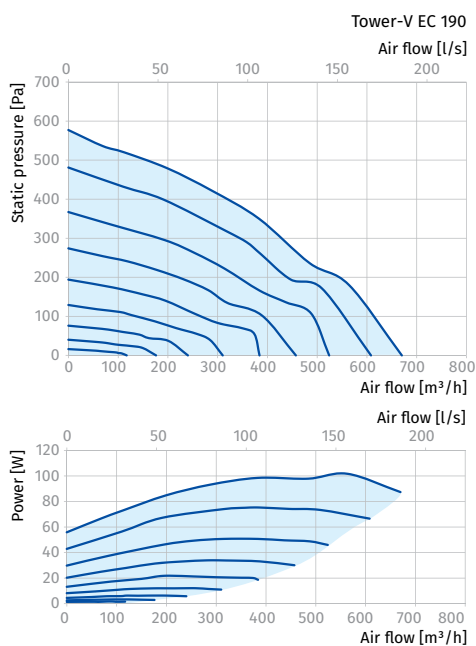

Parameters	Tower-V EC 250	Tower-V EC 280	Tower-V EC 310
Voltage [V]	1 ~ 230	1 ~ 230	1 ~ 230
Frequency [Hz]	50/60	50/60	50/60
Power [W]	161	182	391
Current [A]	1.29	1.34	1.72
Maximum air flow [m³/h (l/s)]	1 470 (408)	2 330 (647)	3 100 (861)
RPM [min <sup>-1</sup> ]	3300	2610	2600
Sound pressure at 3 m [dBA]	54	48	49
Transported air temperature [°C]	-25...+60	-20...+60	-20...+60
SEC class	-	-	-
IP rating	IPX4	IPX4	IPX4
Motor IP rating	IP55	IP44	IP54
ErP	2018	2018	2018

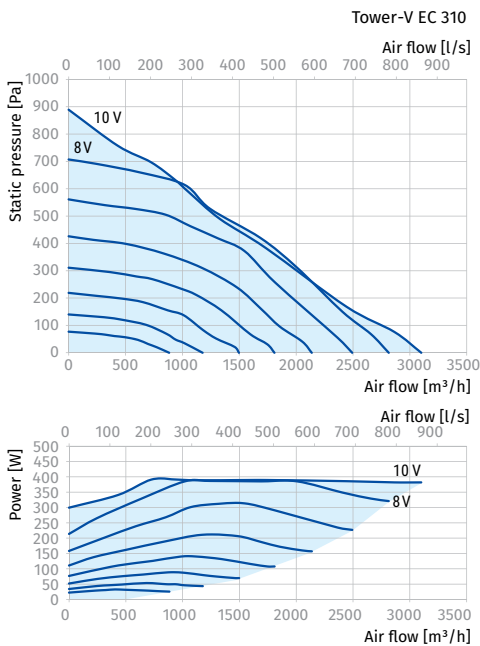
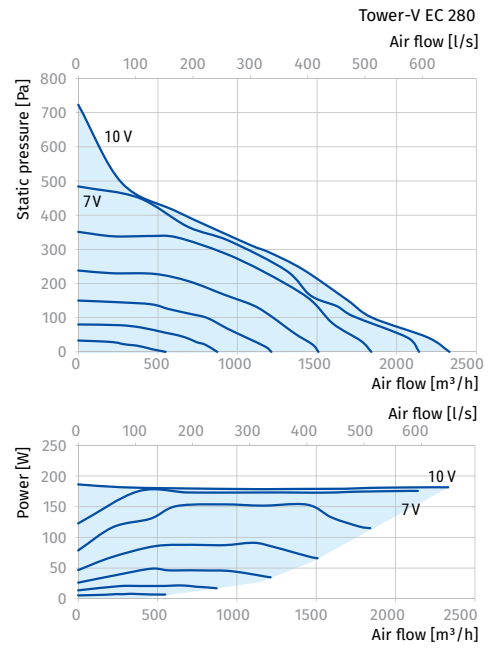
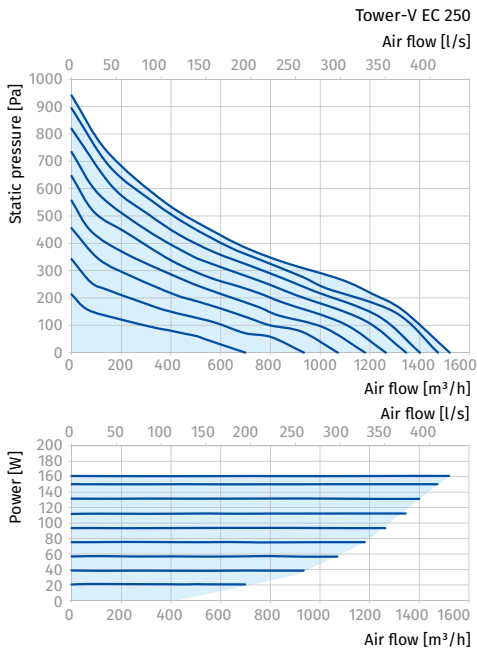

Parameters	Tower-V EC 355	Tower-V EC 400	Tower-V EC 450
Voltage [V]	1 ~ 230	1 ~ 230	3 ~ 400
Frequency [Hz]	50/60	50/60	50/60
Power [W]	669	526	1323
Current [A]	9.36	3.90	3.27
Maximum air flow [m³/h (l/s)]	3 830 (1064)	5 380 (1495)	8 110 (2253)
RPM [min <sup>-1</sup> ]	1550	1450	1560
Sound pressure at 3 m [dBA]	51	58	63
Transported air temperature [°C]	-25...+50	-25...+50	-20...+60
SEC class	-	-	-
IP rating	IPX4	IPX4	IPX4
Motor IP rating	IP54	IP54	IP54
ErP	2018	2018	2018

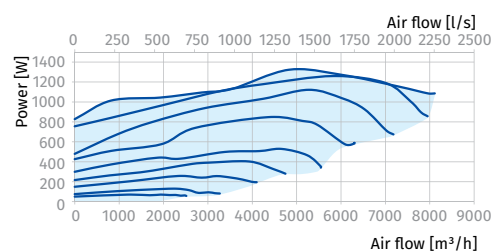
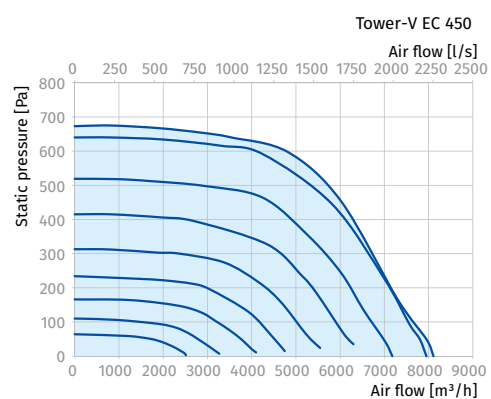
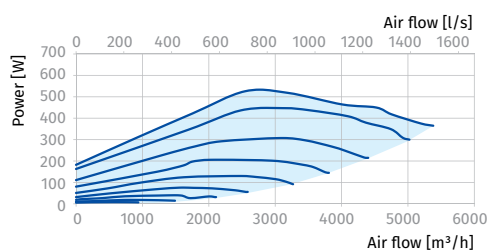
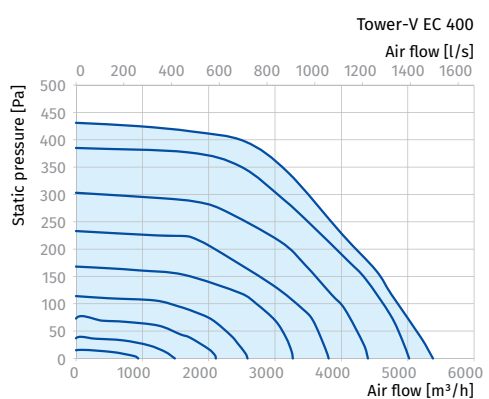
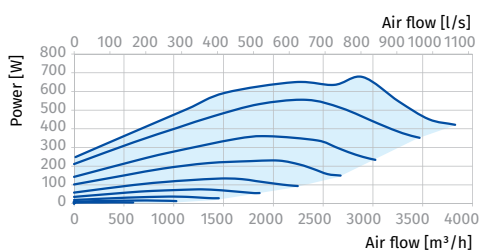
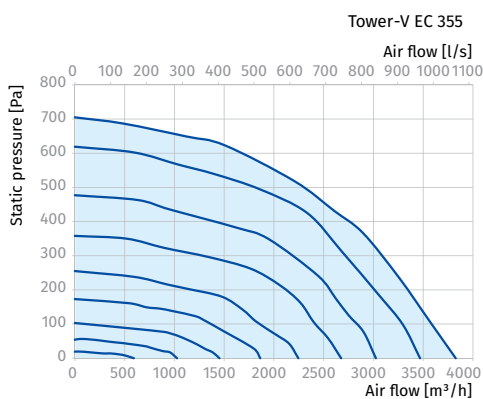

Parameters	Tower-V EC 500	Tower-V EC 560	Tower-V EC 630
Voltage [V]	3 ~ 400	3 ~ 400	3 ~ 400
Frequency [Hz]	50/60	50/60	50/60
Power [W]	1350	2412	2973
Current [A]	2.08	3.83	4.66
Maximum air flow [m³/h (l/s)]	10 900 (3028)	13 640 (3789)	18 270 (5075)
RPM [min <sup>-1</sup> ]	1480	1540	1450
Sound pressure at 3 m [dBA]	67	69	71
Transported air temperature [°C]	-25...+50	-25...+60	-25...+55
SEC class	-	-	-
IP rating	IPX4	IPX4	IPX4
Motor IP rating	IP54	IP54	IP54
ErP	2018	2018	2018

