

# SOLO A35/A50/A60 S4 PRO R V.2

## WALL VENTS

### Features

- Wall ventilator with heat and energy recovery.
- Supply clean fresh air to the premises.
- Control via remote control.
- Remove stale extract air from the premise.
- Clean the air of dust and insects.
- Prevent penetration of excessive humidity and appearance of mould.
- Protect against outdoor noise.
- Heat return and ensuring the balance of humidity in the room thanks to the built-in humidity sensor.
- Reduce the heating costs in winter and air conditioning costs in summer.
- Low energy demand.



**Air flow:**  
up to 60 m<sup>3</sup>/h  
17 l/s



**Heat recovery efficiency:**  
up to 85 %



**Power:** from 1.50 W  
**SFP:** from 0.36 W/l/s



**Noise level:**  
from 21 dBA



### Design

#### FAN

- Air is supplied or extracted by a reversible axial fan with EC motor. Due to EC technology the fan is distinguished with low energy demand. The motor has overheating protection and ball bearings for longer service life.

#### AIR FILTERS

- Two built-in filters with total filter class G3 are used to clean supply and extract air flows. The filters ensure fresh air cleaning of dust and insects and prevent the ventilator parts from soiling. The filters are cleaned either with a vacuum cleaner or flushed with water.

#### ENERGY HEAT EXCHANGER

- The high-technology ceramic energy heat exchanger with recovery efficiency up to 85 % is used for extract air heat energy recovery and supply air heating.

#### HUMIDITY SENSOR

- Helps control the level of humidity in the room. When the sensor is activated, if the humidity in the room exceeds the set level, the ventilator switches to the second (higher) speed. The humidity sensor threshold can be adjusted by turning the potentiometer knob with a special plastic screwdriver. The humidity sensor can be switched on and off using the remote control.

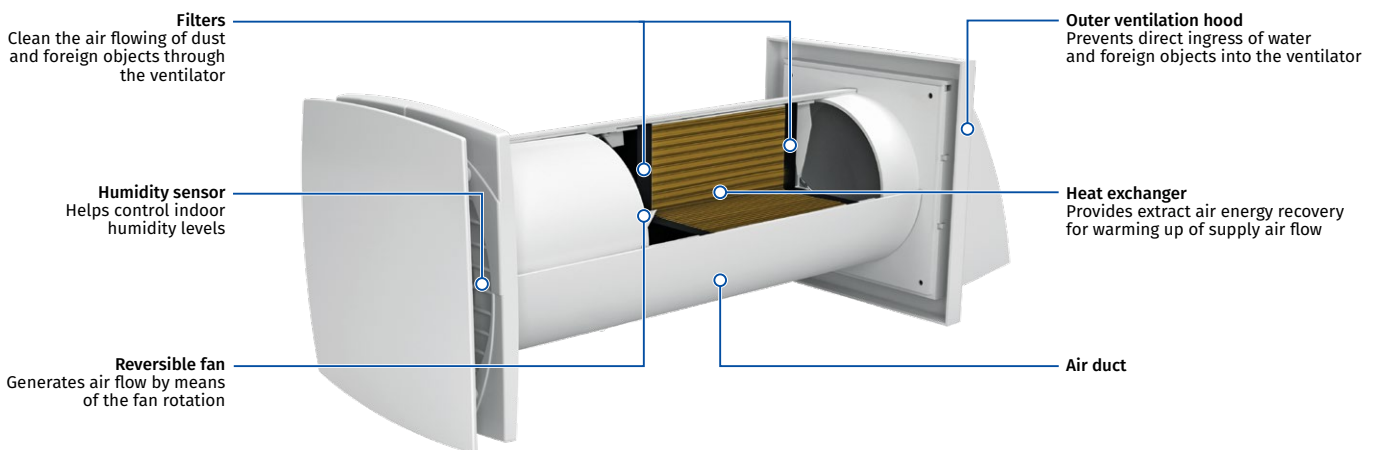

### Operation logic

- Energy is recovered due to reversing operation of the ventilator, which consists of two cycles:
- **CYCLE I.** As warm stale extract air flows through the ceramic heat exchanger, it heats up and moisturizes the heat exchanger. In 60 seconds as the ceramic heat exchanger gets warmed the ventilator automatically switches to Air Supply mode.
- **CYCLE II.** Fresh, cold intake air from outside flows through the ceramic heat exchanger, absorbs accumulated moisture and is heated to the room temperature. In 60 seconds as the heat exchanger gets cooled down, the ventilator switches to Air Extract mode and the cycle is renewed.
- The Air Supply and the Air Extract modes are switched every 60 seconds.

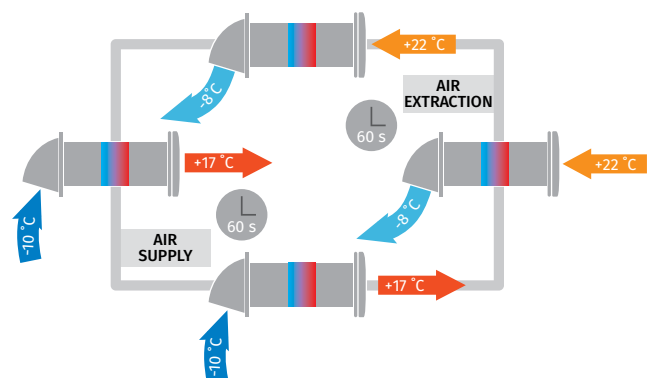

# SOLO A35/A50/A60 S4 PRO R V.2

WALL VENTS

## Control

The humidity sensor and speed are controlled by the remote control.

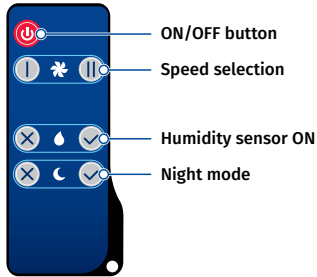

## Overall dimensions [mm]

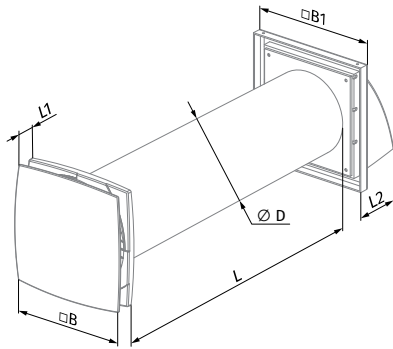

Model	Ø D	B	B1	L	L1	L2
Solo A35 S4 Pro R V.2	106	150	153	305-380	35	69
Solo A50 S4 Pro R V.2	131	175	186	305-380	35	86
Solo A60 S4 Pro R V.2	156	205	186	305-380	35	86

## Mounting example



## Technical data

Parameters	Solo A35 S4 Pro R V.2		Solo A50 S4 Pro R V.2		Solo A60 S4 Pro R V.2	
	I	II	I	II	I	II
Speed						
Voltage [V / 50 (60) Hz]	220-240					
Power [W]	1.50	2.30	0.70	2.30	1.10	3.20
Current [A]	0.046	0.047	0.020	0.034	0.021	0.042
Air flow in ventilation mode [m³/h (l/s)]	30 (8)	46 (13)	25 (7)	50 (14)	35 (10)	60 (17)
SFP [W/l/s]	0.36	0.36	0.20	0.33	0.23	0.38
Sound pressure level at 3 m distance [dBA]	21	26	16	29	27	29
Transported air temperature [°C]	-15...+40					
Energy recovery efficiency [%]	up to 85					
Regenerator type	Ceramic					
SEC class	A					
Ingress protection rating	IP24					



BLAUBERG Solo A35 S4 Pro R V.2

Energy efficiency class: A

Sound power level: 41 dB

Air flow: 23 m³/h

ENERGIA - ΕΝΕΡΓΙΑ - ENERGIJA - ENERGIJA - ENERGY - ENERGIE - ENERGI 2022 1254/2014

BLAUBERG Solo A50 S4 Pro R V.2

Energy efficiency class: A

Sound power level: 36 dB

Air flow: 25 m³/h

ENERGIA - ΕΝΕΡΓΙΑ - ENERGIJA - ENERGIJA - ENERGY - ENERGIE - ENERGI 2022 1254/2014

BLAUBERG Solo A60 S4 Pro R V.2

Energy efficiency class: A

Sound power level: 47 dB

Air flow: 30 m³/h

ENERGIA - ΕΝΕΡΓΙΑ - ENERGIJA - ENERGIJA - ENERGY - ENERGIE - ENERGI 2022 1254/2014