

KWT

Plate heat exchangers for rectangular ducts

Use

- KWT plate heat exchanger with X-shaped air passage designed for exhaust air heat recovery in conditioning and ventilating systems.
- The heat exchangers are connected directly to the rectangular ducts both with parallel and perpendicular or diagonal ducting at 45°.
- Various connection modification are possible due to bend fittings which shall be ordered in the required quantity.
- The transported air shall not contain solid, fibrous, aggressive and explosive impurities.



Design

- The heat exchanger casing is made of galvanized steel. The surface of the heat exchanger consists of thin aluminium plates for efficient heat exchange.
- Some condensate quantity which can be generated at exhaust surface can be removed at the bottom removable panel.
- KWT heat exchangers equipment list includes connecting pipe on the bottom panel for condensate removing.

Accessory

BH BEND

- Designed for easy mounting of the heat exchanger in any modifications of the air duct.



SB C4 SUMMER BLOCK

- For the summer period the heat exchanger can be replaced with the summer block SB C4 which performs no heat recovery but reduces pressure loss by 10 %. It is applied in systems without by-pass at the inlet and in systems with no cooling.

Overall dimensions [mm]

Model	B	B1	B2	H	H1	H2	H3	L	Weight [kg]
KWT 40x20	400	420	440	200	220	240	275	530	17.1
KWT 50x25	500	520	540	250	270	290	325	630	22.6
KWT 50x30	500	520	540	300	320	340	375	630	24.2
KWT 60x30	600	620	640	300	320	340	375	730	31.0
KWT 60x35	600	620	640	350	370	390	425	730	33.4
KWT 70x40	700	720	740	400	420	440	475	830	47.8
KWT 80x50	800	820	840	500	520	540	575	930	61.1
KWT 90x50	900	920	940	500	520	540	575	1130	78.8
KWT 100x50	1000	1020	1040	500	520	540	575	1130	78.3

Model	B	B1	B2	H	H1	H2	Weight [kg]
BH 40x20	400	420	440	200	220	240	2.2
BH 50x25	500	520	540	250	270	290	3.3
BH 50x30	500	520	540	300	320	340	3.5
BH 60x30	600	620	640	300	320	340	4.5
BH 60x35	600	620	640	350	370	390	4.7
BH 70x40	700	720	740	400	420	440	5.9
BH 80x50	800	820	840	500	520	540	7.5
BH 90x50	900	920	940	500	520	540	8.7
BH 100x50	1000	1020	1040	500	520	540	10.3

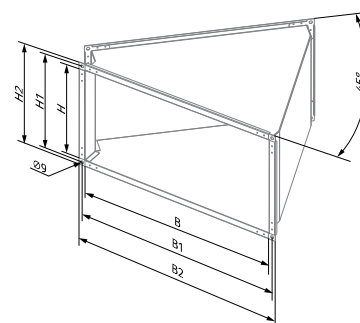
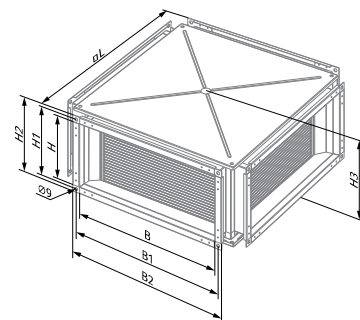

Technical data

- Heat recovery efficiency and air resistance in the air duct are the basic factors that determine the heat exchanger performance.

The thermal efficiency is calculated as following:

$$\eta = \frac{t_s - t_i}{t_e - t_i}$$

- t_s – supply air temperature after heat recuperation
- t_i – intake air temperature before heat recuperation
- t_e – extract air temperature before heat recuperation

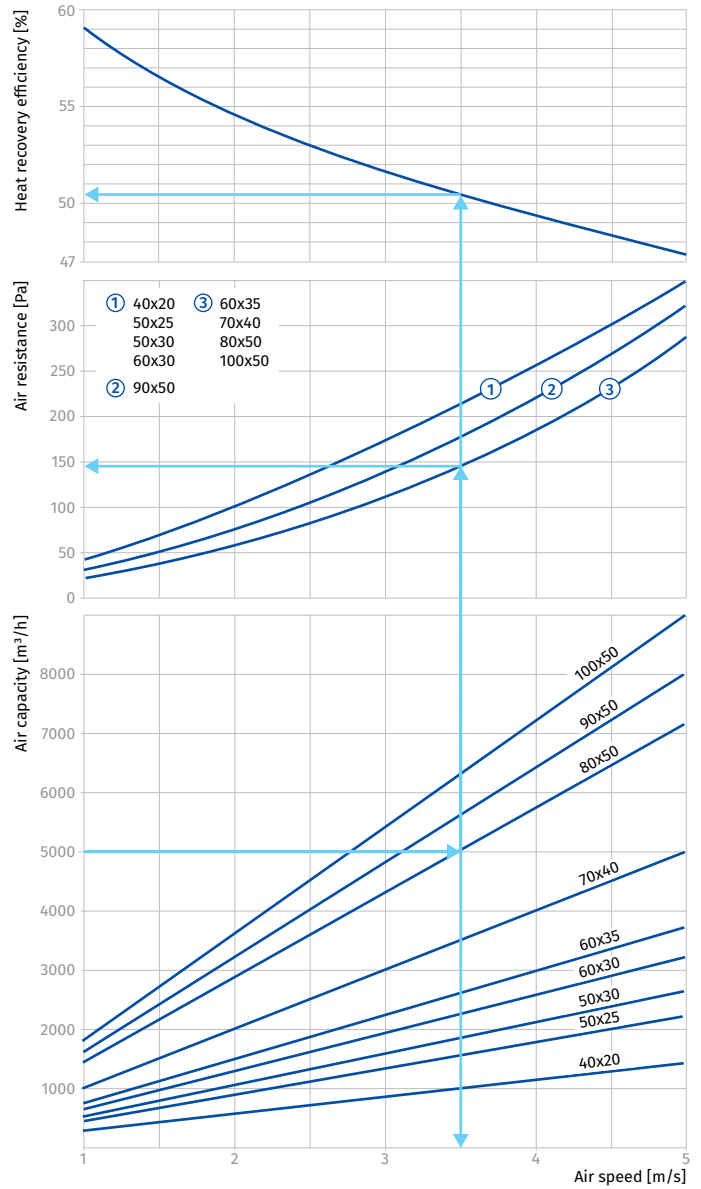

Possible layout arrangements of KWT heat exchanger and BH bends:

