

# KOMFORT Roto EC LE/LW

Air handling units with rotary heat exchanger

## Features

- Air handling units for efficient supply and exhaust ventilation in flats, houses, cottages and other buildings.
- Used to create controlled energy-saving ventilation systems.
- The heat recovery technology is used to minimize ventilation heat losses.
- Control of air exchange for creating comfortable indoor microclimate.
- Compatible with round Ø 160, 250 or 315 mm air ducts. **KOMFORT Roto EC LE/LW 2000** are designed for connection to 500x300 mm rectangular air ducts.



**Air flow:**  
up to 2250 m<sup>3</sup>/h  
625 l/s



**Heat recovery efficiency:**  
up to 95 %



## Design

- **KOMFORT Roto EC LE** – model with electric heater.
- **KOMFORT Roto EC LW** – model with water heater.
- The casing is made of double-skinned aluzinc panels, internally filled with 20–25 mm mineral wool layer for heat- and sound-insulation.
- The casing has mounting brackets with anti-vibration rubber mounts for easy installation.
- The spigots are located at the sides of the unit and are equipped with rubber seals for airtight connection to the air ducts.
- The hinged side panels ensure easy access to the internals for service works including cleaning, filter replacement, etc.

## Air filtration

- The built-in G4 supply filter and G4 extract filter provide air filtration.

## Fans

- The unit is equipped with high-efficient external rotor EC motors and centrifugal impellers with backward curved blades.
- EC motors have the best power consumption to air flow ratio and meet the latest demands concerning energy saving and high-efficient ventilation.
- EC motors are featured with high performance, low noise level and totally controllable speed range.
- The impellers are dynamically balanced.

## Mounting

- The unit can be installed on the floor, suspended to the ceiling or fixed to the wall by means of mounting brackets.
- The correct mounted unit must provide condensate collecting and drainage and free access to the hinged side panel for servicing and filter replacement.
- Access on the left side.

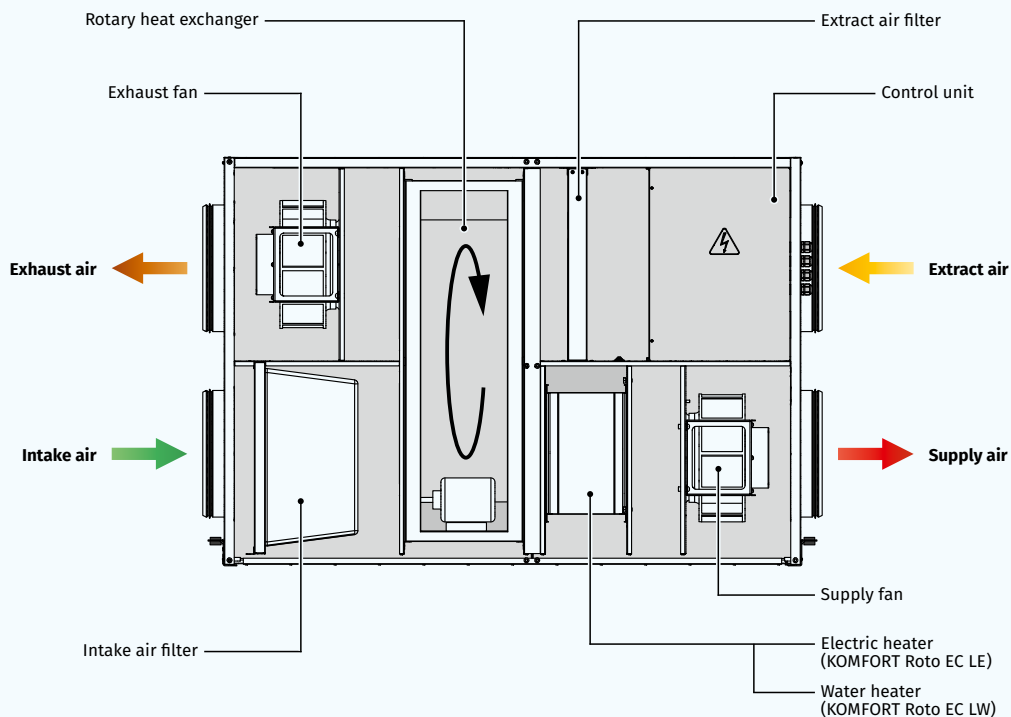

AIR HANDLING UNITS WITH ROTARY HEAT EXCHANGER

### Heat recovery

- The unit has a high-efficient rotary aluminium heat exchanger.
- The rotary regenerator is a short, rotating cylinder, filled with corrugated aluminium sheet layers. The air streams flow through them.
- The band layers of the heat regenerator first come in contact with the supply and then with extract air flows.
- Therefore the band is alternatively warmed up and cooled down and the extract air heat and humidity are transferred to the cold intake air. This way heat recovery reduces heat losses in the cold season and reduces operation load for air conditioner in the warm season.
- The advantages of the rotary regenerator as compared to the plate heat exchangers include no condensate generation, maintaining comfort air humidity and high freeze resistance.

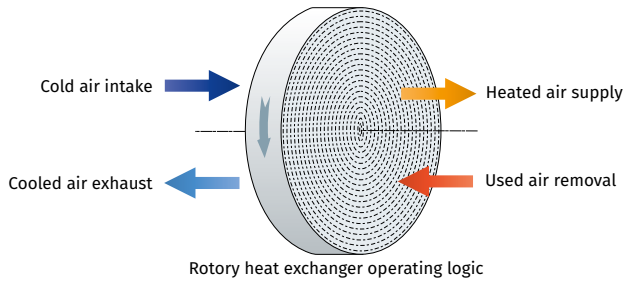

- For overheating protection the electro heater is equipped with two built-in thermal switches: with +60 °C operating temperature, automatic restart, and with +90 °C operating temperature, manual restart.
- **KOMFORT Roto EC LW** are equipped with a water (glycol) heater for operation at low outside temperatures.
- Smooth water heater control ensures automatic maintenance of supply air temperature.
- The air temperature sensor downstream of the heater and the return water temperature sensor are used for freezing protection of the water heater.
- Water heaters are designed for operation with maximum operating pressure of 1 MPa (10 bar) and maximum heat medium operating temperature +95 °C.
- The spigots of water heater are located on service panel side.

### Control and automation

- **KOMFORT Roto EC LE S17** and **KOMFORT Roto EC LW S17** are equipped with the th-Tune control panel.
- **KOMFORT Roto EC LE S18** and **KOMFORT Roto EC LW S18** are equipped with the pGD1 control panel.
- **Automation functions:**
  - Fan speed selection: low, high or medium.
  - Speed setting from 0 to 100 % for supply and exhaust fans separately
  - Filter maintenance indication
  - Alarm indication
  - Timer-based operation of the unit
  - Week-scheduled operation of the unit
  - Control and regulation of supply air temperature
  - CCU controlling
  - Air damper actuator controlling



### Heater

- The integrated heater is activated to warm up supply air flow if set indoor air temperature may not be reached by means of heat recovery only.
- **KOMFORT Roto EC LE** are equipped with an electric heater for operation at low outside temperatures.
  - Smooth electric heater output control ensures automatic maintenance of supply air temperature.

### Designation key

Series	Unit type	Motor type	Spigot modification	Heater type	Rated air flow [m³/h]	Heater parameters	Control
KOMFORT	<b>Roto:</b> rotary heat exchanger	<b>EC:</b> electronically commutated motor	<b>L:</b> horizontal spigot orientation	<b>E:</b> electric heater <b>W:</b> water heater	<b>400; 700; 900; 1200; - 1500; 2000</b>	<b>2; 3.3; ...:</b> heater power [kW] (electric heater) <b>2:</b> heater rows (water heater)	<b>S17:</b> thTune control panel <b>S18:</b> pGD1 control panel

### Overall dimensions [mm]

Model	D	B	B1	H	L	X	Y
KOMFORT Roto EC LE/LW 400	159	648	440	670	1050	-	-
KOMFORT Roto EC LE/LW 700	249	745	580	700	1210	-	-
KOMFORT Roto EC LE/LW 1000	249	745	580	700	1210	-	-
KOMFORT Roto EC LE/LW 1200	314	745	460	880	1335	-	-
KOMFORT Roto EC LE/LW 1500	314	855	560	1010	1430	-	-
KOMFORT Roto EC LE/LW 2000	-	875	630	1010	1485	500	300

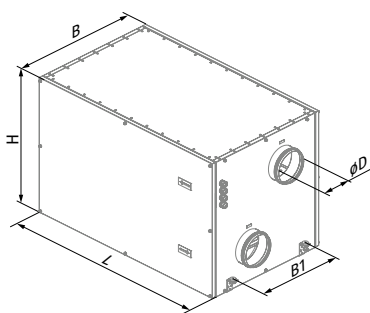

KOMFORT Roto EC LE/LW 400 / Roto EC LE/LW 700 / Roto EC LE/LW 1000

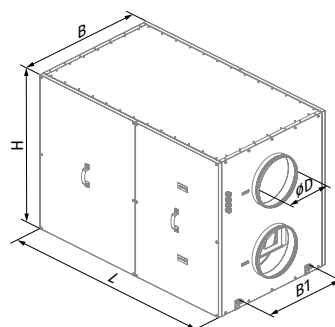

KOMFORT Roto EC LE/LW 1200 / Roto EC LE/LW 1500

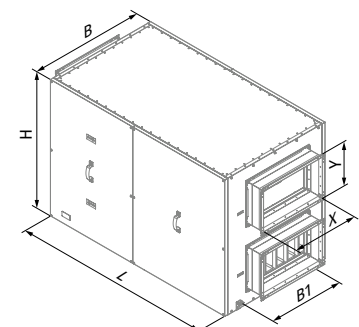

KOMFORT Roto EC LE/LW 2000

**Technical data**

Parameters	KOMFORT Roto EC LE 400-2 S17/S18	KOMFORT Roto EC LE 700-3.3 S17/S18	KOMFORT Roto EC LE 1000-4.5 S17/S18	KOMFORT Roto EC LE 1200-6 S17/S18	KOMFORT Roto EC LE 1500-9 S17/S18	KOMFORT Roto EC LE 2000-12 S17/S18
Voltage [V / 50 (60) Hz]	1 ~ 230	1 ~ 230	3 ~ 400	3 ~ 400	3 ~ 400	3 ~ 400
Motor max. power [W]	2 items x 100	2 items x 105	2 items x 135	2 items x 208	2 items x 222	2 items x 448
Electric heater power [W]	2000	3300	4500	6000	9000	12000
Max. power with electric heater [W]	2290	3615	4940	6570	9750	13070
Max. current with electric heater [A]	9.9	15.8	7.2	9.5	14.1	22.4
Maximum air flow [m <sup>3</sup> /h (l/s)]	400 (111)	700 (194)	900 (250)	1200 (333)	1500 (417)	2250 (625)
RPM [min <sup>-1</sup> ]	up to 3100	up to 2600	up to 2600	up to 1930	up to 2000	up to 3000
Sound pressure level at 3 m [dBA]	45	52	58	60	62	64
Transported air temperature [°C]	-25...+40	-25...+40	-25...+40	-25...+40	-25...+40	-25...+40
Casing material	aluzinc	aluzinc	aluzinc	aluzinc	aluzinc	aluzinc
Insulation	20 mm mineral wool	20 mm mineral wool	20 mm mineral wool	20 mm mineral wool	25 mm mineral wool	25 mm mineral wool
Extract filter	G4	G4	G4	G4	G4	G4
Supply filter	G4	G4	G4	G4	G4	G4
Connected air duct diameter [mm]	160	250	250	315	315	500x300
Weight [kg]	112	128	130	165	175	198
Heat recovery efficiency [%]	80-95	76-95	72-95	73-95	72-95	68-93
Heat exchanger type	rotary	rotary	rotary	rotary	rotary	rotary
Heat exchanger material	aluminium	aluminium	aluminium	aluminium	aluminium	aluminium
SEC class	A	A	A	NRVU*	NRVU*	NRVU*
ErP	2016, 2018	2016, 2018	2016, 2018	2016, 2018	2016, 2018	2016, 2018

\*Nonresidential Ventilation Unit.

AIR HANDLING UNITS WITH ROTARY HEAT EXCHANGER

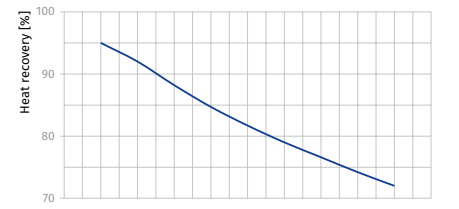
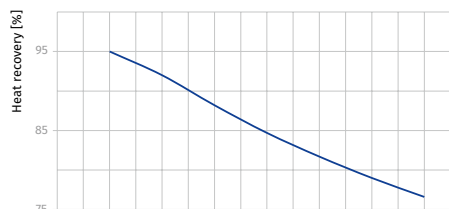
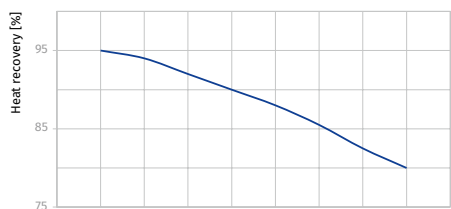
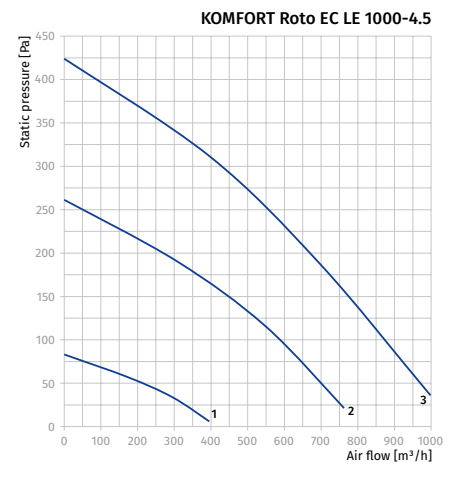
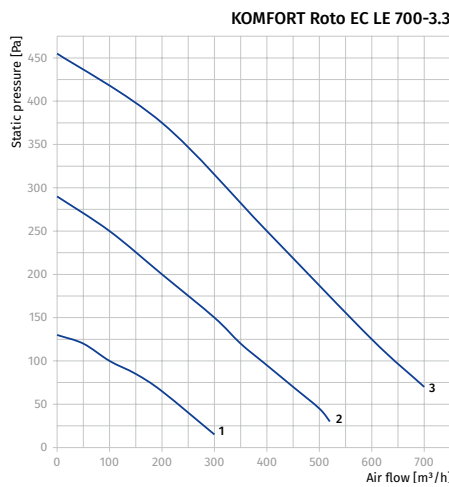
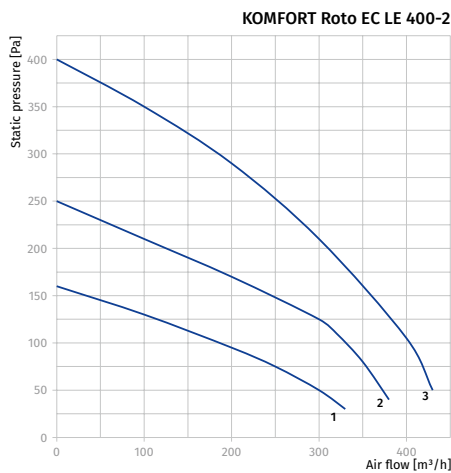

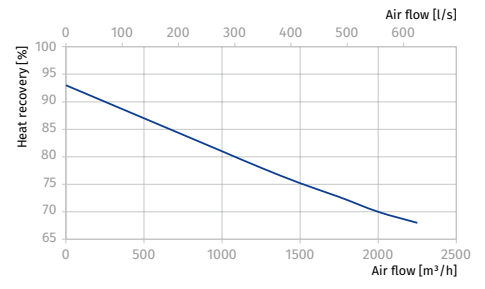
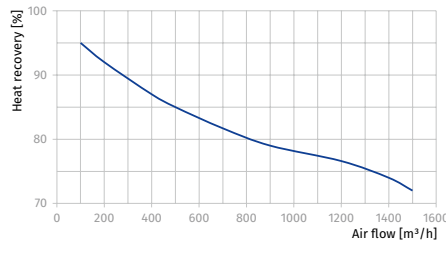
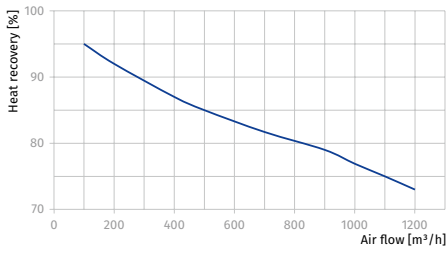
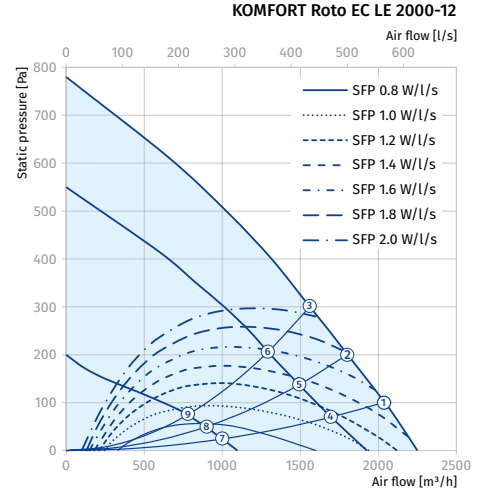
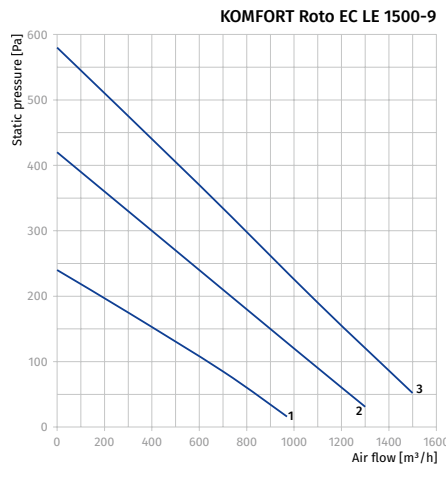
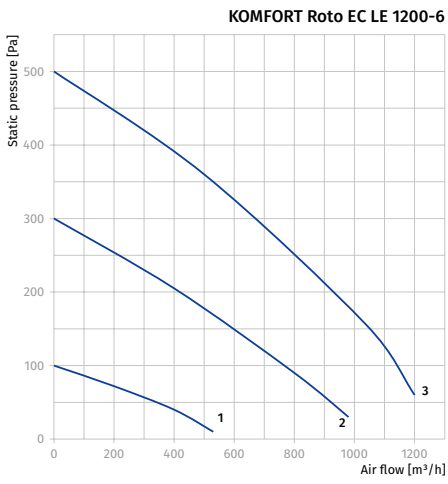

**Total power of the unit, W**

Point	KOMFORT Roto EC LE 2000-12
1	874
2	893
3	905
4	545
5	562
6	568
7	181
8	182
9	184

Parameters	KOMFORT Roto EC LW 400-2 S17/S18	KOMFORT Roto EC LW 700-2 S17/S18	KOMFORT Roto EC LW 1000-2 S17/S18	KOMFORT Roto EC LW 1200-2 S17/S18	KOMFORT Roto EC LW 1500-2 S17/S18	KOMFORT Roto EC LW 2000-2 S17/S18
Voltage [V / 50 (60) Hz]	1 ~ 230	1 ~ 230	1 ~ 230	1 ~ 230	1 ~ 230	1 ~ 230
Max. power without electric heater [W]	2 items x 100	2 items x 105	2 items x 135	2 items x 208	2 items x 222	2 items x 448
Max. power with electric heater [W]	290	315	440	570	750	1070
Max. current with electric heater [A]	1.2	1.4	1.9	2.5	3.2	5
Maximum air flow [m³/h (l/s)]	400 (111)	700 (194)	900 (250)	1200 (333)	1500 (417)	2250 (625)
RPM [min <sup>-1</sup> ]	up to 3100	up to 2600	up to 2600	up to 1930	up to 2000	up to 3000
Sound pressure level at 3 m [dBA]	45	52	58	60	62	64
Transported air temperature [°C]	-25...+40	-25...+40	-25...+40	-25...+40	-25...+40	-25...+40
Casing material	aluzinc	aluzinc	aluzinc	aluzinc	aluzinc	aluzinc
Insulation	20 mm mineral wool	20 mm mineral wool	20 mm mineral wool	20 mm mineral wool	25 mm mineral wool	25 mm mineral wool
Extract filter	G4	G4	G4	G4	G4	G4
Supply filter	G4	G4	G4	G4	G4	G4
Connected air duct diameter [mm]	160	250	250	315	315	500x300
Weight [kg]	112	128	130	165	175	198
Heat recovery efficiency [%]	80-95	76-95	72-95	73-95	72-95	68-93
Heat exchanger type	up to 85	up to 85	up to 85	up to 85	up to 85	up to 85
Heat exchanger type	rotary	rotary	rotary	rotary	rotary	rotary
Heat exchanger material	aluminium	aluminium	aluminium	aluminium	aluminium	aluminium
SEC class	A	A	A	NRVU*	NRVU*	NRVU*
ErP	2016, 2018	2016, 2018	2016, 2018	2016, 2018	2016, 2018	2016, 2018

\*Nonresidential Ventilation Unit.

AIR HANDLING UNITS WITH ROTARY HEAT EXCHANGER

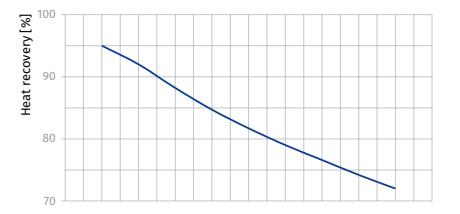
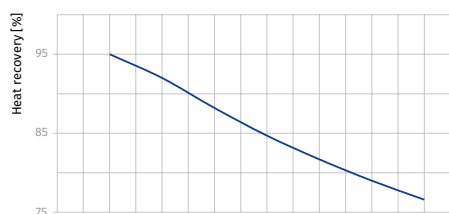
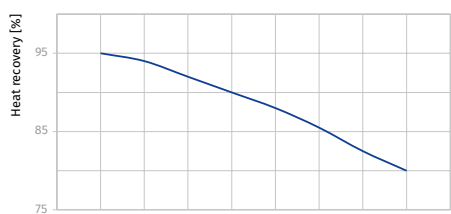
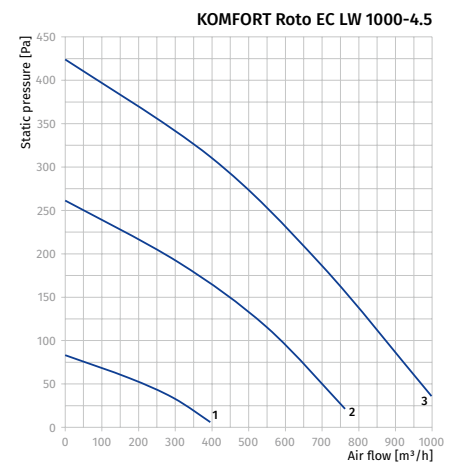
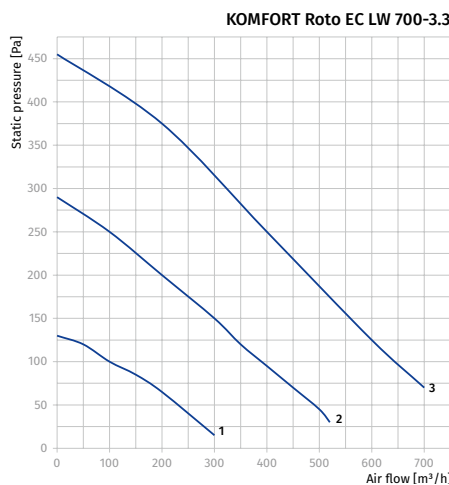
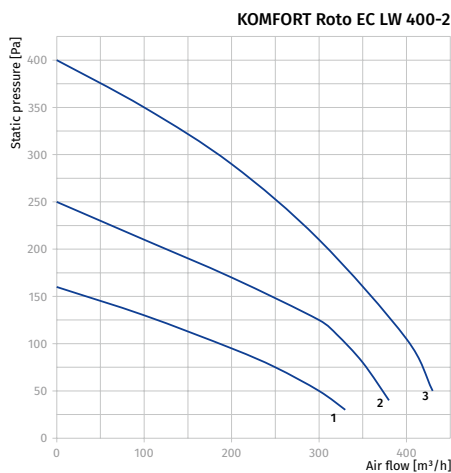

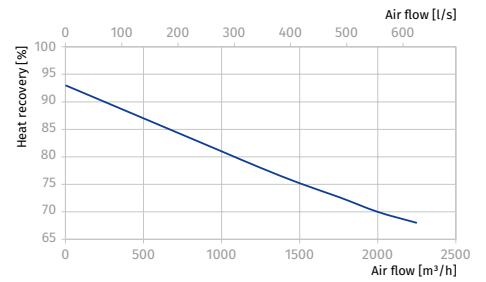
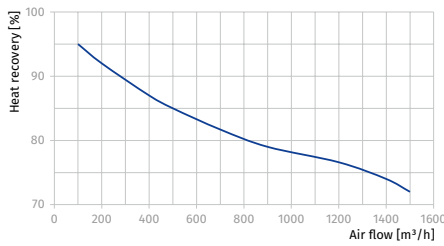
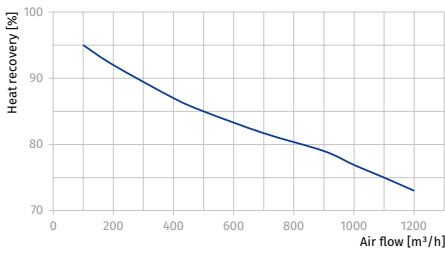
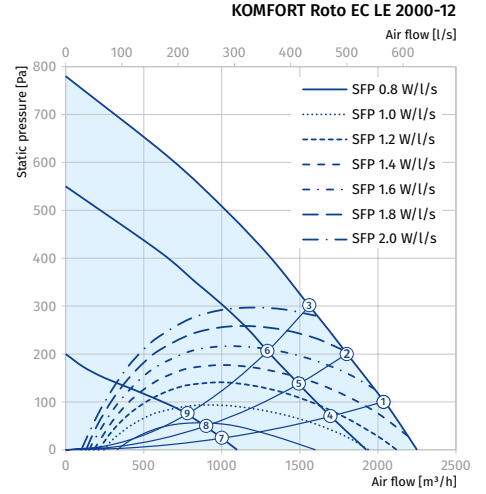
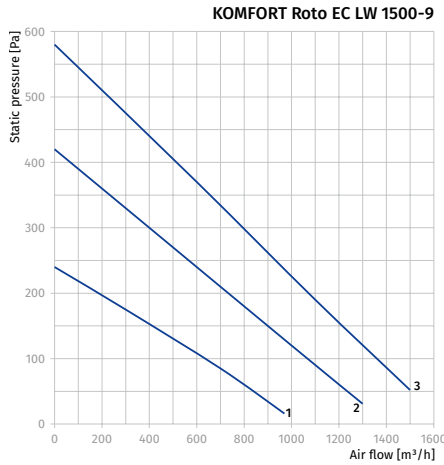
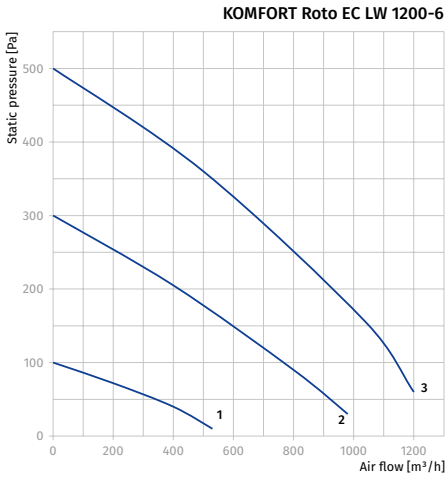

**Total power of the unit, W**

Point	KOMFORT Roto EC LE 2000-12
1	874
2	893
3	905
4	545
5	562
6	568
7	181
8	182
9	184

### Calculation of water heater parameters of the unit

#### KOMFORT Roto EC LW 400-2 / KOMFORT Roto EC LW 700-2 / KOMFORT Roto EC LW 1000-2

Air temperature downstream of the water heating coils [°C]

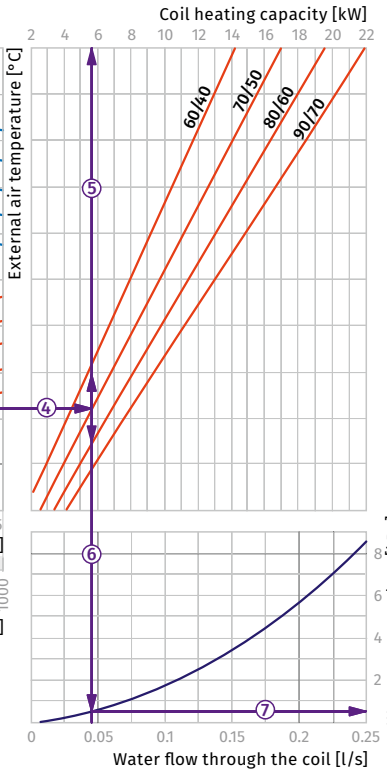
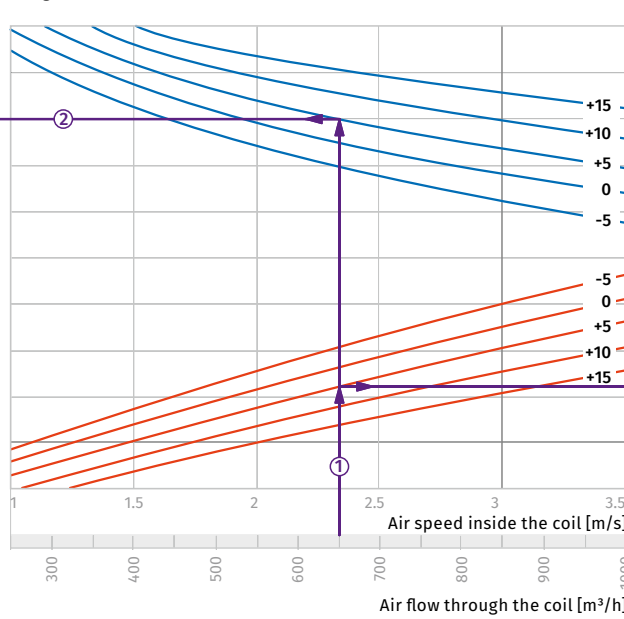
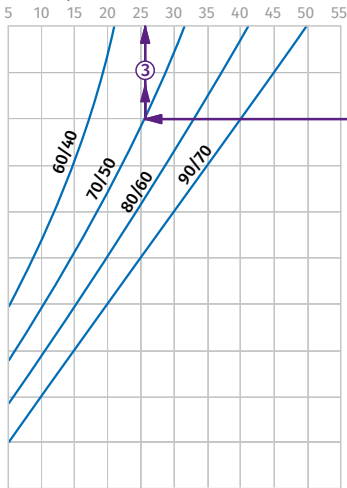

**How to use water heater diagrams.**

Sample parameters: Air flow = 650 m<sup>3</sup>/h.  
Outside air temperature = +5 °C.  
Water temperature (in/out) = +70/+50 °C.  
The air flow is 650 m<sup>3</sup>/h and the air speed in the heater is 2.35 m/s ①.

- To calculate the maximum air temperature find the intersection point of the air flow line ① with the rated outer temperature shown in blue line (e.g., +5 °C) and draw the line ② to the left until it crosses the water in/out temperature curve (e.g., +70/+50). From this point draw a vertical line to the supply air temperature downstream of the heater (+26 °C) ③.

- To calculate the heater power find the intersection point of the air flow ① with the rated winter temperature shown in red line (e.g., +5 °C) and draw the line ④ to the right until it crosses the water in/out temperature curve (e.g., +70/+50). From this point draw a vertical line to the heater power axis (5.8 kW) ⑤.

- To calculate the required water flow in the heater prolong this line ⑥ downwards to the water flow axis (0.04 l/s).
- To calculate the water pressure drop in the heater find the intersection point of the line ⑥ with the pressure loss curve and prolong the line ⑦ to the right on the water pressure drop axis (0.5 kPa).

#### KOMFORT ROTO EC LW 1200-2

Air temperature downstream of the water heating coils [°C]

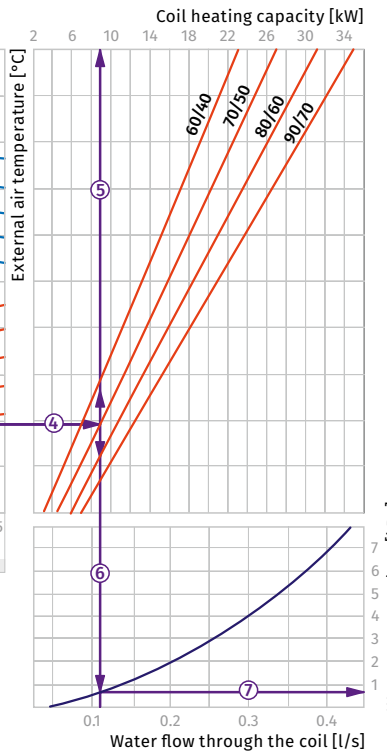
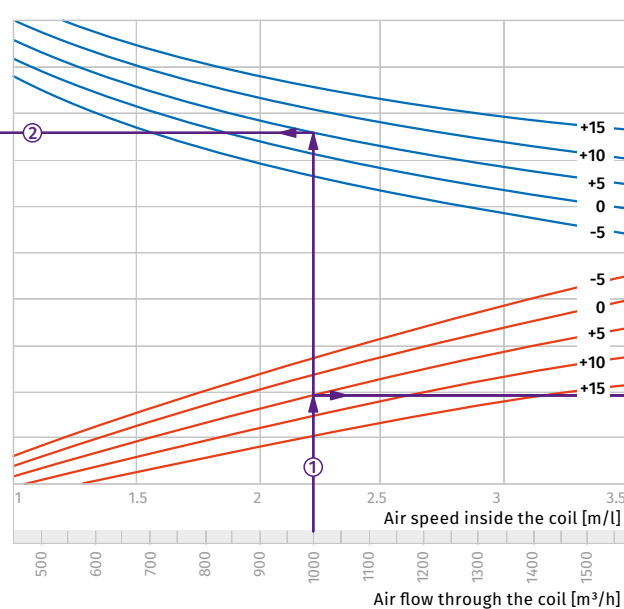
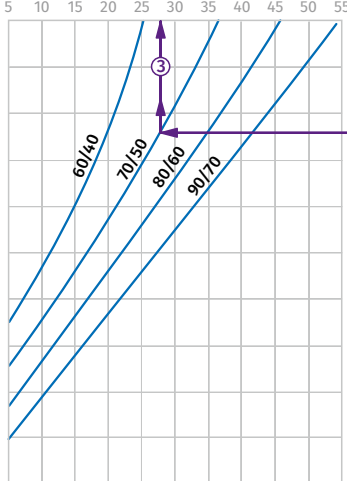

**How to use water heater diagrams.**

Sample parameters: Air flow = 1000 m<sup>3</sup>/h.  
Outside air temperature = +5 °C.  
Water temperature (in/out) = +70/+50 °C.  
The air flow is 1000 m<sup>3</sup>/h and the air speed in the heater is 2.22 m/s ①.

- To calculate the maximum air temperature find the intersection point of the air flow line ① with the rated outer temperature shown in blue line (e.g., +5 °C) and draw the line ② to the left until it crosses the water in/out temperature curve (e.g., +70/+50). From this point draw a vertical line to the supply air temperature downstream of the heater (+28 °C) ③.

- To calculate the heater power find the intersection point of the air flow ① with the rated winter temperature shown in red line (e.g., +5 °C) and draw the line ④ to the right until it crosses the water in/out temperature curve (e.g., +70/+50). From this point draw a vertical line to the heater power axis (9.0 kW) ⑤.

- To calculate the required water flow in the heater prolong this line ⑥ downwards to the water flow axis (0.11 l/s).
- To calculate the water pressure drop in the heater find the intersection point of the line ⑥ with the pressure loss curve and prolong the line ⑦ to the right on the water pressure drop axis (0.8 kPa).

AIR HANDLING UNITS WITH ROTARY HEAT EXCHANGER

**KOMFORT ROTO EC LW 1500-2 / KOMFORT ROTO EC LW 2000-2**

Air temperature downstream of the water heating coils [°C]

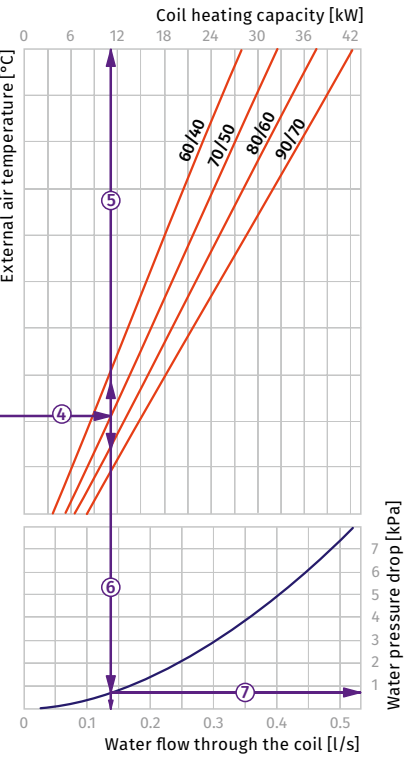
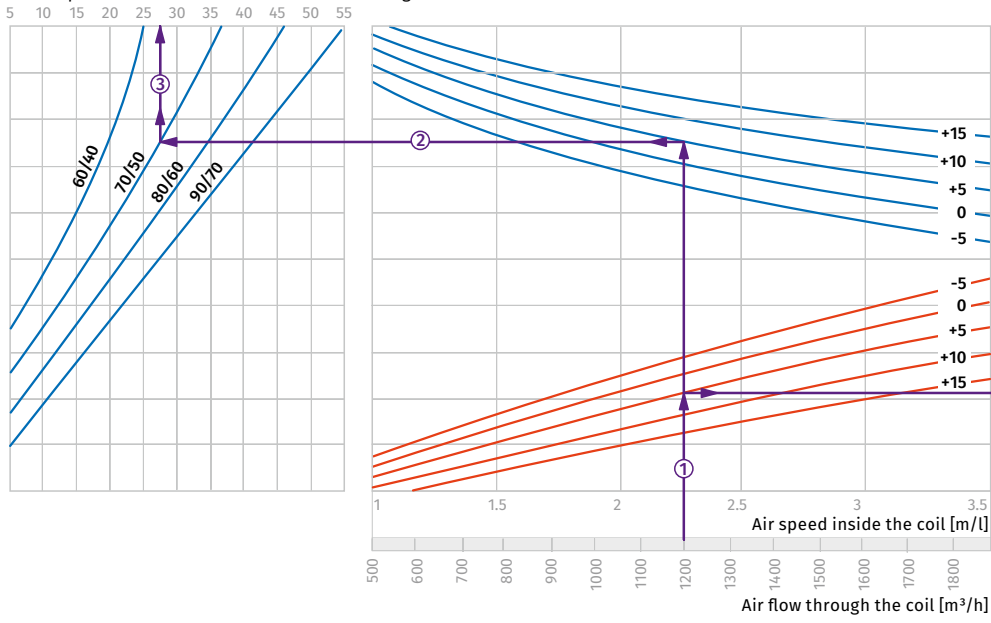













**How to use water heater diagrams.**

Sample parameters: Air flow = 1200 m<sup>3</sup>/h.  
 Outside air temperature = +5 °C.  
 Water temperature (in/out) = +70/+50 °C.  
 The air flow is 1200 m<sup>3</sup>/h and the air speed in the heater is 2.25 m/s ①.

- To calculate the maximum air temperature find the intersection point of the air flow line ① with the rated outer temperature shown in blue line (e.g., +5 °C) and draw the line ② to the left until it crosses the water in/out temperature curve (e.g., +70/+50). From this point draw a vertical line to the supply air temperature downstream of the heater (+27 °C) ③.
- To calculate the heater power find the intersection point of the air flow ① with the rated winter temperature shown in red line (e.g., +5 °C) and draw the line ④ to the right until it crosses the water in/out temperature curve (e.g., +70/+50). From this point draw a vertical line to the heater power axis (11.0 kW) ⑤.
- To calculate the required water flow in the heater prolong this line ⑥ downwards to the water flow axis (0.13 l/s).
- To calculate the water pressure drop in the heater find the intersection point of the line ⑥ with the pressure loss curve and prolong the line ⑦ to the right on the water pressure drop axis (0.8 kPa).



**Accessories**
**KOMFORT ROTO EC LE**

		KOMFORT Roto EC LE 400-2 S17/S18	KOMFORT Roto EC LE 700-3.3 S17/S18	KOMFORT Roto EC LE 1000-4.5 S17/S18	KOMFORT Roto EC LE 1200-6 S17/S18	KOMFORT Roto EC LE 1500-9 S17/S18	KOMFORT Roto EC LE 2000-12 S17/S18
G4 extract panel filter		FP 600x324x48 G4	FP 700x332x48 G4	FP 700x332x48 G4	FP 700x410x48 G4	FP 800x477x47 G4	FP 800x477x47 G4
G4 supply pocket filter		FPT 393x235x27 G4	FPT 700x333x27 G4	FPT 700x333x27 G4	FPT 700x423x27 G4	FPT 800x477x27 G4	FPT 800x477x27 G4
Silencer		SD 160	SD 250	SD 250	SD 315	SD 315	-
Backdraft air damper		VRV 160	VRV 250	VRV 250	VRV 315	VRV 315	-
Backdraft air damper		-	-	-	-	-	VRVS 500x300
Air damper		VRVS 160	VRVS 250	VRVS 250	VRVS 315	VRVS 315	-
Air damper		-	-	-	-	-	VK 500x300
VOC sensor		DPWQ30600	DPWQ30600	DPWQ30600	DPWQ30600	DPWQ30600	DPWQ30600
External CO <sub>2</sub> sensor		DPWQ40200	DPWQ40200	DPWQ40200	DPWQ40200	DPWQ40200	DPWQ40200
Humidity sensor		DPWC11200	DPWC11200	DPWC11200	DPWC11200	DPWC11200	DPWC11200
Humidity sensor		HR-S	HR-S	HR-S	HR-S	HR-S	HR-S
Humidity sensor		FS2	FS2	FS2	FS2	FS2	FS2
Electric actuator		TF230	TF230	TF230	TF230	TF230	TF230

AIR HANDLING UNITS WITH ROTARY HEAT EXCHANGER

**KOMFORT ROTO EC LW**

		KOMFORT Roto EC LW 400-2 S17/S18	KOMFORT Roto EC LW 700-2 S17/S18	KOMFORT Roto EC LW 1000-2 S17/S18	KOMFORT Roto EC LW 1200-2 S17/S18	KOMFORT Roto EC LW 1500-2 S17/S18	KOMFORT Roto EC LW 2000-2 S17/S18
G4 extract panel filter		FP 600x324x48 G4	FP 700x332x48 G4	FP 700x332x48 G4	FP 700x410x48 G4	FP 800x477x47 G4	FP 800x477x47 G4
G4 supply pocket filter		FPT 393x235x27 G4	FPT 700x333x27 G4	FPT 700x333x27 G4	FPT 700x423x27 G4	FPT 800x477x27 G4	FPT 800x477x27 G4
Water mixing unit		WMG 3/4-4	WMG 3/4-4	WMG 3/4-4	WMG 3/4-4	WMG 1-6	WMG 1-6
Silencer		SD 160	SD 250	SD 250	SD 315	SD 315	-
Backdraft air damper		VRV 160	VRV 250	VRV 250	VRV 315	VRV 315	-
Backdraft air damper		-	-	-	-	-	VRVS 500x300
Air damper		VRVS 160	VRVS 250	VRVS 250	VRVS 315	VRVS 315	-
Air damper		-	-	-	-	-	VK 500x300
VOC sensor		DPWQ30600	DPWQ30600	DPWQ30600	DPWQ30600	DPWQ30600	DPWQ30600
External CO <sub>2</sub> sensor		DPWQ40200	DPWQ40200	DPWQ40200	DPWQ40200	DPWQ40200	DPWQ40200
Humidity sensor		DPWC11200	DPWC11200	DPWC11200	DPWC11200	DPWC11200	DPWC11200
Humidity sensor		HR-S	HR-S	HR-S	HR-S	HR-S	HR-S
Humidity sensor		FS2	FS2	FS2	FS2	FS2	FS2
Electric actuator		TF230	TF230	TF230	TF230	TF230	TF230

AIR HANDLING UNITS WITH ROTARY HEAT EXCHANGER