



## **SINGLE-ROOM AIR HANDLING UNIT WITH HEAT RECOVERY**



**KOMFORT Roto EC D 351 L**  
**KOMFORT Roto EC D 351 R**  
**KOMFORT Roto EC DE 351 L**  
**KOMFORT Roto EC DE 351 R**  
**KOMFORT Roto EC D 351-E L**  
**KOMFORT Roto EC D 351-E R**  
**KOMFORT Roto EC DE 351-E L**  
**KOMFORT Roto EC DE 351-E R**

**EN**

**USER'S MANUAL**

**CONTENTS**

Safety requirements.....	3
Purpose.....	5
Delivery set.....	5
Designation key.....	5
Technical data.....	6
Design and operating principle .....	8
Mounting and set-up.....	9
Connection to power mains .....	14
Technical maintenance.....	16
Troubleshooting.....	18
Storage and transportation regulations.....	18
Manufacturer's warranty .....	19
Certificate of acceptance.....	23
Seller information .....	23
Installation certificate.....	23
Warranty card.....	23

This user's manual is a main operating document intended for technical, maintenance, and operating staff.

The manual contains information about purpose, technical details, operating principle, design, and installation of the KOMFORT Roto EC D(E) 351(-E) unit and all its modifications.

Technical and maintenance staff must have theoretical and practical training in the field of ventilation systems and should be able to work in accordance with workplace safety rules as well as construction norms and standards applicable in the territory of the country.

## **SAFETY REQUIREMENTS**

This unit is not intended for use by persons (including children) with reduced physical, sensory or mental capabilities, or lack of experience and knowledge, unless they have been given supervision or instruction concerning use of the unit by a person responsible for their safety. Children should be supervised to ensure that they do not play with the unit.

This appliance can be used by children aged from 8 years and above and persons with reduced physical, sensory or mental capabilities or lack of experience and knowledge if they have been given supervision or instruction concerning use of the appliance in a safe way and understand the hazards involved.

Cleaning and user maintenance shall not be done by children without supervision.

Children shall not play with the appliance.

Connection to the mains must be made through a disconnecting device, which is integrated into the fixed wiring system in accordance with the wiring rules for design of electrical units, and has a contact separation in all poles that allows for full disconnection under overvoltage category III conditions.

Do not attach the product to the support using glue or adhesives. Use only the fastening method specified in the "User's manual".

Ensure that the unit is switched off from the supply mains before removing the guard.

Precautions must be taken to avoid the back-flow of gases into the room from the open flue of gas or other fuel-burning appliances.

The appliance may adversely affect the safe operation of appliances burning gas or other fuels (including those in other rooms) due to back flow of combustion gases. These gases can potentially result in carbon monoxide poisoning. After installation of the unit the operation of flued gas appliances should be tested by a competent person to ensure that back flow of combustion gases does not occur.

All operations described in this manual must be performed by qualified personnel only, properly trained and qualified to install, make electrical connections and maintain ventilation units.

Do not attempt to install the product, connect it to the mains, or perform maintenance yourself. This is unsafe and impossible without special knowledge.

Disconnect the power supply prior to any operations with the unit.

All user's manual requirements as well as the provisions of all the applicable local and national construction, electrical, and technical norms and standards must be observed when installing and operating the unit.

Disconnect the unit from the power supply prior to any connection, servicing, maintenance, and repair operations.

Connection of the unit to power mains is allowed by a qualified electrician with a work permit for the electric units up to 1000 V after careful reading of the present user's manual.

Check the unit for any visible damage of the impeller, the casing, and the grille before starting installation. The casing internals must be free of any foreign objects that can damage the impeller blades.

While mounting the unit, avoid compression of the casing! Deformation of the casing may result in motor jam and excessive noise.

Misuse of the unit and any unauthorised modifications are not allowed.

Do not expose the unit to adverse atmospheric agents (rain, sun, etc.).

Transported air must not contain any dust or other solid impurities, sticky substances, or fibrous materials.

Do not use the unit in a hazardous or explosive environment containing spirits, gasoline, insecticides, etc.

Do not close or block the intake or extract vents in order to ensure the efficient air flow.

Do not sit on the unit and do not put objects on it.

The information in this user's manual was correct at the time of the document's preparation.

The Company reserves the right to modify the technical characteristics, design, or configuration of its products at any time in order to incorporate the latest technological developments.

Never touch the unit with wet or damp hands.

Never touch the unit when barefoot.

**BEFORE INSTALLING ADDITIONAL EXTERNAL DEVICES, READ THE RELEVANT USER MANUALS.**



**THE PRODUCT MUST BE DISPOSED SEPARATELY AT THE END OF ITS SERVICE LIFE.**

**DO NOT DISPOSE THE UNIT AS UNSORTED DOMESTIC WASTE.**

**PURPOSE**

The unit is designed to ensure continuous mechanical air exchange in houses, offices, hotels, cafés, conference halls, and other utility and public spaces to recover the heat energy contained in the air extracted from the premises and warm up the filtered stream of supply air, as well as for exhaust ventilation in kitchens, commercial bakeries etc.

The unit is not intended for organizing ventilation in swimming pools, saunas, greenhouses, summer gardens, and other spaces with high humidity.

Due to the ability to save heating energy by means of energy recovery, the unit is an important element of energy-efficient technologies for premises.

The unit is a component part and is not designed for stand-alone operation.

The unit is rated for continuous operation.

Transported air must not contain any flammable or explosive mixtures or chemical vapors.

**DELIVERY SET**

Name	Number
Unit	1 pc.
User's manual	1 pc.
Packing box	1 pc.

**DESIGNATION KEY**

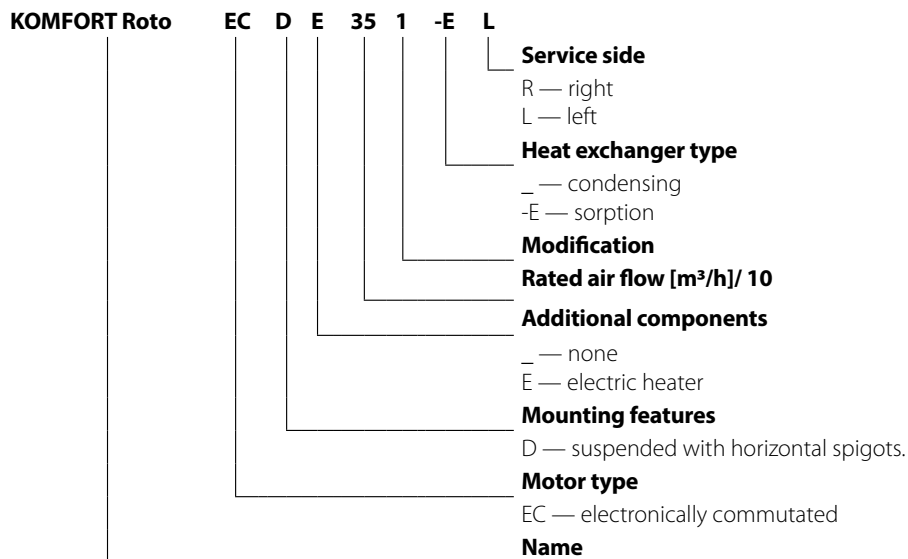

**TECHNICAL DATA**

The unit is designed for indoor application with the ambient temperature ranging from +1 °C up to +40 °C and relative humidity up to 60 % without condensation. In cold, damp rooms, there is a possibility of freezing or condensation inside and outside the casing.

In order to prevent condensation on the internal walls of the unit, it is necessary that the surface temperature of the casing is 2-3 °C above the dew point temperature of the transported air.

The unit should be operated continuously, and in cases where ventilation is not necessary, reduce the air flow of the fans to a minimum (20%). This will ensure a favorable indoor climate and reduce the amount of condensation inside the unit, which can damage electronic components. Never use the unit for dehumidification, for example, of new buildings.

The unit is rated as a Class I electrical appliance.

Hazardous parts access and water ingress protection rating:

IP22 for the unit connected to the air ducts

IP44 for the unit motors

The unit design is constantly being improved, thus some models may be slightly different from those described in this manual.

**TECHNICAL DATA**

Parameter	KOMFORT Roto ECD 351	KOMFORT Roto EC D 351(-E)	KOMFORT Roto EC DE 351	KOMFORT Roto EC DE 351(-E)
Power supply voltage [V/50-60 Hz]	230			
Maximum unit power without the heater [W]	211			
Maximum heater power [W]	—	—	1200	1200
Maximum unit power [W]	211	211	1261	1261
Maximum unit current without the heater [A]	1.54			
Maximum heater current [A]	—	—	5.32	5.32
Maximum unit current [A]	1.54	1.54	6.86	6.86
Maximum air flow [m³/h]	497			
Sound pressure level at 3 m [dBA]	39			
Transported air temperature [°C]	-25...+40			
Casing material:	Polymer-coated steel			
Insulation	Mineral wool, 40 mm			
Filter	extract	G4 / Coarse > 60%		
	supply	G4 / Coarse > 60% (option F7 / ePM1 60%)		
Connected air duct diameter [mm]	200			
Weight [kg]				
Heat recovery efficiency [%]	89	85	89	85
Heat exchanger type	Condensing	Sorption	Condensing	Sorption
SEC Class	A	A	A	A

KOMFORT Roto EC D(E) 351

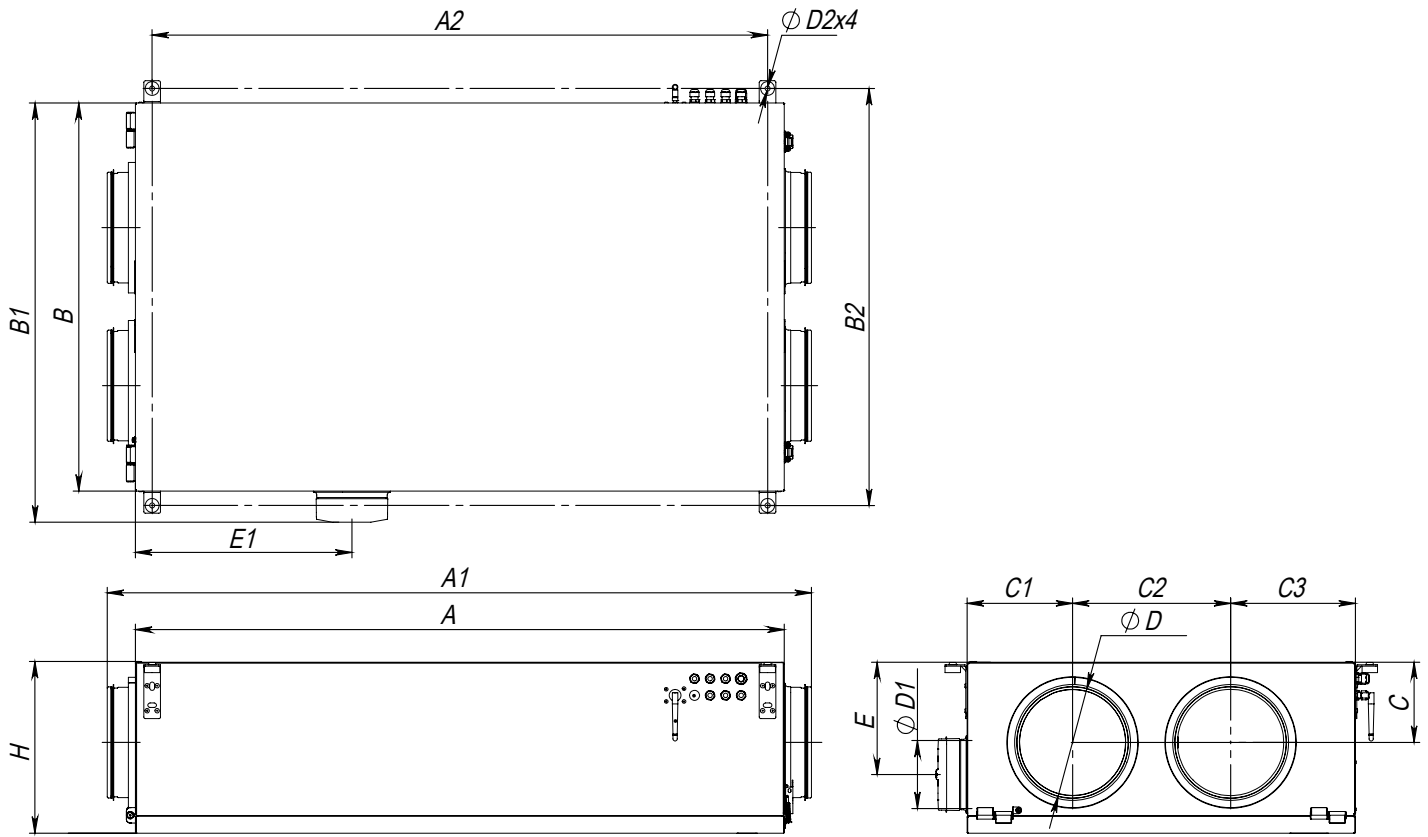

	D	D1	D2	A	B	H	A1	B1	A2	B2	C	C1	C2	C3	E	E1
KOMFORT Roto EC D(E) 351	200	123	9	1170	700	310	1270	756	1110	752	145	190	285	225	203	390

## DESIGN AND OPERATING PRINCIPLE

The unit operation is as follows: warm, stale extract air flows through the air ducts into the unit and is filtered. Then the air is moved through the rotary heat exchanger and is exhausted outside through the air ducts with the extract fan.

Cold fresh intake air flows through the air ducts into the unit's supply filter, where it is filtered. Then the air is moved through the rotary heat exchanger and electric heater (for the KOMFORT Roto EC DE 351(-E) units), where the air is warmed up, and is supplied through the air ducts into the room by means of the supply fan.

Heat energy of warm extract air in the rotary heat exchanger is transferred to clean, cold intake air from the outside and warms it up. Heat recovery minimizes heat energy losses and operational costs for heating premises in the cold season and cooling premises in the warm season.

The unit enables the possibility of installing a range hood. Remove the plug from the corresponding spigot to connect the hood. The hood must be equipped with a valve blocking the exhaust air duct when the hood is not used.

### SERVICE PANEL SIDE VIEW

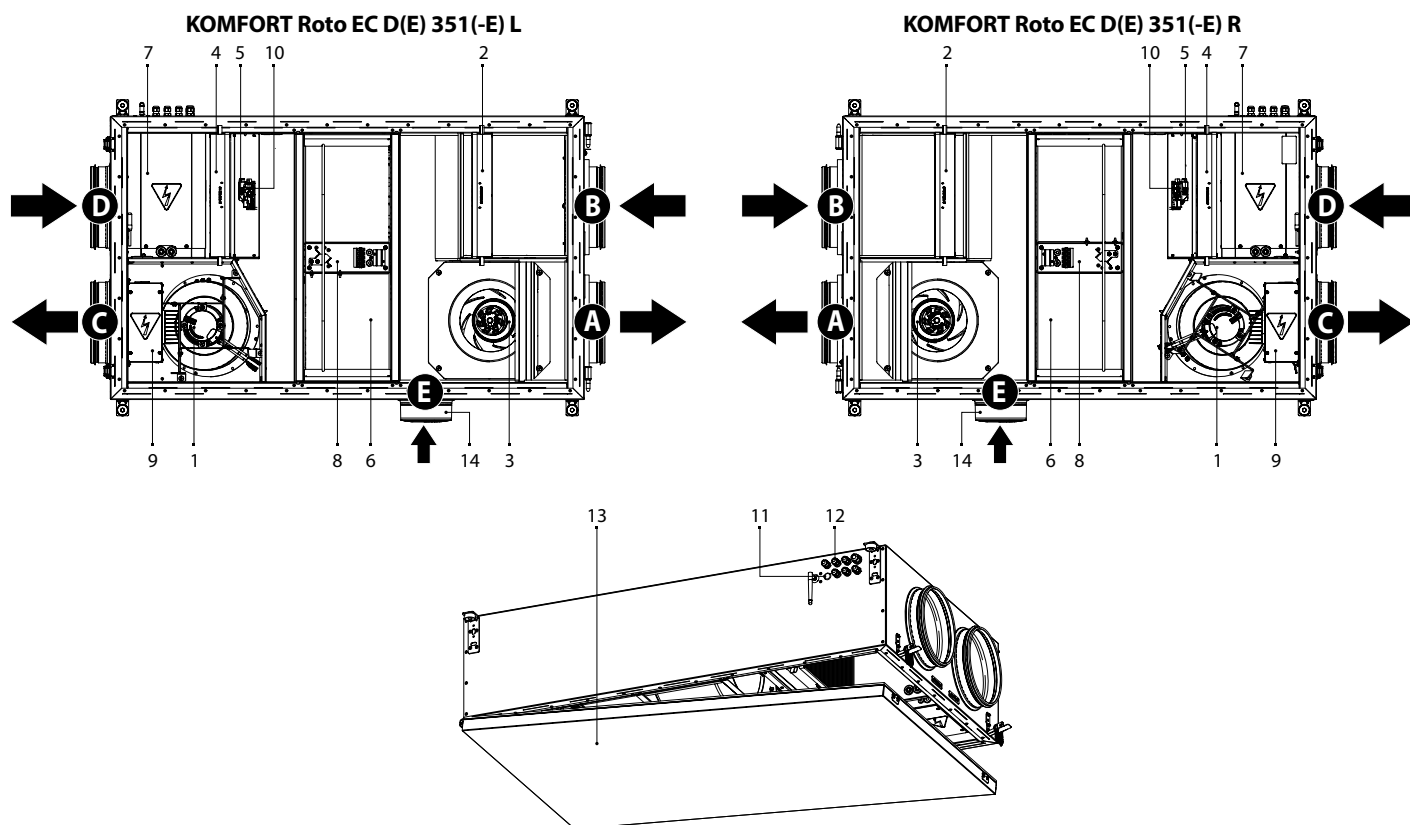

1 — supply fan; 2 — supply filter; 3 — extract fan; 4 — extract filter; 5 — humidity sensor (option); 6 — rotary heat exchanger; 7 — control unit; 8 — rotary heat exchanger actuator; 9 — electric heater (the KOMFORT Roto EC DE 351(-E) model); 10 — CO<sub>2</sub> sensor (option); 11 — Setup Mode button; 12 — cable glands; 13 — service panel; 14 — plug.  
A — exhaust air, B — intake air, C — supply air, D — extract air, E — from the range hood



**MOUNTING AND SET-UP**



**READ THE USER'S MANUAL BEFORE INSTALLING THE UNIT.**



**THE UNIT MUST BE MOUNTED BY A QUALIFIED EXPERT ONLY, PROPERLY TRAINED AND HAVING THE REQUIRED TOOLS AND MATERIALS.**

The units are available in left-hand and right-hand design. Choosing the right design can improve the ease of installation, shorten the length of the ducts and reduce the number of air duct bends.

While mounting the unit provide the minimum required access to the unit for maintenance and repair. The recommended minimum distances from the unit to the walls are shown below.

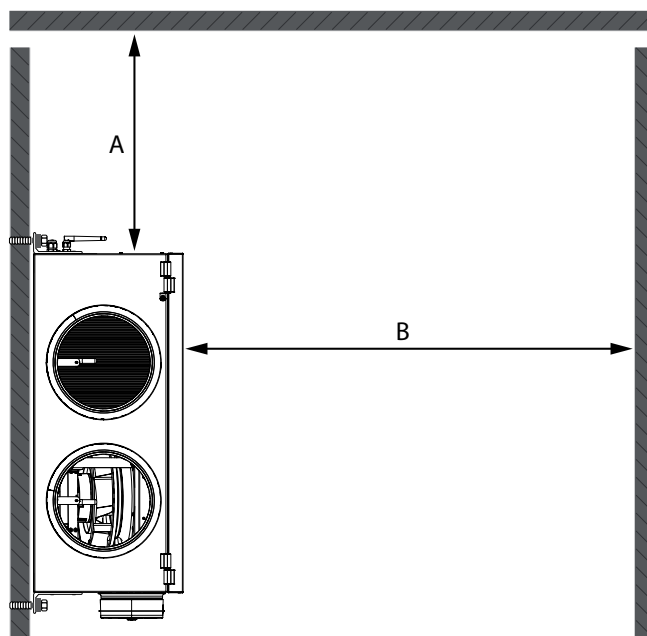
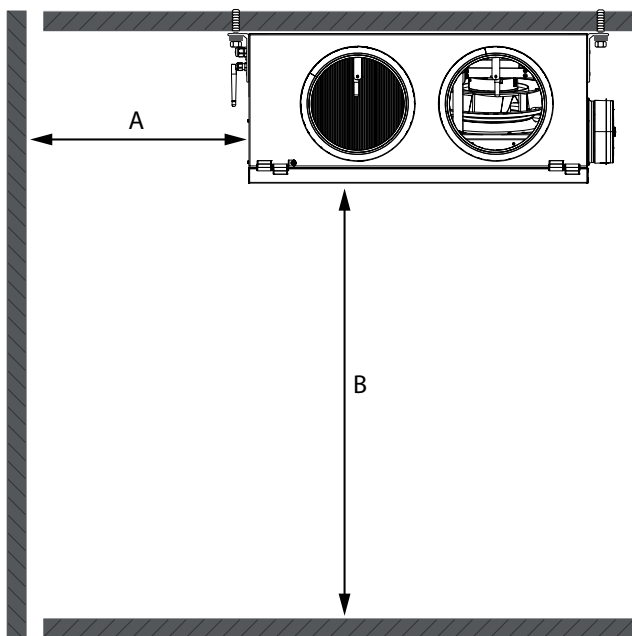

A — min 300 mm, B — min 1200 mm

To attain the best performance of the unit and to minimise turbulence-induced air pressure losses connect straight air duct sections to the unit spigots on both sides of the unit.

The minimum straight air duct length is equal to:

- 1 air duct diameter on the intake side;
- 3 air duct diameters on outlet side

The air ducts must be slipped over the unit flanges until tight. Flexible air ducts must be rigidly fixed with a metal worm clamp.

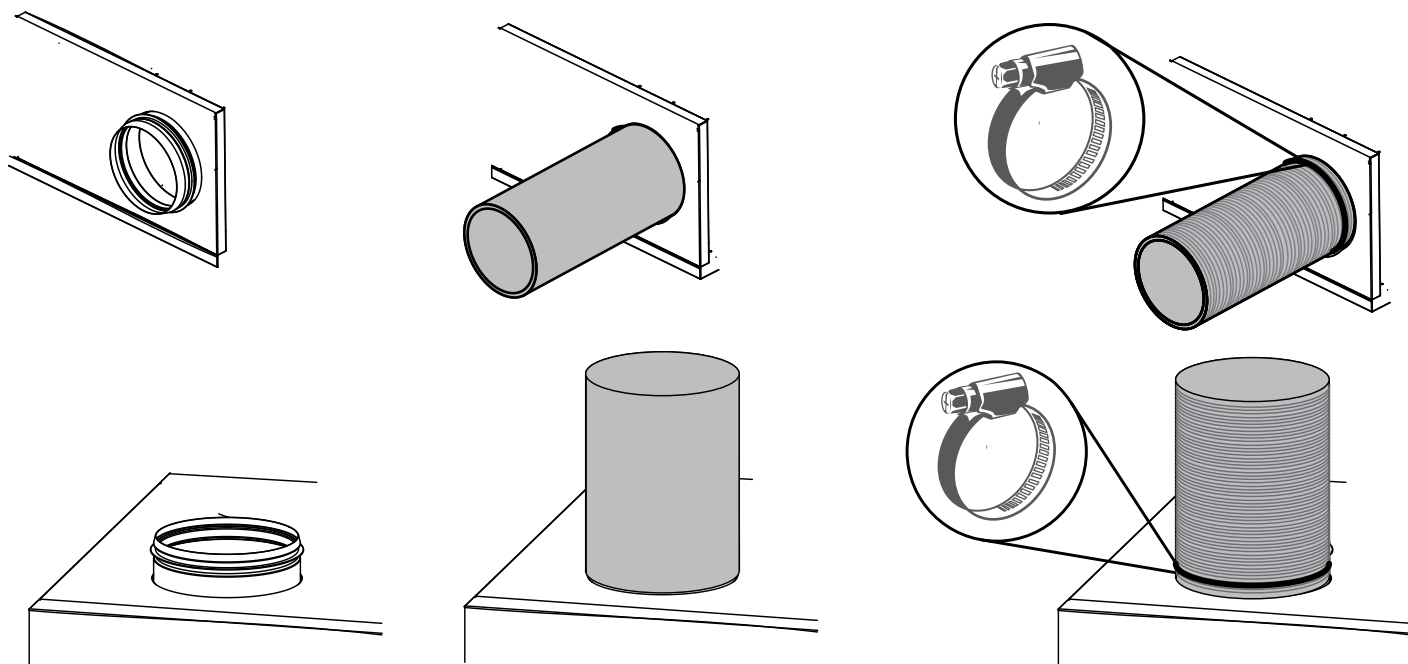

If the air ducts are too short or not connected, protect the unit parts from ingress of foreign objects. To prevent uncontrollable access to the fan the spigots may be covered with a protecting grille or other protecting device mesh width not more than 12.5 mm.

The horizontal outdoor air duct sections are recommended to be designed in a way that ensures a minimum slope to the outside to prevent ingress of melting snow and rain water into the system.

The outside spigots must be equipped with either a mechanical spring actuator or electric actuator to prevent adverse atmospheric effects on the unit when it is off.

The unit is designed for horizontal mounting or wall mounting using 4 screws and dowels (not included in the delivery set). While selecting appropriate fasteners consider the material of the mounting surface as well as the weight of the unit (refer to the technical data). For selection of the fasteners please refer to a service technician.

The surface for unit mounting must be smooth. Mounting the unit on an uneven surface causes the unit casing to skew, which may disrupt intended operation.

**SERVICE PANEL**

The unit is equipped with a hinged service panel for technical and maintenance operations. The unit design enables the user to remove the service panel.

Remove the hinge lock and disconnect the grounding wire to remove the service panel.

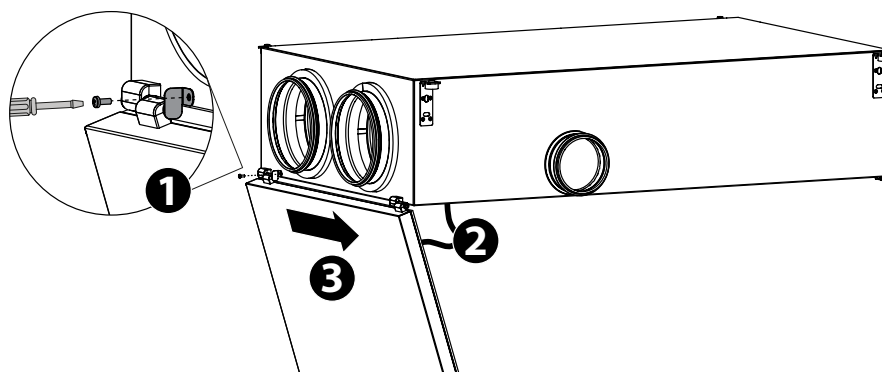

**INSTALLATION AND CONNECTION OF THE FS2 HUMIDITY SENSOR AND CO<sub>2</sub> SENSOR**

If the humidity and CO<sub>2</sub> sensors are not included in the delivery set, they can be ordered separately. The sensors must be installed before installing the unit.

The sensors installation sequence:

- secure the sensors on the exhaust air duct wall;
- plug in the connectors to sensors.

Remove the exhaust air filter to access the exhaust air duct's wall of the KOMFORT Roto EC D(E) 351(-E) L unit.

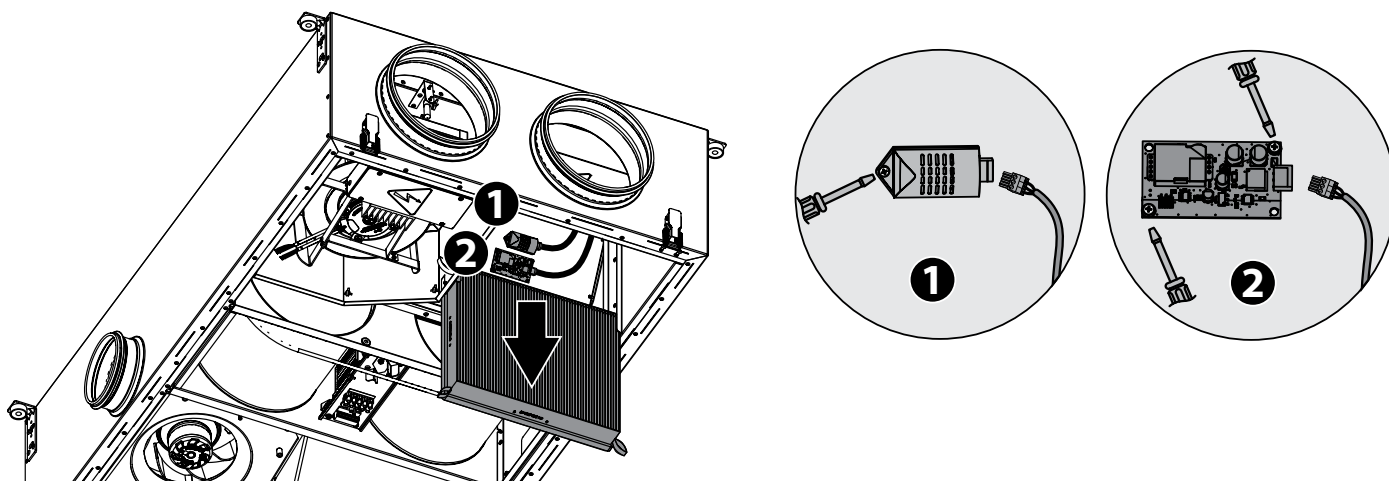

**SUSPENDED MOUNTING**

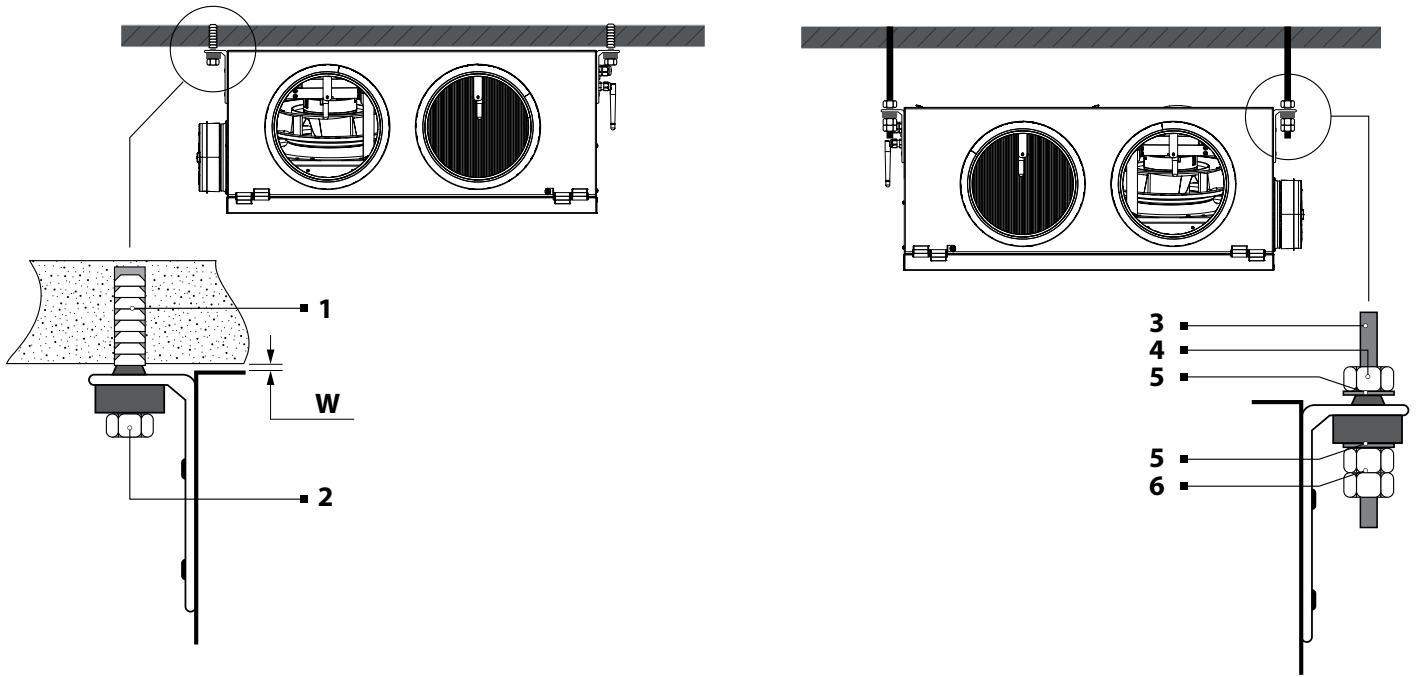

**WALL MOUNTING**

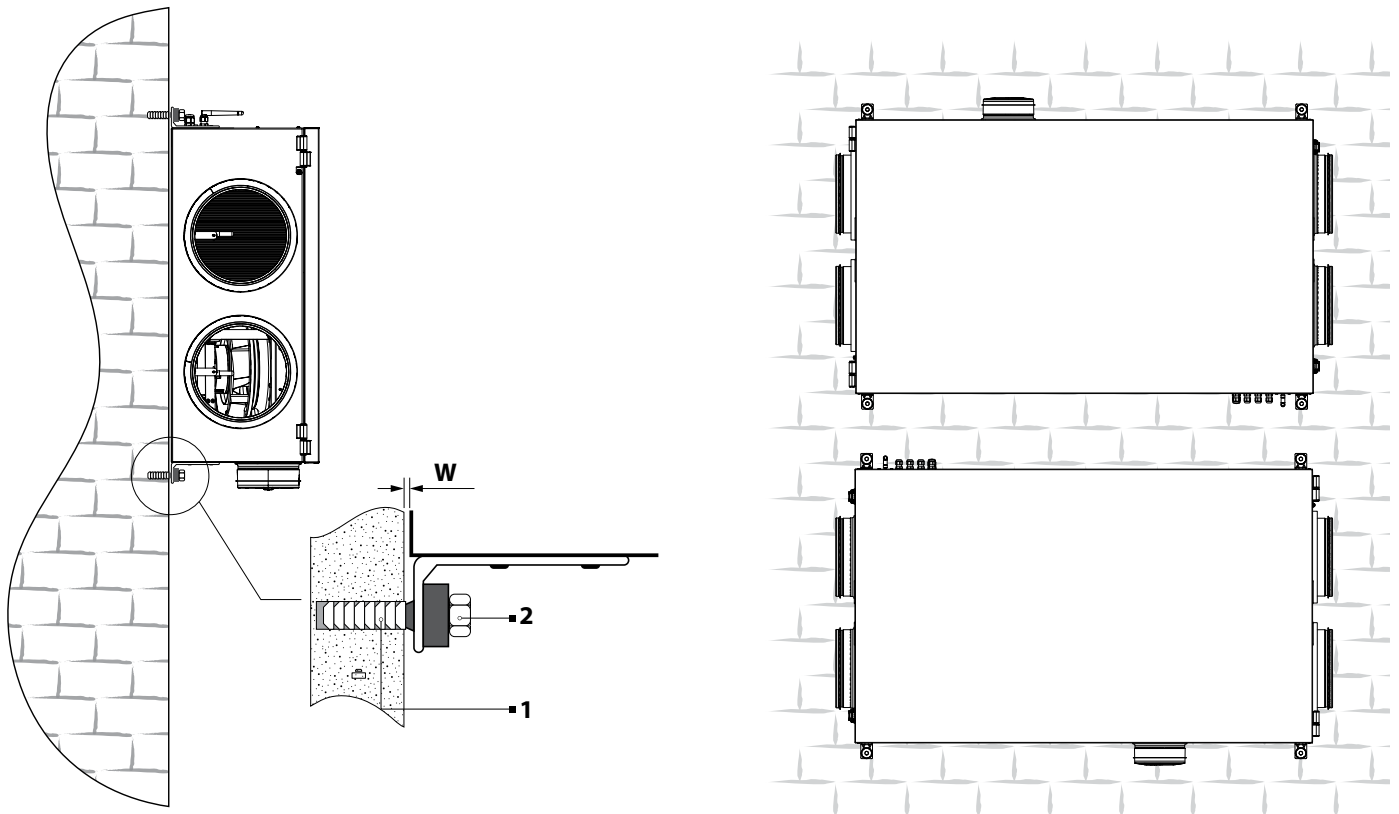

1 – dowel, 2 – screw, 3 – threaded rod, 4 – nut, 5 – washer, 6 – nut with a lock nut; W — 5 mm.

**UNIT DESIGN**

To ensure comfortable installation and provide space for accessing the unit, left and right design types of the unit are designed.

**KOMFORT Roto EC D(E) 351(-E) R**

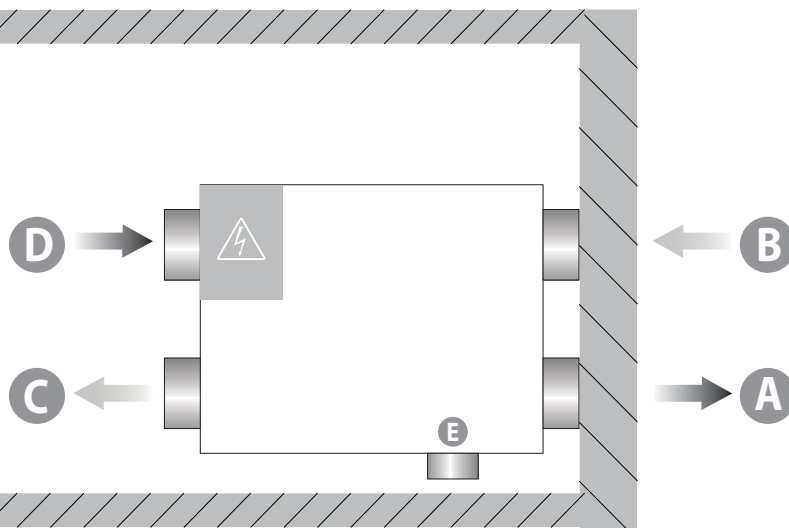

**KOMFORT Roto EC D(E) 351(-E) L**

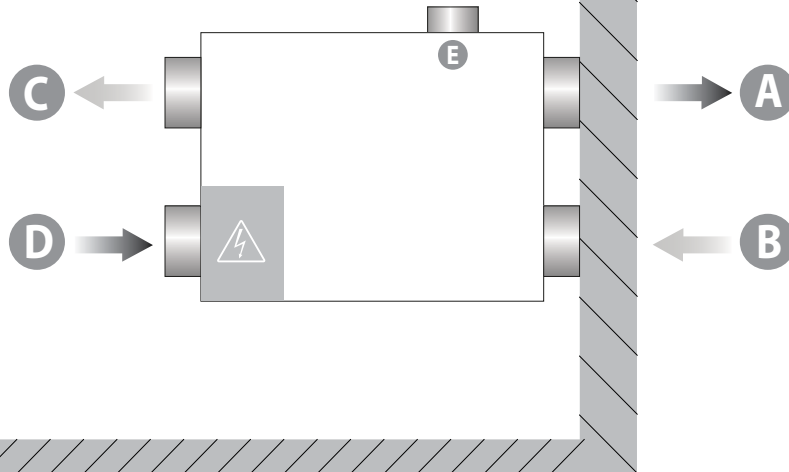

Top view

**KOMFORT Roto EC D(E) 351(-E) L**

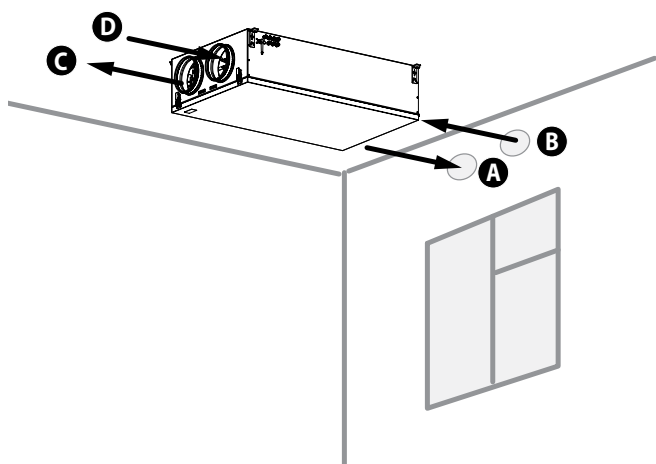

**KOMFORT Roto EC D(E) 351(-E) R**

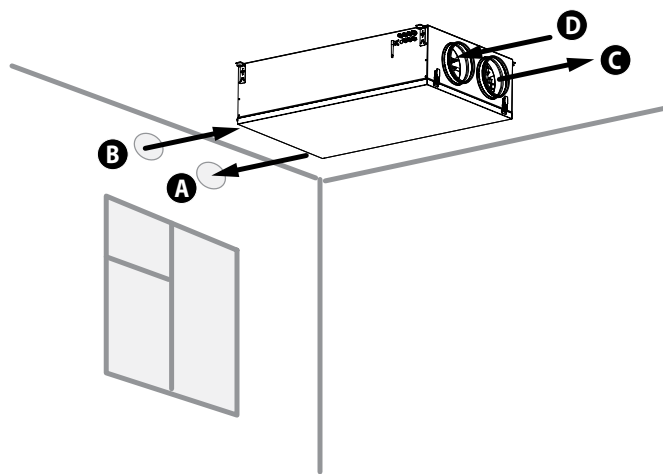

A – exhaust air, B – intake air, C – supply air, D – extract air, E – from the range hood

## CONNECTION TO POWER MAINS



**ANY TAMPERING WITH THE INTERNAL CONNECTIONS IS PROHIBITED AND WILL VOID THE WARRANTY.**

The unit is designed for connection to power mains with the parameters specified in the technical data table. The connection must be made using durable, insulated and heat-resistant conductors (cables, wires).

The external power input must be equipped with an automatic circuit breaker built into the stationary wiring to open the circuit in the event of overload or short-circuit.

The position of the external circuit breaker must ensure free access for quick unit power-off.

The trip current of the automatic circuit breaker must exceed the maximum current consumption of the unit (see the "Technical data" section or the unit label). It is recommended to select the rated current of the circuit breaker from the standard series, following the maximum current of the connected unit.

The circuit breaker is not included in the delivery set.

The actual wire cross section selection must be based on the maximum load current and maximum wire temperature allowed, depending on type its insulation, length and installation method.

To connect the power supply and external devices, unscrew the two screws on the cover of the control unit and remove the cover, as shown in the figure.

Lead the power supply cable, the cables for connecting the control panel and other cables into the control unit through the cable glands and connect them according to the wiring diagram.

Power cord and external wiring diagrams are shown in the figure below.

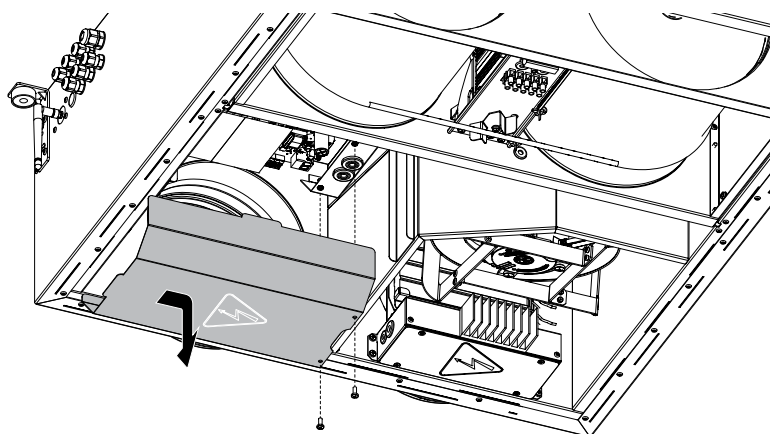

Access to the control unit



**DO NOT LAY THE CABLE IN CLOSE PROXIMITY AND PARALLEL TO THE CONTROL PANEL CABLE!  
DO NOT COIL THE CONTROL CABLE IN LOOPS WHILE LAYING IT.**



EXTERNAL WIRING DIAGRAM

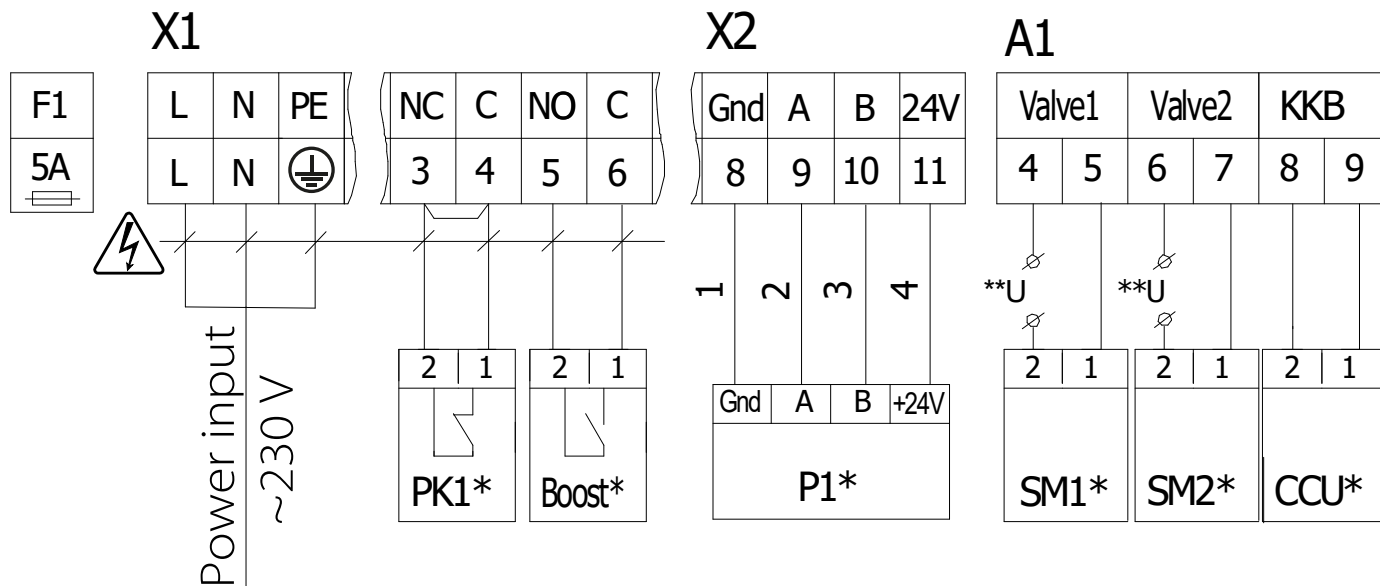

Designation	Name	Wire	Model	Note
SM1*	Supply damper actuator	2 x 0.75	NO	3A, 30VDC/~250VAC
SM2*	Exhaust damper actuator	2 x 0.75	NO	3A, 30VDC/~250VAC
PK1*	Contact from fire alarm panel	2 x 0.75	NC	Remove the jumper, ~250VAC
CCU*	Cooler control	2 x 0.75	NO	3A, 30VDC/~250VAC
P1*	External control panel	4 x 0.5		
Boost*	On/Off contacts of the Boost mode	2 x 0.75	NO	
F1	Fuse			5x20, slow
A1	Control board			

\* The product is not included in the delivery set.

\*\* The supply voltage U of the external dampers SM1, SM2 is selected based on the type of the damper.



## TECHNICAL MAINTENANCE



**DISCONNECT THE UNIT FROM POWER MAINS  
BEFORE ANY MAINTENANCE OPERATIONS!**

Maintenance operations of the unit are required 3-4 times per year. They include general cleaning of the unit and the following operations:

### 1. Filter maintenance.

Clogged filters increase air resistance in the system and reduce supply air volume.

The filters require cleaning not less than 3-4 times per year. Upon elapsing of 3000 operating hours the controller reminds about the need to replace or clean the filters. In this case clean or replace the filters and reset the filter timer. Filter cleaning with a vacuum cleaner is allowed. After two consecutive cleanings the filters must be replaced. For new filters, contact the Seller. Using filters manufactured by third parties will void the unit warranty.

Steps for removal of the filters:

1. Disconnect the unit from power supply;
2. Open the service panel;
3. Pull the filters to remove them.

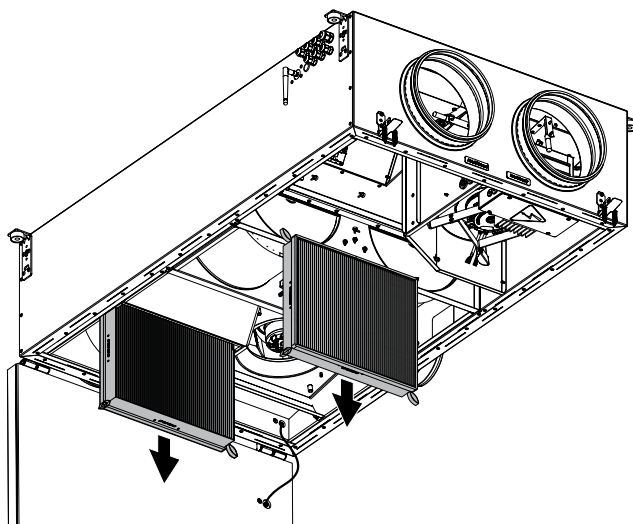

### 2. Heat exchanger maintenance (once per year).

Some dust may accumulate on the heat exchanger even in case of regular maintenance of the filters. To maintain the high heat recovery efficiency, regular cleaning is required. To clean the heat exchanger, remove it from the unit and clean the heat exchanger by using compressed air or a vacuum cleaner. After cleaning, re-install the heat exchanger into the unit.

Steps for removal of the heat exchanger:

1. Disconnect the unit from power supply;
2. Open the service panel;
3. Disconnect the heat exchanger and pull it to remove it.

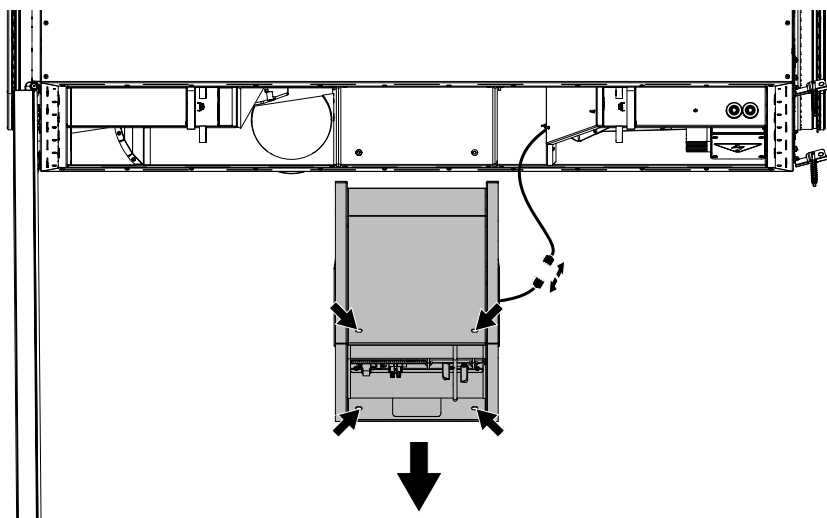



**3. Fan maintenance (once per year).**

Even in case of regular maintenance of the filters and the heat exchanger, some dust may accumulate inside the fans and reduce the fan performance and supply air flow.

Clean the fans with a soft brush or cloth.

Do not use water, aggressive solvents, or sharp objects as they may damage the impeller.

The fans removal sequence:

1. Disconnect the unit from power supply;
2. Open the service panel;
3. Unscrew the supporting screws and remove the guide plate over the exhaust fan;
4. Unscrew the supporting male screws and remove the in-built electric reheater (for KOMFORT Roto EC DE 351(-E) models);
5. Unscrew the supporting male screws and remove the fans;
6. Remove the fans.

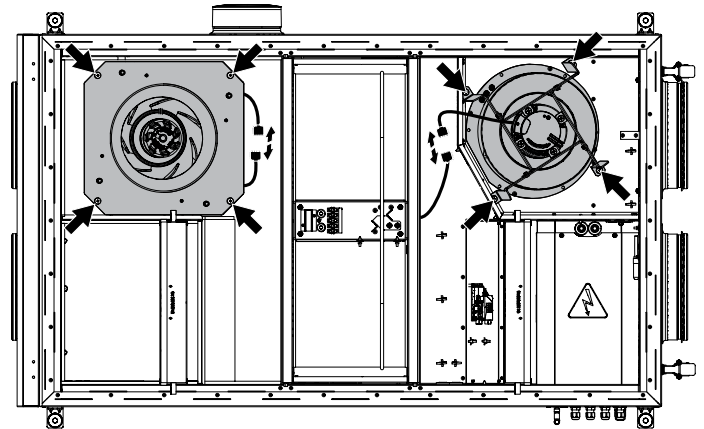
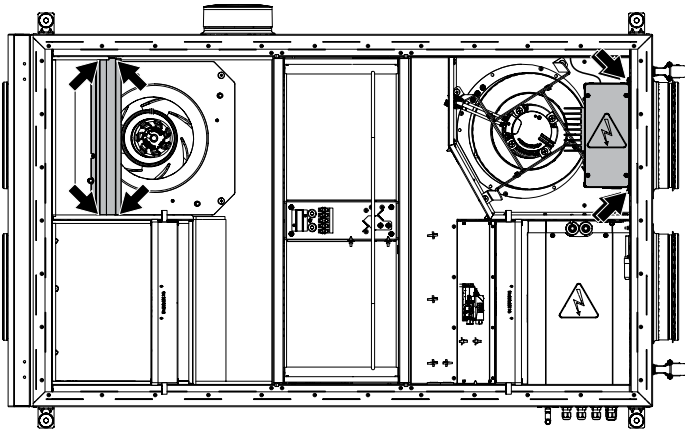
**4. Maintenance of air intake devices (twice per year).**

The supply grille may get clogged with leaves and other objects, which reduces the unit performance and supply air delivery. Check the supply grille twice per year and clean it as required.

**5. Ductwork system maintenance (once in 5 years).**

Even regular fulfilling of all the maintenance operations described above may not completely prevent dirt accumulation in the air ducts, which leads to air pollution and reduces the unit capacity.

Duct maintenance means regular cleaning or replacement.

## TROUBLESHOOTING

### Possible faults and troubleshooting

Problem	Possible reasons	Troubleshooting
The fan(s) does (do) not start when the unit is on.	No power supply.	Make sure the power supply line is connected correctly, otherwise troubleshoot the connection error.
	The motor is jammed, the impeller blades are clogged.	Turn the unit off. Troubleshoot the fan clogging. Clean the blades. Restart the unit.
Automatic circuit breaker trips following the unit turning on.	Overcurrent as a result of short circuit in the electric circuit.	Restart the unit. Contact the Seller.
Low air flow.	Low set fan speed.	Set higher speed.
	The filters and the fans are clogged, the heat exchanger is clogged.	Clean or replace the filters; clean the fans and the heat exchanger.
	Ventilation system elements (air ducts, diffusers, louver shutters, grilles) are clogged, damaged or closed.	Clean or replace the ventilation system elements, such as air ducts, diffusers, louver shutters, grilles.
Cold supply air.	The extract filter is soiled.	Clean or replace the extract filter.
	The unit is operating in the cooling mode.	Check the settings of the unit's operation mode.
Increased noise, vibration.	The impeller(s) is soiled.	Clean the impeller or impellers.
	The fan or casing screw connection is loose.	Tighten the screws of the fans or the casing against stop.
	No anti-vibration connectors on air duct pipe flanges.	Install anti-vibration connectors.

**If troubleshooting steps have failed, contact the Seller of the product.**

**If troubleshooting steps have failed, contact the Seller of the product.**

**In case of faults not described in the table, contact the Seller for further information.**

## STORAGE AND TRANSPORTATION REGULATIONS

- Store the unit in the manufacturer's original packaging box in a dry closed ventilated premise with temperature range +5 °C to + 40 °C and relative humidity up to 70 %.
- Storage environment must not contain aggressive vapors and chemical mixtures provoking corrosion, insulation, and sealing deformation.
- Use suitable hoist machinery for handling and storage operations to prevent possible damage to the unit.
- Follow the handling requirements applicable for the particular type of cargo.
- The unit can be carried in the original packaging by any mode of transport provided proper protection against precipitation and mechanical damage. The unit must be transported only in the working position.
- Avoid sharp blows, scratches, or rough handling during loading and unloading.
- Prior to the initial power-up after transportation at low temperatures, allow the unit to warm up at operating temperature for at least 3-4 hours.

## MANUFACTURER'S WARRANTY

The product is in compliance with EU norms and standards on low voltage guidelines and electromagnetic compatibility. We hereby declare that the product complies with the provisions of Electromagnetic Compatibility (EMC) Directive 2014/30/EU of the European Parliament and of the Council, Low Voltage Directive (LVD) 2014/35/EU of the European Parliament and of the Council and CE-marking Council Directive 93/68/EEC. This certificate is issued following test carried out on samples of the product referred to above.

The manufacturer hereby warrants normal operation of the unit for 24 months after the retail sale date provided the user's observance of the transportation, storage, installation, and operation regulations. Should any malfunctions occur in the course of the unit operation through the Manufacturer's fault during the guaranteed period of operation, the user is entitled to get all the faults eliminated by the manufacturer by means of warranty repair at the factory free of charge. The warranty repair includes work specific to elimination of faults in the unit operation to ensure its intended use by the user within the guaranteed period of operation. The faults are eliminated by means of replacement or repair of the unit components or a specific part of such unit component.

### The warranty repair does not include:

- routine technical maintenance
- unit installation/dismantling
- unit setup

To benefit from warranty repair, the user must provide the unit, the user's manual with the purchase date stamp, and the payment paperwork certifying the purchase. The unit model must comply with the one stated in the user's manual. Contact the Seller for warranty service.

### The manufacturer's warranty does not apply to the following cases:

- User's failure to submit the unit with the entire delivery package as stated in the user's manual including submission with missing component parts previously dismantled by the user.
- Mismatch of the unit model and the brand name with the information stated on the unit packaging and in the user's manual.
- User's failure to ensure timely technical maintenance of the unit.
- External damage to the unit casing (excluding external modifications as required for installation) and internal components caused by the user.
- Redesign or engineering changes to the unit.
- Replacement and use of any assemblies, parts and components not approved by the manufacturer.
- Unit misuse.
- Violation of the unit installation regulations by the user.
- Violation of the unit control regulations by the user.
- Unit connection to power mains with a voltage different from the one stated in the user's manual.
- Unit breakdown due to voltage surges in power mains.
- Discretionary repair of the unit by the user.
- Unit repair by any persons without the manufacturer's authorization.
- Expiration of the unit warranty period.
- Violation of the unit transportation regulations by the user.
- Violation of the unit storage regulations by the user.
- Wrongful actions against the unit committed by third parties.
- Unit breakdown due to circumstances of insuperable force (fire, flood, earthquake, war, hostilities of any kind, blockades).
- Missing seals if provided by the user's manual.
- Failure to submit the user's manual with the unit purchase date stamp.
- Missing payment paperwork certifying the unit purchase.



**FOLLOWING THE REGULATIONS STIPULATED HEREIN WILL ENSURE A LONG AND TROUBLE-FREE OPERATION OF THE UNIT**



**USER'S WARRANTY CLAIMS SHALL BE SUBJECT TO REVIEW ONLY UPON PRESENTATION OF THE UNIT, THE PAYMENT DOCUMENT AND THE USER'S MANUAL WITH THE PURCHASE DATE STAMP**







**CERTIFICATE OF ACCEPTANCE**

<b>Unit Type</b>	Single-room air handling unit with heat recovery
<b>Model</b>	
<b>Serial Number</b>	
<b>Manufacture Date</b>	
<b>Quality Inspector's Stamp</b>	

**SELLER INFORMATION**

<b>Seller</b>	
<b>Address</b>	
<b>Phone Number</b>	
<b>E-mail</b>	
<b>Purchase Date</b>	
This is to certify acceptance of the complete unit delivery with the user's manual. The warranty terms are acknowledged and accepted.	
<b>Customer's Signature</b>	

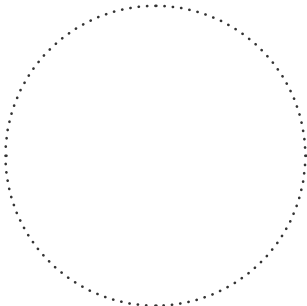

Seller's Stamp

**INSTALLATION CERTIFICATE**

The _____ unit is installed pursuant to the requirements stated in the present user's manual.	
<b>Company name</b>	
<b>Address</b>	
<b>Phone Number</b>	
<b>Installation Technician's Full Name</b>	
<b>Installation Date:</b>	<b>Signature:</b>
The unit has been installed in accordance with the provisions of all the applicable local and national construction, electrical and technical codes and standards. The unit operates normally as intended by the manufacturer.	
<b>Signature:</b>	

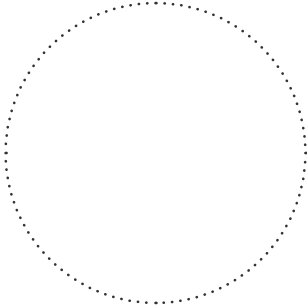

Installation Stamp

**WARRANTY CARD**

<b>Unit Type</b>	Single-room air handling unit with heat recovery
<b>Model</b>	
<b>Serial Number</b>	
<b>Manufacture Date</b>	
<b>Purchase Date</b>	
<b>Warranty Period</b>	
<b>Seller</b>	

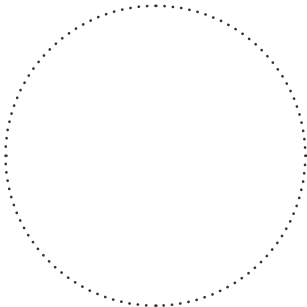

Seller's Stamp

