

Iso-RF EC

Sound-insulated inline centrifugal fans

Use

- Supply and exhaust ventilation systems in premises with high requirements to the noise level and with limited space for mounting.
- Possibility of space-restricted installation above suspended ceilings.
- Compatible with Ø 100–250 mm air ducts.



Air flow:
up to 1682 m³/h
467 l/s



Power:
from 118 W



Noise level:
from 33 dBA



Design

- The fan casing is made of aluzinc.
- For easy installation and operation, the top cover of the fan is secured with a special lock.
- Heat- and sound insulation is made of non-combustible 50 mm mineral wool layer. To ensure better noise absorption, the inner surface of the insulation is made of a perforated metal sheet.
- The round connecting spigots are rubber sealed.

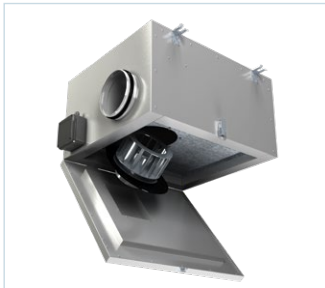

Speed control

- The fan speed is controlled with a 0–10 V control signal from the following sources:
 - integrated or external speed controller
 - controller with sensors
 - central BMS system.
- The control signal value changes depending on air temperature, pressure, smoke concentration and other parameters.
- During signal value change the fan with EC motor correspondingly changes the rotations speed and delivers required air volume to the ventilation system.
- The computer central building management systems (BMS) enable integration of several EC motors in network and precise individual operation control for each fan.

Mounting

- The fans are designed for connection to round air ducts. The fans are to be installed at an air duct junction.
- The use of flexible connectors requires fixation of the fan on the building structure by means of supports, mounts or fixing brackets.
- The fan can be fixed in any position with respect to the air flow direction indicated by the arrow on the fan casing. While mounting the fan provide enough access for servicing and repair operations.

Motor

- High-efficient direct current EC motor with external rotor and forward curved blades.
- EC technology meets the up-to-date requirements to energy-saving and controllable ventilation and provides up to 35 % energy saving as compared to asynchronous motors.
- EC motor ensures totally controllable speed range for the fan and has integrated overheating protection with automatic restart.
- EC motor has no friction and wearing parts as capacitor und brushes. Instead a maintenance-free EC controller electronic circuit board is used.
- The impeller is dynamically balanced.
- The fan is compatible with 50 Hz and 60 Hz power mains and the maximum speed does not depend on power mains frequency.

Designation key

Series	Motor	Duct diameter [mm]	Options
Iso-RF	EC: synchronous electronically commutated motor	100; 125; 150; 160; 200; 250	W1: power cable with mains plug

Accessories

Silencers	Filter boxes	Electric heaters	Water heaters	Backdraft air dampers	Air dampers	Speed controllers	Timers/Sensors
 SD	 KFBK / KFBT	 EKH	 WKH	 VRV	 VK / VKA	 CDT E/0-10	 TE(TI) / HSE(HSI) / LSE(LSI) / IRSE(IRSI)

Overall dimensions [mm]

Type	Ø D	B	B1	B2	H	L	L1	L2	Weight [kg]
Iso-RF EC 100	97	512	360	589	280	504	553	460	17
Iso-RF EC 125	122	512	360	589	280	504	553	460	17
Iso-RF EC 150	147	592	390	669	350	564	613	520	24
Iso-RF EC 160	157	592	390	669	350	564	613	520	24
Iso-RF EC 200	197	552	374	629	370	597	646	553	26
Iso-RF EC 250	247	665	487	742	405	650	699	606	33

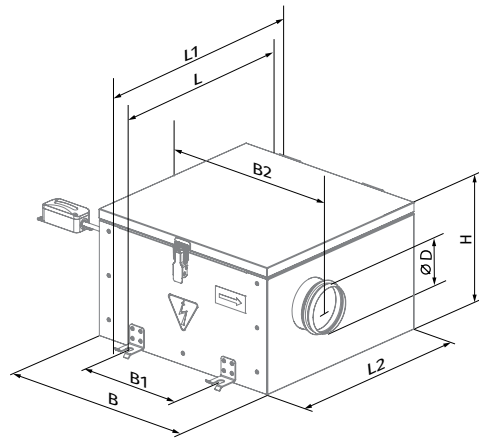

Technical data

Parameters	Iso-RF EC 100	Iso-RF EC 125	Iso-RF EC 150 Iso-RF EC 160
Voltage [V/50 (60) Hz]	1 ~ 230	1 ~ 230	1 ~ 230
Power [W]	118	118	220
Current [A]	0.92	0.92	0.59
Maximum air flow [m ³ /h (l/s)]	353 (98)	393 (109)	779 (216)
RPM [min ⁻¹]	3000	3000	2070
Sound pressure level at 3 m distance [dBA]	33	33	38
Transported air temperature [°C]	-25...+50	-25...+50	-25...+50
IP rating	IP44	IP44	IP44
Motor IP rating	IP54	IP54	IP54
SEC class	C	C	B
ErP	2018	2018	2018

ISO-RF EC 100

Sound power level, A-weighted	Total	Octave frequency bands [Hz]								LpA 3 m	LpA 1 m
		63	125	250	500	1000	2000	4000	8000		
L _{WA} to inlet [dBA]	69	61	61	64	60	58	58	56	52	48	58
L _{WA} to outlet [dBA]	73	55	65	67	67	63	65	60	56	52	62
L _{WA} to environment [dBA]	53	35	39	50	46	43	45	40	34	33	43

ISO-RF EC 125

Sound power level, A-weighted	Total	Octave frequency bands [Hz]								LpA 3 m	LpA 1 m
		63	125	250	500	1000	2000	4000	8000		
L _{WA} to inlet [dBA]	69	56	60	64	63	62	60	56	46	49	59
L _{WA} to outlet [dBA]	75	57	68	66	67	69	68	60	51	54	64
L _{WA} to environment [dBA]	54	17	35	43	44	50	49	41	30	33	43

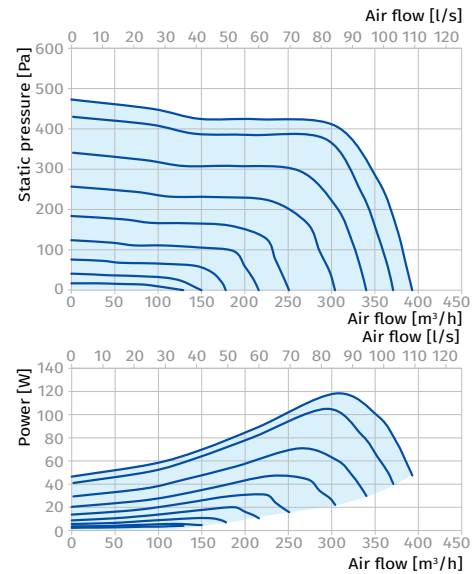
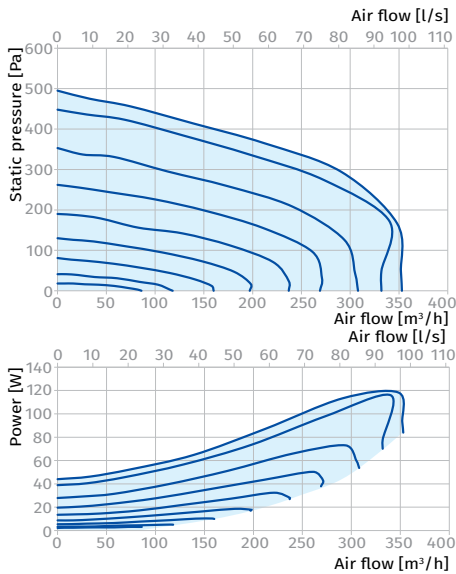

ISO-RF EC 150, ISO-RF EC 160

Sound power level, A-weighted	Total	Octave frequency bands [Hz]								LpA 3 m	LpA 1 m
		63	125	250	500	1000	2000	4000	8000		
L _{WA} to inlet [dBA]	76	62	71	70	68	66	64	62	56	55	65
L _{WA} to outlet [dBA]	80	60	71	74	73	72	68	60	59	59	69
L _{WA} to environment [dBA]	59	32	45	53	52	53	52	45	35	38	48

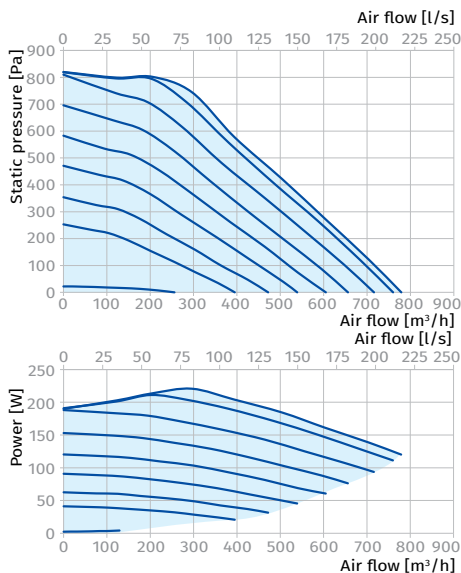

Parameters	Iso-RF EC 200	Iso-RF EC 250
Voltage [V/50 (60) Hz]	1 ~ 230	1 ~ 230
Power [W]	259	374
Current [A]	1.45	1.77
Maximum air flow [m³/h (l/s)]	1264 (351)	1682 (467)
RPM [min ⁻¹]	1600	1400
Sound pressure level at 3 m distance [dBA]	40	41
Transported air temperature [°C]	-25...+50	-25...+50
IP rating	IP44	IP44
Motor IP rating	IP54	IP54
SEC class	-	-
ErP	2018	2018

ISO-RF EC 200

Sound power level, A-weighted	Total	Octave frequency bands [Hz]								LpA 3 m	LpA 1 m
		63	125	250	500	1000	2000	4000	8000		
L _{WA} to inlet [dBA]	74	66	66	70	65	63	63	61	57	54	64
L _{WA} to outlet [dBA]	79	60	71	73	73	69	71	65	61	58	68
L _{WA} to environment [dBA]	60	40	45	58	53	49	52	46	39	40	50

ISO-RF EC 250

Sound power level, A-weighted	Total	Octave frequency bands [Hz]								LpA 3 m	LpA 1 m
		63	125	250	500	1000	2000	4000	8000		
L _{WA} to inlet [dBA]	79	65	75	74	71	69	67	65	59	59	69
L _{WA} to outlet [dBA]	83	62	74	77	76	75	75	71	62	62	72
L _{WA} to environment [dBA]	62	34	47	56	55	56	55	47	37	41	51

