



CENTRIFUGAL INLINE FAN



Iso Box-F(R)

EN

USER'S MANUAL

CONTENTS

Safety requirements.....	2
Purpose.....	4
Delivery set.....	4
Designation key.....	4
Technical data.....	5
Unit design and operating principle.....	8
Installation and set-up.....	9
Connection to power mains.....	10
Control.....	10
Technical maintenance.....	11
Troubleshooting.....	12
Storage and transportation regulations.....	12
Manufacturer's warranty.....	13
Certificate of acceptance.....	14
Seller information.....	14
Installation certificate.....	14
Warranty card.....	14

This user's manual is a main operating document intended for technical, maintenance, and operating staff.

The manual contains information about purpose, technical details, operating principle, design, and installation of the Iso Box-F(R) unit and all its modifications.

Technical and maintenance staff must have theoretical and practical training in the field of ventilation systems and should be able to work in accordance with workplace safety rules as well as construction norms and standards applicable in the territory of the country.

The information in this user's manual is correct at the time of the document's preparation.

The Company reserves the right to modify the technical characteristics, design, or configuration of its products at any time in order to incorporate the latest technological developments.

No part of this publication may be reproduced, stored in a retrieval system, or transmitted, in any form or by any means in any information search system or translated into any language in any form without the prior written permission of the Company.

SAFETY REQUIREMENTS

- Please read the user's manual carefully prior to installing and operating the unit.
- All user's manual requirements as well as the provisions of all the applicable local and national construction, electrical, and technical norms and standards must be observed when installing and operating the unit.
- The warnings contained in the user's manual must be considered most seriously since they contain vital personal safety information.
- Failure to follow the rules and safety precautions noted in this user's manual may result in an injury or unit damage.
- After a careful reading of the manual, keep it for the entire service life of the unit.
- While transferring the unit control, the user's manual must be turned over to the receiving operator.

UNIT INSTALLATION AND OPERATION SAFETY PRECAUTIONS



- Disconnect the unit from power mains prior to any installation operations.



- Unpack the unit with care.



- The unit must be grounded!



- While installing the unit, follow the safety regulations specific to the use of electric tools.



- Do not change the power cable length at your own discretion. Do not bend the power cable. Avoid damaging the power cable. Do not put any foreign objects on the power cable.

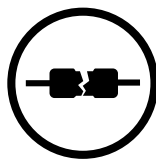

- Do not use damaged equipment or cables when connecting the unit to power mains.



- Do not touch the unit controls with wet hands. Do not carry out the installation and maintenance operations with wet hands.



- Do not allow children to operate the unit.



- Do not store any explosive or highly flammable substances in close proximity to the unit.

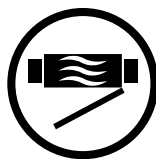

- Do not open the unit during operation.



- Do not block the air duct when the unit is switched on.

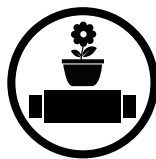

- Do not sit on the unit and avoid placing foreign objects on it.



- Do not lay the power cable of the unit in close proximity to heating equipment.

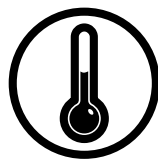

- Do not operate the unit outside the temperature range stated in the user's manual. Do not operate the unit in aggressive or explosive environments.



- Do not wash the unit with water. Protect the electric parts of the unit against ingress of water.

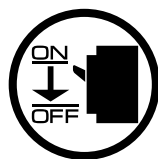

- Disconnect the unit from power mains prior to any technical maintenance.



- When the unit generates unusual sounds, odour, or emits smoke, disconnect it from power supply and contact the Seller.



- Do not direct the air flow produced by the unit towards open flame or ignition sources.



- In case of continuous operation of the unit, periodically check the security of mounting.

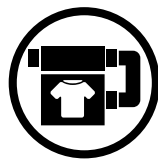

- Use the unit only for its intended purpose.



**THE PRODUCT MUST BE DISPOSED SEPARATELY AT THE END OF ITS SERVICE LIFE.
DO NOT DISPOSE THE UNIT AS UNSORTED MUNICIPAL WASTE.**

PURPOSE



THE UNIT SHOULD NOT BE OPERATED BY CHILDREN OR PERSONS WITH REDUCED PHYSICAL, MENTAL, OR SENSORY CAPACITIES, OR THOSE WITHOUT THE APPROPRIATE TRAINING. THE UNIT MUST BE INSTALLED AND CONNECTED ONLY BY PROPERLY QUALIFIED PERSONNEL AFTER THE APPROPRIATE BRIEFING.

THE CHOICE OF UNIT INSTALLATION LOCATION MUST PREVENT UNAUTHORIZED ACCESS BY UNATTENDED CHILDREN.

The centrifugal fan in a sound insulated casing is designed for supply and exhaust ventilation of domestic, public and industrial premises with high requirements to the noise level and with limited space for mounting.

The unit is rated for continuous operation.

The unit is a component part and is not designed for stand-alone operation.

Transported air must not contain any flammable or explosive mixtures, evaporation of chemicals, sticky substances, fibrous materials, coarse dust, soot and oil particles or environments favourable for the formation of hazardous substances (toxic substances, dust, pathogenic germs).

DELIVERY SET

NAME	NUMBER
Fan	1 pc.
User's manual	1 pc.
Packing box	1 pc.

DESIGNATION KEY

Designation example: **Iso Box-F 150 G4/F8 V2 W1**

Series	
Iso Box-R — centrifugal fan without filters	
Iso Box-F — centrifugal fan with filters	
Spigot connecting diameter [mm]	
100; 150; 200	
Filter	
ES — electrostatic filter	
G4; G4/F8; G4/F8/Carbon; G4/H13; G4/H13/Carbon	
Electric motor	
V2 — double-speed motor	
L — low noise and low-powered motor	
Connection	
W — power cord with a C14 connector	
W1 — power cord with an electric plug	

TECHNICAL DATA

The unit is designed for indoor application with the ambient temperature ranging from -25 °C to +40 °C and relative humidity up to 80 %. Ingress protection rating against access to hazardous parts and water ingress is IPX4. The unit design is constantly being improved, thus some models may be slightly different from those described in this manual.

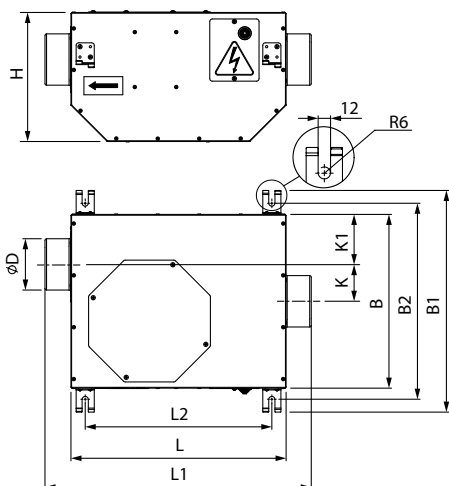

Iso Box-R (V2) OVERALL DIMENSIONS [mm]

Model	D	L	H	B	L1	B1	L2	B2	K	K1
Iso Box-R 100 (V2)	100	415	250	335	515	428	360	378	70	97
Iso Box-R 150 (V2) L	150	415	250	335	515	428	360	378	70	97
Iso Box-R 150 (V2)	150	450	300	395	550	488	395	438	70	127
Iso Box-R 200 (V2)	200	450	300	395	550	488	395	438	70	127

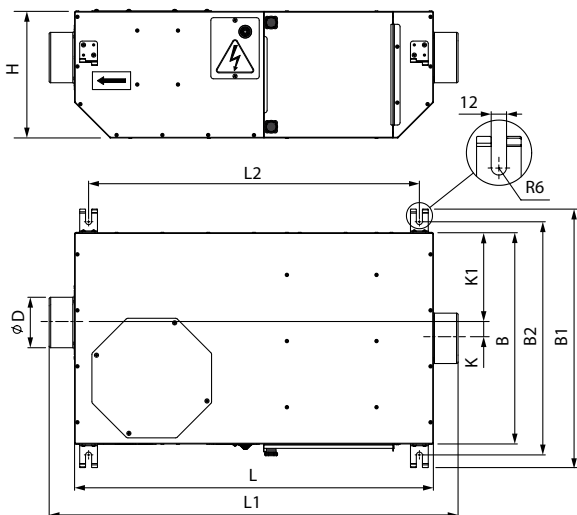

Iso Box-F (V2) OVERALL DIMENSIONS [mm]

Model	D	L	H	B	L1	B1	L2	B2	K	K1
Iso Box-F 100 (V2)	100	705	250	415	805	508	650	458	31	177
Iso Box-F 150 (V2) L	150	705	250	415	805	508	650	458	31	177
Iso Box-F 150 (V2)	150	735	300	440	835	533	680	483	47	173
Iso Box-F 200 (V2)	200	735	300	605	835	698	680	648	35	267

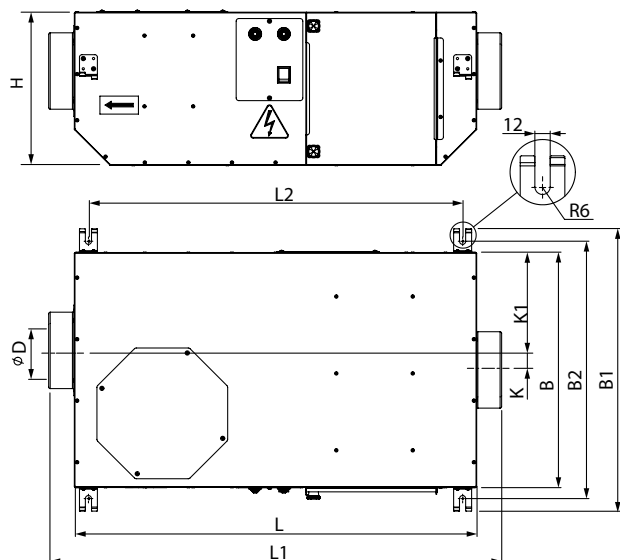

Iso Box-F (V2) ES OVERALL DIMENSIONS [mm]

Model	D	L	H	B	LI	B1	L2	B2	K	K1
Iso Box-F 100 (V2) ES	100	755	250	458	855	551	700	502	10	219
Iso Box-F 150 (V2) LES	150	755	250	458	855	551	700	502	10	219
Iso Box-F 150 (V2) ES	150	785	300	458	885	551	730	502	38	191
Iso Box-F 200 (V2) ES	200	785	300	658	885	751	730	702	62	391

TECHNICAL DATA OF THE Iso Box-R UNIT

Parameters	Iso Box-R 100	Iso Box-R 150 L	Iso Box-R 150	Iso Box-R 200
Voltage [V/Hz]	1 ~ 230/50			
Power [W]	61	75	103	130
Current [A]	0.27	0.33	0.48	0.58
Maximum air flow [m³/h]	180	300	450	600
RPM [min⁻¹]	1200	1200	1200	1200
Sound pressure level at 3 m distance [dBA]	23	25	27	38
Maximum transported air temperature [°C]	-25...+40			
Ingress protection rating of the casing	IPX4			
SEC class	E	D	E	D

TECHNICAL DATA OF THE Iso Box-R V2 UNIT

Parameters	Iso Box-R 100 V2		Iso Box-R 150 V2		Iso Box-R 150 V2		Iso Box-R 200 V2	
	1	2	1	2	1	2	1	2
Speed	1	2	1	2	1	2	1	2
Voltage [V/Hz]	1 ~ 230/50							
Power [W]	36	43	46	54	92	119	107	137
Current [A]	0.15	0.2	0.2	0.25	0.4	0.55	0.47	0.62
Maximum air flow [m³/h]	170	200	220	360	350	450	370	600
RPM [min⁻¹]	700	1200	700	1200	700	1200	700	1200
Sound pressure level at 3 m distance [dBA]	14	23	15	25	16	27	22	38
Maximum transported air temperature [°C]	-25...+40							
Ingress protection rating of the casing	IPX4							
SEC class	C		C		C		C	

TECHNICAL DATA OF THE ISO BOX-F UNIT

Parameters	Iso Box-F 100		Iso Box-F 100 G4		Iso Box-F 100 G4/F8		Iso Box-F 100 G4/H13		Iso Box-F 150 L		Iso Box-F 150 G4 L		Iso Box-F 150 G4/F8 L		Iso Box-F 150 G4/H13 L		Iso Box-F 150		Iso Box-F 150 G4		Iso Box-F 150 G4/F8		Iso Box-F 150 G4/H13		Iso Box-F 200		Iso Box-F 200 G4		Iso Box-F 200 G4/F8		Iso Box-F 200 G4/H13	
	1	2	1	2	1	2	1	2	1	2	1	2	1	2	1	2	1	2	1	2	1	2	1	2	1	2	1	2	1	2		
Voltage [V/Hz]	1 ~ 230/50																															
Power [W]	53	53	53	52	63	63	61	59	107	107	104	102	123	123	120	115																
Current [A]	0.27	0.27	0.27	0.27	0.29	0.29	0.25	0.28	0.49	0.49	0.48	0.48	0.56	0.56	0.56	0.52																
Maximum air flow [m³/h]	190	190	180	170	360	360	330	310	440	440	400	360	580	580	570	490																
RPM [min⁻¹]	1300	1300	1300	1300	1300	1300	1300	1300	1250	1250	1250	1250	1250	1250	1250	1250																
Sound pressure level at 3 m distance [dBA]	23	23	23	23	25	25	25	25	27	27	27	27	38	38	38	38																
Maximum transported air temperature [°C]	-25 ... +40																															
Ingress protection rating of the casing	IPX4																															
PM 2.5 removal efficiency [%]	36	36	93	98	31	31	92	98	39	39	92	98	40	40	93	98																
SEC class	C	C	C	C	C	C	C	C	C	C	C	C	D	C	C	C																

TECHNICAL DATA OF THE Iso Box-F V2 UNIT

Parameters	Iso Box-F 100 G4 V2		Iso Box-F 100 G4/F8 V2		Iso Box-F 100 G4/H13 V2		Iso Box-F 150 G4 V2 L		Iso Box-F 150 G4/F8 V2 L		Iso Box-F 150 G4/H13 V2 L		Iso Box-F 150 G4 V2		Iso Box-F 150 G4/F8 V2		Iso Box-F 150 G4/H13 V2		Iso Box-F 200 G4 V2		Iso Box-F 200 G4/F8 V2		Iso Box-F 200 G4/H13 V2			
	1	2	1	2	1	2	1	2	1	2	1	2	1	2	1	2	1	2	1	2	1	2	1	2	1	2
Speed	1 2																									
Voltage [V/Hz]	1 ~ 230/50																									
Power [W]	34	42	33	41	32	41	44	52	41	50	40	48	92	117	89	115	85	114	106	123	103	121	97	119		
Current [A]	0.15	0.19	0.15	0.19	0.15	0.19	0.19	0.23	0.18	0.22	0.18	0.21	0.41	0.55	0.41	0.55	0.38	0.54	0.47	0.59	0.45	0.57	0.43	0.55		
Maximum air flow [m³/h]	160	190	150	175	140	160	230	340	215	310	205	285	320	430	300	390	280	355	390	630	380	590	350	525		
RPM [min⁻¹]	700	1200	700	1200	700	1200	700	1200	700	1200	700	1200	700	1200	700	1200	700	1200	700	1200	700	1200	700	1200		
Sound pressure level at 3 m distance [dBA]	14	23	14	23	14	23	15	25	15	25	15	25	16	27	16	27	16	27	22	38	22	38	22	38		
Maximum transported air temperature [°C]	-25...+40																									
Ingress protection rating of the casing	IPX4																									
PM 2.5 removal efficiency [%]	35	31	94	93	99	98	31	23	90	87	93	92	47	41	95	94	98	96	37	28	98	97	99	98		
SEC class	C		C		D		C		C		C		D		D		E		C		D		D			

TECHNICAL DATA OF THE Iso Box-F V2 ES UNIT

Parameters	Iso Box-F 100 V2 ES		Iso Box-F 150 V2 L ES		Iso Box-F 150 V2 ES		Iso Box-F 200 V2 ES	
	1	2	1	2	1	2	1	2
Speed	1 2							
Voltage [V/Hz]	1 ~ 230/50							
Power [W]	34	42	44	52	92	117	106	123
Current [A]	0.15	0.19	0.19	0.23	0.41	0.55	0.47	0.59
Maximum air flow [m³/h]	160	190	230	340	320	430	390	630
RPM [min⁻¹]	700	1200	700	1200	700	1200	700	1200
Sound pressure level at 3 m distance [dBA]	14	23	15	25	16	27	22	38
Maximum transported air temperature [°C]	-25...+40							
Ingress protection rating of the casing	IPX4							
PM 2.5 removal efficiency [%]	98	97	98	97	97	96	98	97
SEC class	C		C		D		C	

UNIT DESIGN AND OPERATING PRINCIPLE

The unit is a centrifugal inline fan in a sound-insulated casing. The fan casing is made of painted sheet steel using heat- and sound-insulation material. The round connecting spigots are rubber sealed.

The fan is equipped with a two-pole AC motor with an external rotor and an impeller with backward curved blades. The motor has an integrated overheating protection with an automatic restart. Use of the motor with ball bearings with specially selected grease ensures low-noise, maintenance-free operation of the fan.

The Box-F fans are equipped with filters of different filtering classes. Each fan enables installing up to three filters of different intake air filtration classes (from rough to fine filtering).

The air flow direction is indicated by the arrow on the fan casing.

The Iso Box-F ES fans are equipped with an electrostatic filter that provides cleaning of air from fine dust, aerosols, smoke, soot particles and soot. Electrostatic filters rely on gravity of oppositely charged objects. Polluted air flows through the spray charging unit where particles become ionized. Then ionized particles are moved by the air stream and settle on the collecting plates which are oppositely charged.

Iso Box-R (V2)

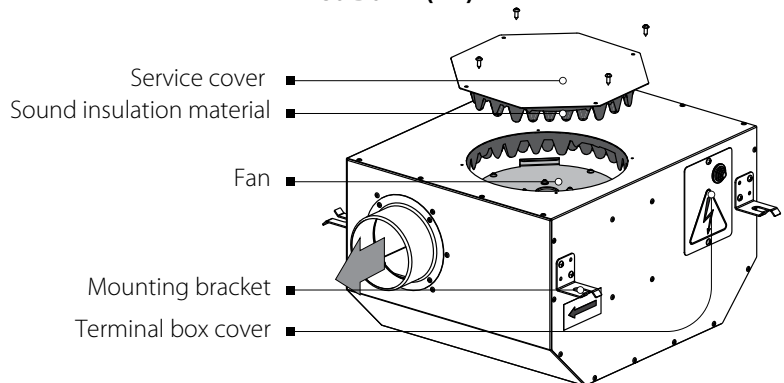

Iso Box-F (V2)

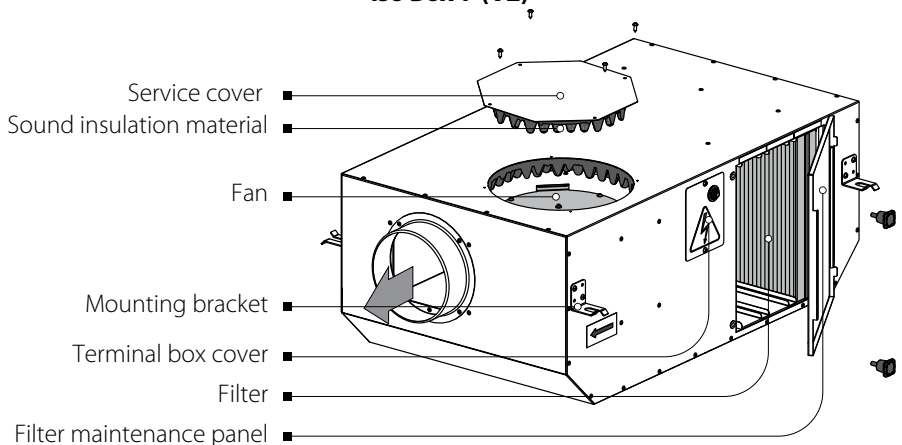

Iso Box-F (V2) ES

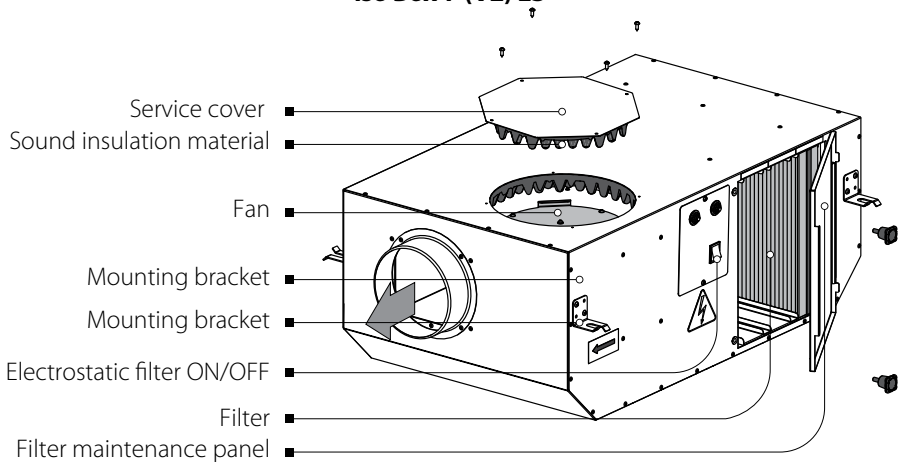

INSTALLATION AND SET-UP

The fan is suspended to the mounting surface through the threaded rod fixed inside the expansion anchor.

The fan is intended for mounting to round air ducts and is installed between them.

The casing is equipped with fixing brackets for easier installation of the fan. While installing the unit, ensure convenient access for subsequent maintenance and repair. Fasteners for ceiling mounting are not included in the delivery set and should be ordered separately. While choosing fasteners consider the material of the mounting surface as well as the weigh of the unit (refer to the «Technical data» section). Fasteners for unit mounting should be selected by the service technician.

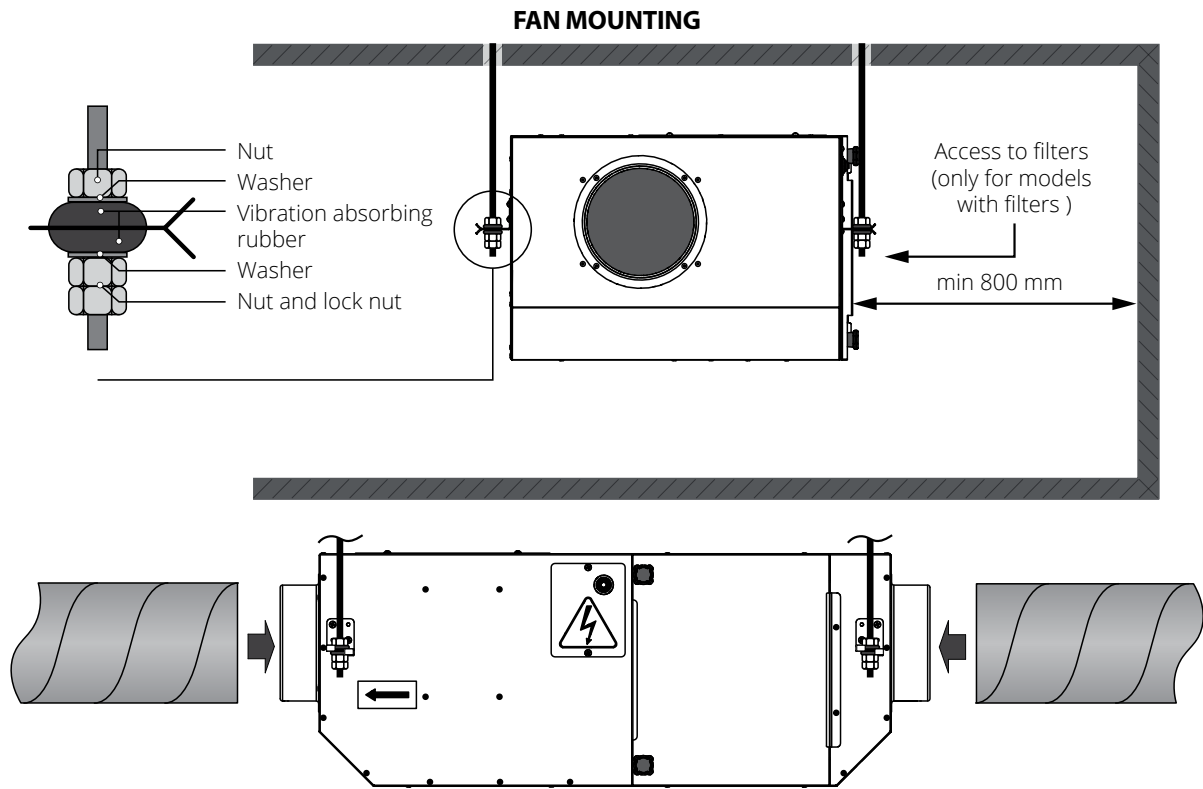

To get the best performance of the fan and to minimize turbulence-induced air pressure losses, connect the straight air duct section to the spigots on both sides of the unit while installing.

Minimum straight air duct length:

- equal to 1 air duct diameter on the intake side
- equal to 3 air duct diameters on the outlet side

If the air ducts are too short or not connected, protect the unit parts from ingress of foreign objects. To prevent uncontrollable access to the fans, the spigots may be covered with a protecting grille or other protecting device with mesh width not more than 12.5 mm.

CONNECTION TO POWER MAINS



DISCONNECT THE POWER SUPPLY PRIOR TO ANY OPERATIONS WITH THE UNIT.
CONNECTION OF THE UNIT TO POWER MAINS IS ALLOWED BY A QUALIFIED ELECTRICIAN WITH A WORK PERMIT FOR THE ELECTRIC UNITS UP TO 1000 V AFTER CAREFUL READING OF THE PRESENT USER'S MANUAL. THE RATED ELECTRICAL PARAMETERS OF THE UNIT ARE GIVEN ON THE MANUFACTURER'S LABEL.
ANY TAMPERING WITH THE INTERNAL CONNECTIONS IS PROHIBITED AND WILL VOID THE WARRANTY.



ANY TAMPERING WITH THE INTERNAL CONNECTIONS IS PROHIBITED AND WILL VOID THE WARRANTY.

- The unit is rated for connection to 1~230 V/50 Hz power mains.
- The unit must be connected to power mains using insulated electric conductors (cables, wires). The actual wire cross section selection must be based on the maximum load current, maximum conductor temperature depending on the wire type, insulation, length and installation method.
- The external power input must be equipped with an automatic circuit breaker built into the stationary wiring to open the electric circuit in case of overload or short-circuit. The circuit breaker installation place must provide quick access for emergency shutdown of the unit. The trip current of the automatic circuit breaker **QF** must exceed the maximum current consumption of the unit (refer to the technical data table). The recommended trip current of the circuit breaker is the next current in the standard trip current row following the maximum current of the connected unit. The automatic circuit breaker is not included in the delivery set.

The recommended cross section of conductors (cables, wires) is 0.75 mm².

The recommended circuit breaker nominal current should be not less than 1 A.

WIRING DIAGRAMS

Iso Box-F(R)

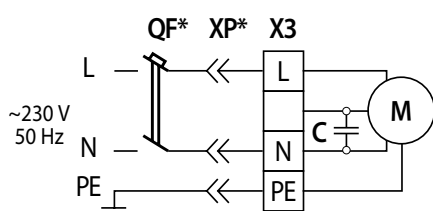

Iso Box-F(R) V2 Duo double-speed fan

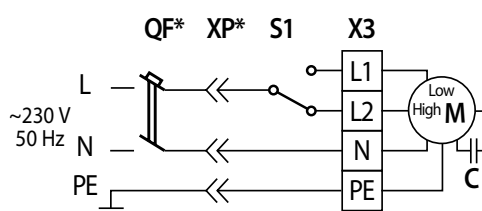

Electrostatic filter

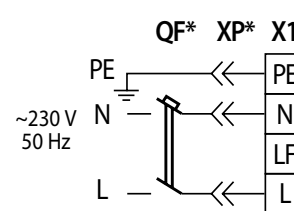

*Purchased separately.

CONTROL

The speed of the double-speed fan is switched (Low/High) at the stage of its connection to power mains according to the wiring diagram. The electrostatic filter is switched on/off by means of a switch on the fan casing.

TECHNICAL MAINTENANCE



DISCONNECT THE UNIT FROM POWER SUPPLY BEFORE ANY MAINTENANCE OPERATIONS!

Maintenance operations of the unit are required 3-4 times per year. They include regular cleaning of the unit and periodic cleaning of filters.

1. Filter maintenance.

Dirty filters increase air resistance in the system and reduce supply air volume.

The filters require cleaning not less than 3-4 times per year.

Vacuum cleaning is allowed.

After two consecutive cleanings filters must be replaced.

For new filters, contact the Seller.

Filter cleaning periodicity for electrostatic filters is from 7 to 21 days, determined by the user based on the results of a visual check of the filter.

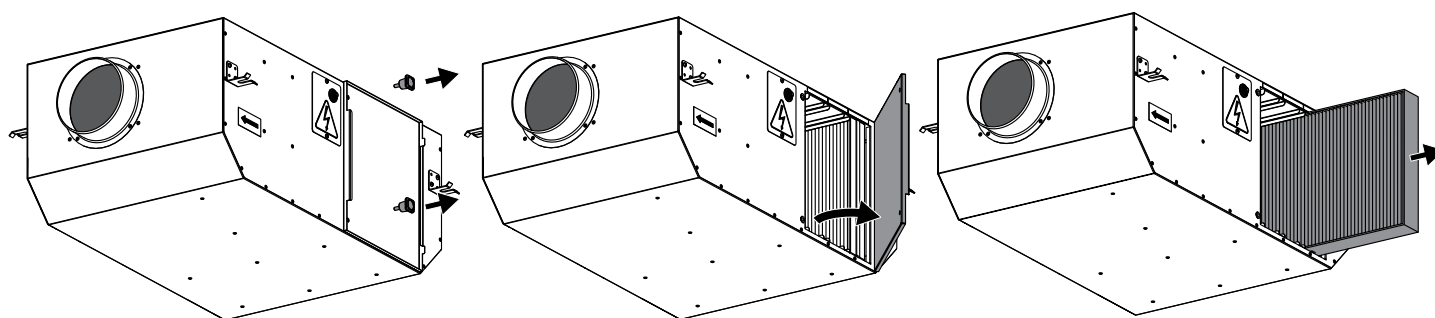

To replace/clean filters, follow these steps:

1. Unlatch the service panel.
2. Open the service panel.
3. Pull the filters to remove.
4. Clean the filters with a vacuum cleaner.
5. Assemble the unit in the reverse order.

2. Fan maintenance (once a year).

Even in case of regular maintenance of the filters, some dust may accumulate inside the fans and reduce the fan performance and supply air flow. Clean the fans with a soft brush or cloth. Do not use water, aggressive solvents, or sharp objects as they may damage the impeller.

3. Supply air flow control (twice per year).

The supply duct grille may get clogged with leaves and other objects reducing the unit performance and supply air delivery.

Check the supply grille twice per year and clean it as required.

4. Technical maintenance of air duct system (every 5 years).

Even regular fulfilling of all the prescribed above maintenance operations may not completely prevent dirt accumulation in the air ducts which reduces the unit capacity. Duct maintenance means regular cleaning or replacement.

TROUBLESHOOTING

PROBLEM	POSSIBLE REASONS	TROUBLESHOOTING
The fan(s) do(es) not get started.	No power supply.	Make sure the power supply line is connected correctly, otherwise troubleshoot a connection error.
	Jammed motor.	Turn off the fan. Troubleshoot the motor jamming. Restart the fan.
Automatic circuit breaker tripping following the fan turning on.	High current consumption due to short circuit in power line.	Turn off the fan. Contact the Seller.
Low air flow.	The filters and the fans are clogged, the heat exchanger is clogged.	Clean or replace the filters, clean the fans, and the heat exchanger.
	The ventilation system components (air ducts, diffusers, louvre shutters, grilles) are clogged or damaged.	Clean or replace the ventilation system components (air ducts, diffusers, louvre shutters, grilles).
Cold supply air.	Extract filter clogging.	Clean or replace the extract filter.
Noise, vibration.	The fan impeller is soiled.	Clean the impellers.
	The fan or casing screw connection is loose.	Tighten the screw connection of the fans or the casing all the way.

STORAGE AND TRANSPORTATION REGULATIONS

- Store the unit in the manufacturer's original packaging box in a dry closed ventilated premise with temperature range from +5 °C to +40 °C and relative humidity up to 70 %.
- Storage environment must not contain aggressive vapours and chemical mixtures provoking corrosion, insulation, and sealing deformation.
- Use suitable hoist machinery for handling and storage operations to prevent possible damage to the unit.
- Follow the handling requirements applicable for the particular type of cargo.
- The unit can be carried in the original packaging by any mode of transport provided proper protection against precipitation and mechanical damage. The unit must be transported only in the working position.
- Avoid sharp blows, scratches, or rough handling during loading and unloading.
- Prior to the initial power-up after transportation at low temperatures allow the unit to warm up at room temperature for at least 3-4 hours.

MANUFACTURER'S WARRANTY

The product is in compliance with EU norms and standards on low voltage guidelines and electromagnetic compatibility. We hereby declare that the product complies with the provisions of Electromagnetic Council Directive 2014/30/EU, Low Voltage Directive 2014/35/EU and CE-marking Directive 93/68/EEC. This certificate is issued following test carried out on samples of the product referred to above. The manufacturer hereby warrants normal operation of the unit for 24 months after the retail sale date provided the user's observance of the transportation, storage, installation, and operation regulations. Should any malfunctions occur in the course of the unit operation through the Manufacturer's fault during the guaranteed period of operation, the user is entitled to get all the faults eliminated by the manufacturer by means of warranty repair at the factory free of charge. The warranty repair includes work specific to elimination of faults in the unit operation to ensure its intended use by the user within the guaranteed period of operation. The faults are eliminated by means of replacement or repair of the unit components or a specific part of such unit component.

The warranty repair does not include:

- routine technical maintenance
- unit installation/dismantling
- unit setup

To benefit from warranty repair, the user must provide the unit, the user's manual with the purchase date stamp, and the payment paperwork certifying the purchase. The unit model must comply with the one stated in the user's manual. Contact the Seller for warranty service.

The manufacturer's warranty does not apply to the following cases:

- User's failure to submit the unit with the entire delivery package as stated in the user's manual including submission with missing component parts previously dismantled by the user.
- Mismatch of the unit model and the brand name with the information stated on the unit packaging and in the user's manual.
- User's failure to ensure timely technical maintenance of the unit.
- External damage to the unit casing (excluding external modifications as required for installation) and internal components caused by the user.
- Redesign or engineering changes to the unit.
- Replacement and use of any assemblies, parts and components not approved by the manufacturer.
- Unit misuse.
- Violation of the unit installation regulations by the user.
- Violation of the unit control regulations by the user.
- Unit connection to power mains with a voltage different from the one stated in the user's manual.
- Unit breakdown due to voltage surges in power mains.
- Discretionary repair of the unit by the user.
- Unit repair by any persons without the manufacturer's authorization.
- Expiration of the unit warranty period.
- Violation of the unit transportation regulations by the user.
- Violation of the unit storage regulations by the user.
- Wrongful actions against the unit committed by third parties.
- Unit breakdown due to circumstances of insuperable force (fire, flood, earthquake, war, hostilities of any kind, blockades).
- Missing seals if provided by the user's manual.
- Failure to submit the user's manual with the unit purchase date stamp.
- Missing payment paperwork certifying the unit purchase.



FOLLOWING THE REGULATIONS STIPULATED HEREIN WILL ENSURE A LONG AND TROUBLE-FREE OPERATION OF THE UNIT.



USER'S WARRANTY CLAIMS SHALL BE SUBJECT TO REVIEW ONLY UPON PRESENTATION OF THE UNIT, THE PAYMENT DOCUMENT AND THE USER'S MANUAL WITH THE PURCHASE DATE STAMP.

CERTIFICATE OF ACCEPTANCE

Unit Type	Centrifugal inline fan
Model	Iso Box-F(R) _____
Serial Number	
Manufacture Date	
Quality Inspector's Stamp	

SELLER INFORMATION

Seller	
Address	
Phone Number	
E-mail	
Purchase Date	
This is to certify acceptance of the complete unit delivery with the user's manual. The warranty terms are acknowledged and accepted.	
Customer's Signature	

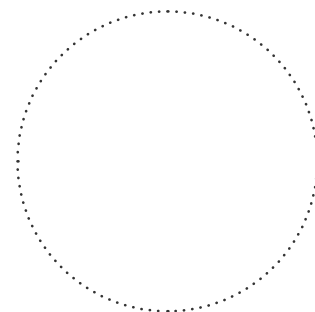

Seller's Stamp

INSTALLATION CERTIFICATE

The Iso Box-F(R) _____ unit has been connected to power mains pursuant to the requirements stated in the present user's manual.

Seller	
Address	
Phone Number	
Installation Technician's Full Name	
Installation Date:	Signature:
The unit has been installed in accordance with the provisions of all the applicable local and national construction, electrical and technical codes and standards. The unit operates normally as intended by the manufacturer.	
Signature:	

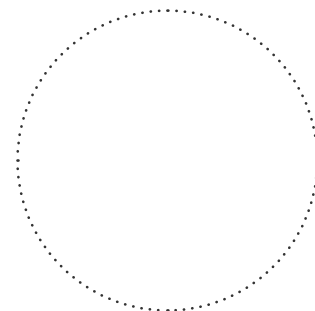

Installation Company Stamp

WARRANTY CARD

Unit Type	Centrifugal inline fan
Model	Iso Box-F(R) _____
Serial Number	
Manufacture Date	
Purchase Date	
Warranty Period	
Seller	

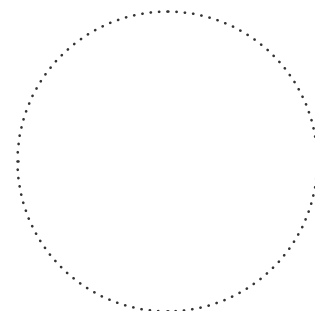

Seller's Stamp



BLAUBERG
Ventilatoren

