

Centro / Centro V2

Inline centrifugal fans

Use

- Supply and extract ventilation systems installed in various premises.
- Mounting in kitchens, bathrooms and other humid premises.
- Compatible with Ø 100 up to 315 mm round air ducts.



Air flow:
up to 1240 m³/h
344 l/s



Power:
from 62 W



Noise level:
from 40 dBA



Design

- High-quality durable plastic casing.
- Aerodynamically shaped casing.
- Airtight mounting box.
- Centro 150** is compatible with 150 and 160 mm air ducts.

Motor

- Single-phase external rotor motor with a centrifugal impeller with backward curved blades.
- Equipped with ball bearings for longer service life.
- Integrated thermal protection with automatic restart.
- Dynamically balanced impeller.
- Some standard sizes have high-powered motors (**Centro max**).
- Centro V2** is equipped with the two-speed asynchronous motor with external rotor and centrifugal dynamically balanced impeller with backward curved blades.

Speed control

- Smooth speed control with a built-in electronic speed controller (option **FR1**).
- Smooth speed control with an external thyristor controller or step speed control with an external auto transformer (both available upon separate order).
- Centro V2** series: two-speed control with the external **CDP-2/5** or **CDP-2/10** speed switch (available upon separate order).

Mounting

- Due to compact design the fan is the ideal solution for mounting in limited spaces.
- Any mounting position.
- Wall or ceiling mounting with fixing brackets supplied as a standard or with a wire frame **Halter Centro** (available upon separate order).
- Flexible air ducts are fixed on the fan spigots with clamps.



Modifications and options

- max:** high-powered motor.
- FR1:** smooth speed controller adjustable from 0 to 100 % and power cable with mains plug.



- G1:** speed controller, temperature controller with external temperature sensor (cable length 4 m), power cable with mains plug.
- G11:** speed controller, temperature controller with integrated temperature sensor and power cable with mains plug.
- The **G1** and **G11** modifications enable automatic speed control depending on indoor temperature. The optimal ventilation solution for premises requiring permanent temperature control as greenhouses, orangeries, etc.



- V:** built-in speed switch (for two-speed models).
- W1:** power cable with mains plug.

Accessories

Silencers	Filter boxes	Electric heaters	Water heaters	Backdraft air dampers	Air dampers	Clamps	Speed switches (only for Centro V2)	Speed controllers
SD	KFBK KFBT	EKH	WKH	VRV	VK / VKA	K	CDP-2/10 CDP-2/5	CDT1 E CDT E1.8

Designation key			
Series	Duct diameter [mm]	Motor modifications	Options
Centro	100; 125; 150*; 200; 250; 315	max: high-powered motor V2: two-speed motor	V: built-in speed switch (for two-speed models) FR1: smooth speed controller adjustable from 0 to 100 % and power cable with mains plug G1: speed controller, temperature controller with external temperature sensor, power cable with mains plug G11: speed controller, temperature controller with integrated temperature sensor and power cable mains plug W1: power cable with mains plug

* Centro 150 (V2) model is compatible with the air ducts both \varnothing 150 and 160 mm

Dimensions [mm]

Type	\varnothing D	\varnothing D1	B	L	L1	L2	L3	Weight [kg]
Centro 100 / Centro 100 V2	100	250	270	230	30	27	30	2.22
Centro 125 / Centro 125 V2	125	250	270	220	30	27	30	2.20
Centro 150 / Centro 150 V2	150/160	300	310	286	30	30	30	2.45
Centro 200 / Centro 200 max / Centro 200 V2	200	340	354	276	30	30	40	3.00
Centro 250 / Centro 250 V2	250	340	354	265	30	30	40	4.30
Centro 315 / Centro 315 V2	315	400	414	276	40	55	40	4.85

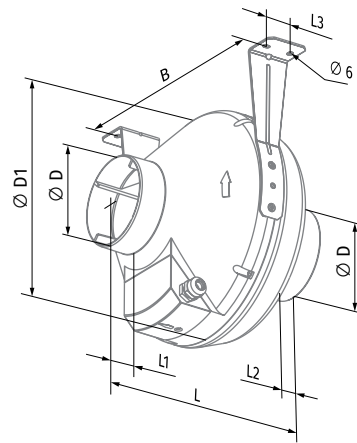

Technical data

Parameters	Centro 100		Centro 125		Centro 150		Centro 200		Centro 200 max	
Voltage [V]	1 ~ 230		1 ~ 230		1 ~ 230		1 ~ 230		1 ~ 230	
Frequency [Hz]	50	60	50	60	50	60	50	60	50	60
Power [W]	62	71	63	71	65	73	107	125	166	185
Current [A]	0.29	0.33	0.29	0.33	0.29	0.33	0.49	0.57	0.73	0.85
Maximum air flow [m³/h (l/s)]	250 (69)	270 (75)	340 (94)	350 (97)	460 (128)	505 (140)	780 (217)	785 (218)	1065 (296)	1000 (278)
RPM [min ⁻¹]	2769	3213	2751	3159	2628	2940	2616	2862	2700	2766
Sound pressure at 3 m [dBA]	40	41	40	41	42	43	46	46	48	49
Max. transported air temperature [°C]	-25...+55	-25...+50	-25...+55	-25...+50	-25...+55	-25...+50	-25...+55	-25...+50	-25...+55	-25...+45
SEC class	C	-	C	-	B	-	B	-	B	-
IP rating	IPX4		IPX4		IPX4		IPX4		IPX4	
Motor IP rating	IP44		IP44		IP44		IP44		IP44	
ErP	2018	-	2018	-	2018	-	2018	-	2018	-

To comply with ErP 2018 it is necessary to use a speed controller and local demand control typology (connect the sensor).

CENTRO 100

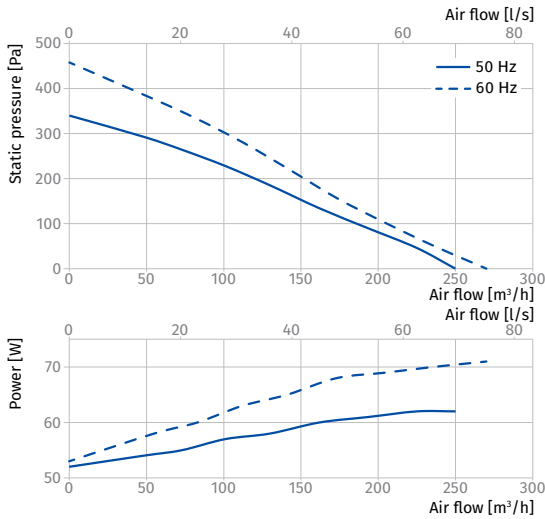

CENTRO 125

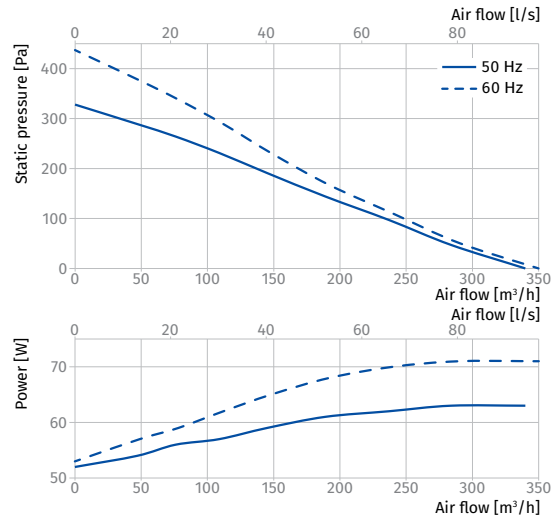

CENTRO 150

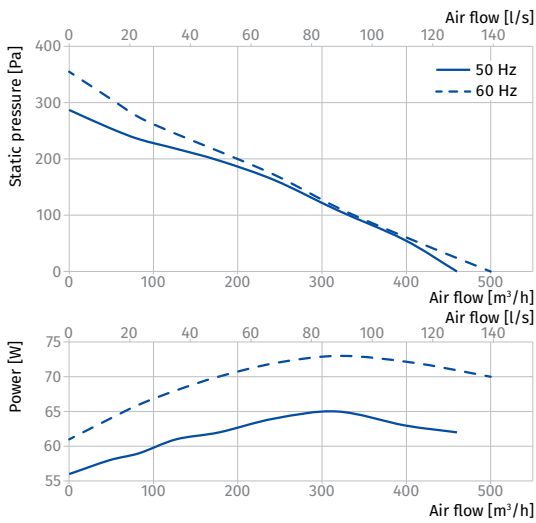

CENTRO 200, CENTRO 200 MAX

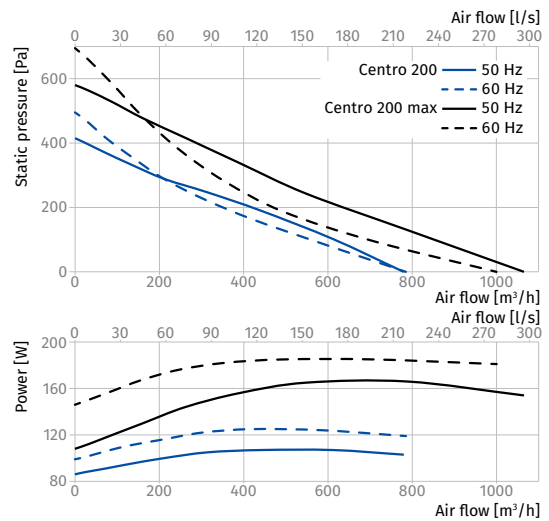

Parameters	Centro 250		Centro 315	
Voltage [V]	1 ~ 230		1 ~ 230	
Frequency [Hz]	50	60	50	60
Power [W]	171	188	169	187
Current [A]	0.75	0.86	0.74	0.86
Maximum air flow [m³/h (l/s)]	1100 (306)	1030 (286)	1240 (344)	1200 (333)
RPM [min ⁻¹]	2424	2746	2478	2590
Sound pressure at 3 m [dBA]	49	50	49	50
Max. transported air temperature [°C]	-25...+55	-25...+50	-25...+55	-25...+50
SEC class	B	-	B	-
IP rating	IPX4		IPX4	
Motor IP rating	IP44		IP44	
ErP	2018	-	2018	-

To comply with ErP 2018 it is necessary to use a speed controller and local demand control typology (connect the sensor).

CENTRO 250

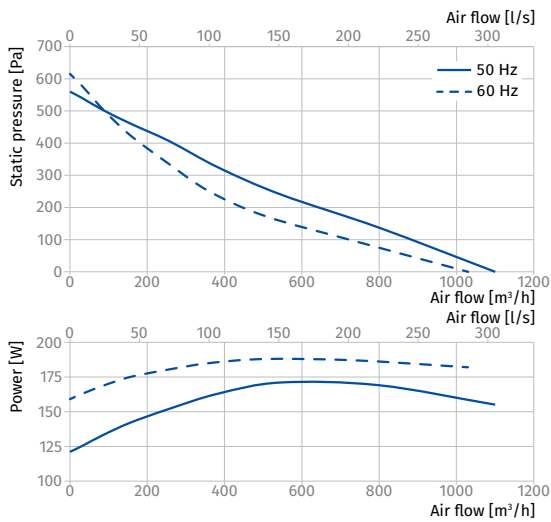

CENTRO 315

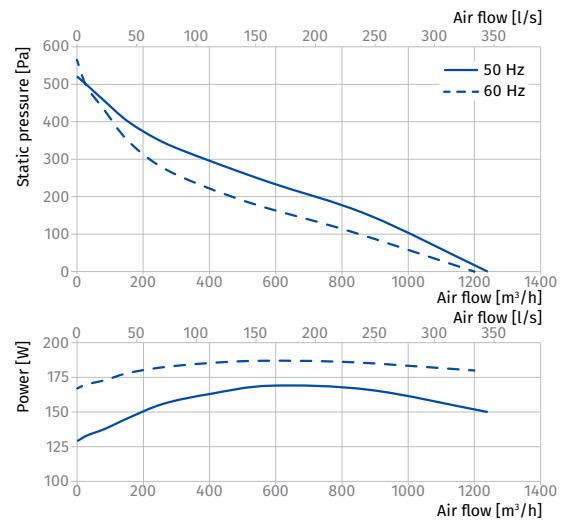

Parameters	Centro 100 V2		Centro 125 V2		Centro 150 V2		Centro 200 V2	
Speed	min	max	min	max	min	max	min	max
Voltage [V]	1 ~ 230		1 ~ 230		1 ~ 230		1 ~ 230	
Frequency [Hz]	50		50		50		50	
Power [W]	45	57	45	58	46	59	83	95
Current [A]	0.21	0.25	0.21	0.26	0.22	0.26	0.27	0.43
Maximum air flow [m ³ /h (l/s)]	157 (44)	264 (73)	191 (53)	329 (91)	264 (73)	445 (124)	430 (119)	741 (206)
RPM [min ⁻¹]	1820	2440	1810	2380	1805	2420	1920	2470
Sound pressure at 3 m [dBA]	38		39		40		42	
Transported air temperature [°C]	-25...+55		-25...+55		-25...+55		-25...+55	
SEC class	D		D		D		C	
IP rating	IPX4		IPX4		IPX4		IPX4	
Motor IP rating	IP44		IP44		IP44		IP44	
ErP	2018		2018		2018		2018	

CENTRO 100 V2

Sound power level, A-weighted	Total	Octave frequency bands [Hz]								LpA 3 m	LpA 1 m
		63	125	250	500	1000	2000	4000	8000		
LWA to inlet [dBA]	79	57	71	77	69	64	60	54	43	58	68
LWA to outlet [dBA]	79	64	72	77	69	61	57	53	42	58	68
LWA to environment [dBA]	58	27	46	48	53	54	50	41	32	38	48

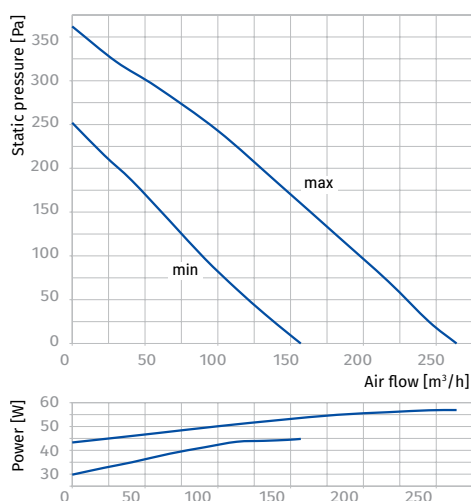

CENTRO 125 V2

Sound power level, A-weighted	Total	Octave frequency bands [Hz]								LpA 3 m	LpA 1 m
		63	125	250	500	1000	2000	4000	8000		
LWA to inlet [dBA]	81	59	74	79	72	66	62	56	45	61	71
LWA to outlet [dBA]	79	64	72	77	69	61	58	53	42	58	68
LWA to environment [dBA]	59	27	48	49	53	55	51	43	33	39	49

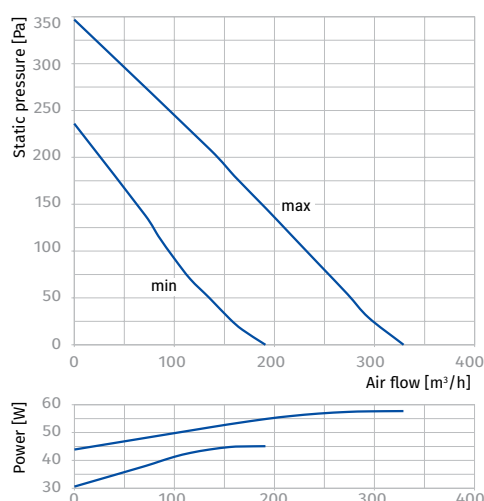

CENTRO 150 V2

Sound power level, A-weighted	Total	Octave frequency bands [Hz]								LpA 3 m	LpA 1 m
		63	125	250	500	1000	2000	4000	8000		
LWA to inlet [dBA]	88	52	85	84	74	73	70	67	53	67	77
LWA to outlet [dBA]	86	51	84	82	69	68	63	62	50	66	76
LWA to environment [dBA]	61	25	45	53	55	55	55	46	34	40	50

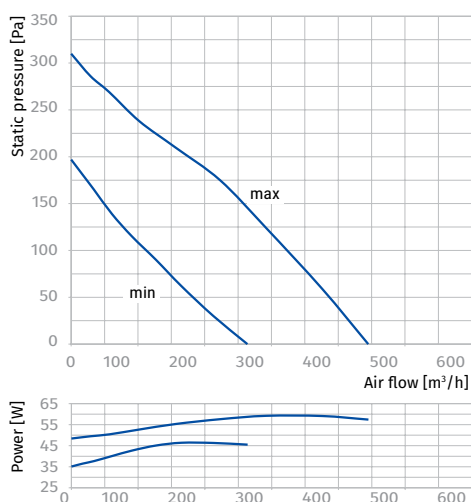

CENTRO 200 V2

Sound power level, A-weighted	Total	Octave frequency bands [Hz]								LpA 3 m	LpA 1 m
		63	125	250	500	1000	2000	4000	8000		
LWA to inlet [dBA]	81	45	70	77	73	73	74	67	56	61	71
LWA to outlet [dBA]	79	41	69	72	71	71	73	66	56	58	68
LWA to environment [dBA]	62	25	45	55	57	57	55	48	37	42	52

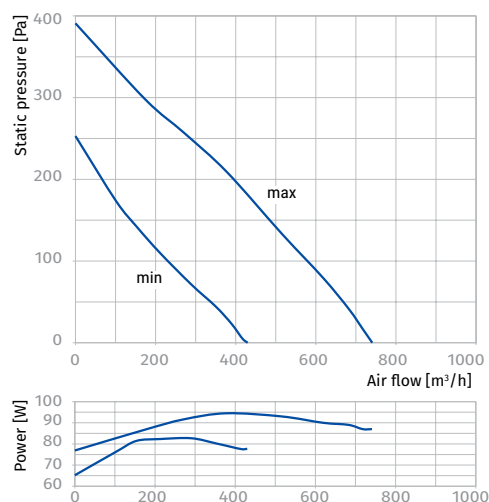

Parameters	Centro 250 V2		Centro 315 V2	
	min	max	min	max
Speed				
Voltage [V]	1 ~ 230		1 ~ 230	
Frequency [Hz]	50		50	
Power [W]	147	176	143	173
Current [A]	0.66	0.76	0.68	0.76
Maximum air flow [m³/h (l/s)]	642 (178)	1126 (313)	758 (211)	1268 (352)
RPM [min ⁻¹]	1940	2370	1870	2410
Sound pressure at 3 m [dBA]	46		48	
Transported air temperature [°C]	-25...+55		-25...+55	
SEC class	C		-	
IP rating	IPX4		IPX4	
Motor IP rating	IP44		IP44	
ErP	2018		-	

CENTRO 250 V2

Sound power level, A-weighted	Total	Octave frequency bands [Hz]								LpA 3 m	LpA 1 m
		63	125	250	500	1000	2000	4000	8000		
LWA to inlet [dBA]	86	51	73	71	75	81	82	77	67	66	76
LWA to outlet [dBA]	87	54	66	76	73	81	83	77	69	66	76
LWA to environment [dBA]	67	35	49	59	62	61	60	55	41	46	56

CENTRO 315 V2

Sound power level, A-weighted	Total	Octave frequency bands [Hz]								LpA 3 m	LpA 1 m
		63	125	250	500	1000	2000	4000	8000		
LWA to inlet [dBA]	90	54	77	75	79	85	86	81	71	70	80
LWA to outlet [dBA]	89	56	68	78	75	83	86	79	71	68	78
LWA to environment [dBA]	69	37	51	61	64	63	62	57	43	48	58

