

Box EC

Centrifugal fans with EC motor for rectangular ducts

Use

- Supply and extract ventilation systems installed in commercial, office and other public or industrial premises.
- For arranging energy-saving and controllable ventilation systems.
- Compatible with 300x150 up to 1000x500 mm rectangular air ducts.



Air flow:
up to 11190 m³/h
3109 l/s



Power:
from 91 W



Noise level:
from 43 dBA



Design

- Atmospheric resistant galvanized steel casing.
- The fan is rated for continuous operation always connected to power mains.
- Fitted with standard 20 mm connecting flanges for connection to rectangular air ducts.
- Access cover on the casing for inspection and maintenance operations.

Motor

- High-efficient direct current EC motor with external rotor and backward curved blades.
- EC technology meets the up-to-date requirements to energy-saving and controllable ventilation and provides up to 35 % energy saving as compared to asynchronous motors.
- EC motor ensures totally controllable speed range for the fan and has integrated overheating protection with automatic restart.
- EC motor has no friction and wearing parts as capacitor and brushes. Instead a maintenance-free EC controller electronic circuit board is used.
- The impeller is dynamically balanced.
- The fan is compatible with 50 Hz and 60 Hz power mains and the maximum speed does not depend on power mains frequency.

Speed control

- The fan speed is controlled with a 0-10 V control signal from the following sources:
 - integrated or external speed controller
 - controller with sensors
 - central BMS system.
- The control signal value changes depending on air temperature, pressure, smoke concentration and other parameters.
- During signal value change the fan with EC motor correspondingly changes the rotations speed and delivers required air volume to the ventilation system.
- The computer central building management systems (BMS) enable integration of several EC motors in network and precise individual operation control for each fan.

Mounting

- The fan is designed for mounting inside rectangular air ducts and can be installed in any position.
- The fan flanges are connected to the air ducts through the bolts inserted into the flange holes.
- Suitable for mounting into round duct on intake flange with a round flange reducer (available upon separate order).
- If flexible vibration-absorbing connectors are used to connect the fan to the air ducts provide their fixation to mounting structures with supports or brackets.
- While mounting provide enough space for accessing the cover for service operations.

INLINE FANS FOR RECTANGULAR DUCTS

Designation key

Series	Motor type	Flange size (width x height) [cm]	Phase	Motor modifications
Box	EC: electronically commutated motor	30x15; 40x20; 50x25; 50x30; 60x30; 60x35; 70x40; 80x50; 90x50; 100x50	- 1: single-phase 3: three-phase	-: standard type max: high-powered motor

Accessories

Silencers	Filter boxes	Electric heaters	Water heaters	Air dampers	Gravity dampers	Flexible antivibration connectors	Speed controllers
							
SD	KFBK / KFBT	EKH	WKH	SL	VG	EVA	CDT E/0-10

Overall dimensions [mm]

Type	H	H1	H2	H3	L	W	W1	W2	Weight [kg]
Box EC 30x15-1	150	170	190	228	350	300	320	340	5.5
Box EC 30x15-1 max	150	170	190	228	350	300	320	340	6.0
Box EC 40x20-1	200	220	240	278	440	400	420	440	8.3
Box EC 40x20-1 max	200	220	240	278	440	400	420	440	10.0
Box EC 50x25-1	250	270	290	328	530	500	520	540	15.7
Box EC 50x25-1 max	250	270	290	328	530	500	520	540	17.9
Box EC 50x30-1 max	300	320	340	410	530	500	520	540	18.7
Box EC 60x30-1	300	320	340	407	650	600	620	640	24.1
Box EC 60x30-1 max	300	320	340	370	680	600	620	640	26.5
Box EC 60x35-1	350	370	390	457	650	600	620	640	25.2
Box EC 60x35-3 max	350	370	390	512	650	600	620	640	36.0
Box EC 70x40-1	400	420	440	496	750	700	720	740	42.2
Box EC 70x40-3 max	400	420	440	555	750	700	720	740	43.0
Box EC 80x50-3	500	520	540	614	850	800	820	840	62.3
Box EC 80x50-3 max	500	520	540	670	850	800	820	840	54.3
Box EC 90x50-3 max	500	520	540	656	950	900	920	940	72.0
Box EC 100x50-3 max	500	520	540	656	950	1000	1020	1040	77.0

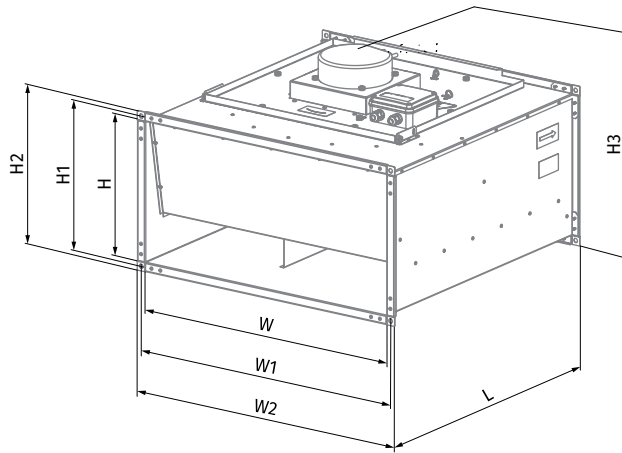

Parameters	Box EC 30x15-1	Box EC 30x15-1 max	Box EC 40x20-1	Box EC 40x20-1 max
Voltage [V / 50 (60) Hz]	1 ~ 230	1 ~ 230	1 ~ 230	1 ~ 230
Power [W]	97	101	91	192
Current [A]	0.73	0.80	0.69	1.43
Maximum air flow [m³/h (l/s)]	565 (157)	665 (185)	810 (225)	1190 (331)
RPM [min ⁻¹]	3300	3500	2470	3010
Sound pressure at 3 m [dBA]	44	46	43	47
Transported air temperature [°C]	-25...+50	-25...+50	-25...+50	-25...+50
SEC class	B	B	B	-
IP rating	IPX4	IPX4	IPX4	IPX4
Motor IP rating	IP55	IP54	IP55	IP54
ErP	2018	2018	2018	2018

BOX EC 30x15-1

Sound power level, A-weighted	Total	Octave frequency bands [Hz]								LpA 3 m	LpA 1 m
		63	125	250	500	1000	2000	4000	8000		
LWA to inlet [dBA]	75	53	63	69	72	63	62	63	55	54	64
LWA to outlet [dBA]	78	57	63	70	73	69	71	68	60	57	67
LWA to environment [dBA]	64	35	51	53	62	58	54	48	40	44	54

BOX EC 30x15-1 MAX

Sound power level, A-weighted	Total	Octave frequency bands [Hz]								LpA 3 m	LpA 1 m
		63	125	250	500	1000	2000	4000	8000		
LWA to inlet [dBA]	76	54	64	70	73	64	63	64	56	56	66
LWA to outlet [dBA]	80	59	65	73	75	72	74	71	62	60	70
LWA to environment [dBA]	67	37	53	55	64	60	56	50	42	46	56

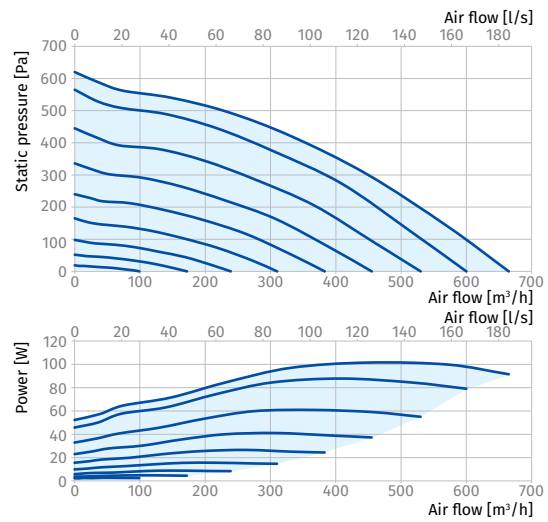
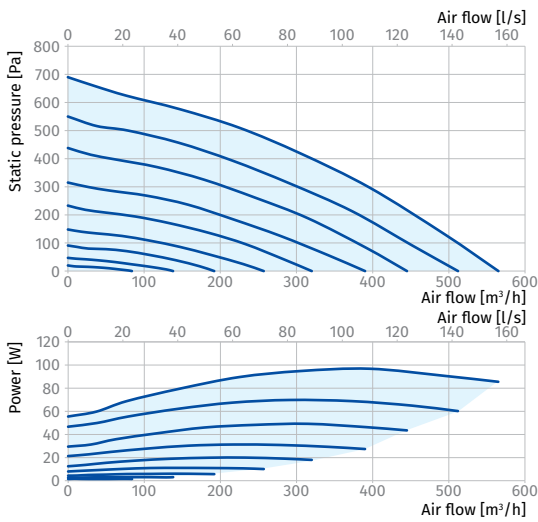

BOX EC 40x20-1

Sound power level, A-weighted	Total	Octave frequency bands [Hz]								LpA 3 m	LpA 1 m
		63	125	250	500	1000	2000	4000	8000		
LWA to inlet [dBA]	76	40	55	72	65	69	67	65	60	55	65
LWA to outlet [dBA]	78	37	52	70	71	69	73	68	61	57	67
LWA to environment [dBA]	63	39	47	61	57	52	51	46	39	43	53

BOX EC 40x20-1 MAX

Sound power level, A-weighted	Total	Octave frequency bands [Hz]								LpA 3 m	LpA 1 m
		63	125	250	500	1000	2000	4000	8000		
LWA to inlet [dBA]	83	50	79	75	76	76	72	66	65	62	72
LWA to outlet [dBA]	82	47	75	74	76	77	69	63	60	61	71
LWA to environment [dBA]	68	48	65	61	58	58	51	44	40	47	57

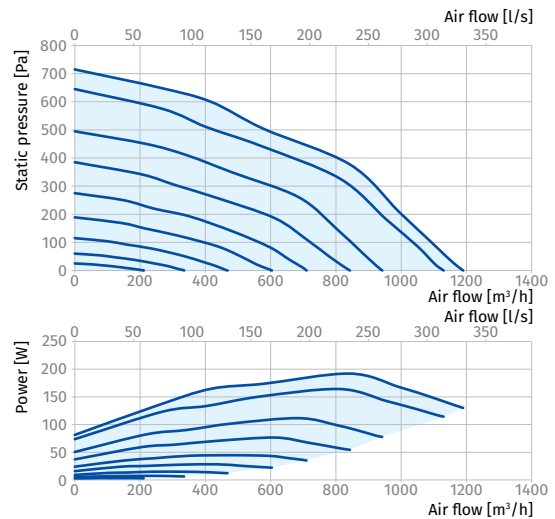
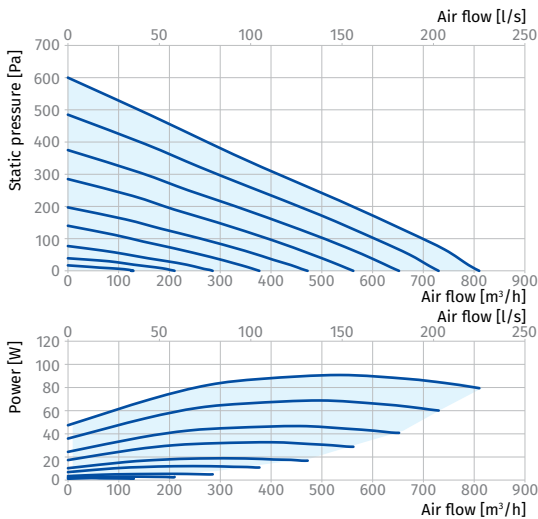

Parameters	Box EC 50x25-1	Box EC 50x25-1 max	Box EC 50x30-1 max	Box EC 60x30-1
Voltage [V/50 (60) Hz]	1 ~ 230	1 ~ 230	1 ~ 230	1 ~ 230
Power [W]	252	555	553	326
Current [A]	1.85	4.10	4.20	2.45
Maximum air flow [m³/h (l/s)]	1590 (442)	2480 (689)	2700 (750)	2545 (707)
RPM [min⁻¹]	2500	3100	3100	2000
Sound pressure at 3 m [dBA]	45	51	51	48
Transported air temperature [°C]	-25...+50	-25...+50	-25...+50	-25...+50
SEC class	-	-	-	-
IP rating	IPX4	IPX4	IPX4	IPX4
Motor IP rating	IP54	IP54	IP54	IP54
ErP	2018	2018	2018	2018

BOX EC 50x25-1

Sound power level, A-weighted	Total	Octave frequency bands [Hz]								LpA 3 m	LpA 1 m
		63	125	250	500	1000	2000	4000	8000		
LWA to inlet [dBA]	78	41	57	75	67	71	69	67	62	57	67
LWA to outlet [dBA]	80	38	54	72	73	71	75	70	63	59	69
LWA to environment [dBA]	65	40	48	63	59	54	53	47	40	45	55

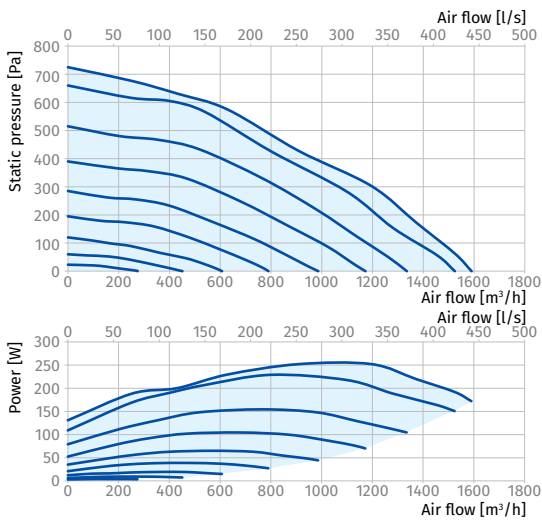

BOX EC 50x25-1 MAX

Sound power level, A-weighted	Total	Octave frequency bands [Hz]								LpA 3 m	LpA 1 m
		63	125	250	500	1000	2000	4000	8000		
LWA to inlet [dBA]	86	53	82	78	79	79	75	69	68	66	76
LWA to outlet [dBA]	85	48	78	77	79	80	72	66	63	64	74
LWA to environment [dBA]	72	50	69	65	62	62	55	46	42	51	61

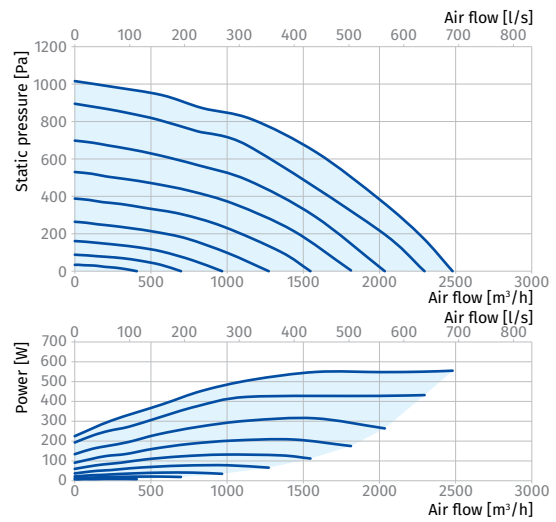

BOX EC 50x30-1 MAX

Sound power level, A-weighted	Total	Octave frequency bands [Hz]								LpA 3 m	LpA 1 m
		63	125	250	500	1000	2000	4000	8000		
LWA to inlet [dBA]	85	50	80	78	78	78	75	69	67	65	75
LWA to outlet [dBA]	85	48	79	76	78	79	72	66	62	64	74
LWA to environment [dBA]	72	49	70	65	60	60	54	46	40	51	61

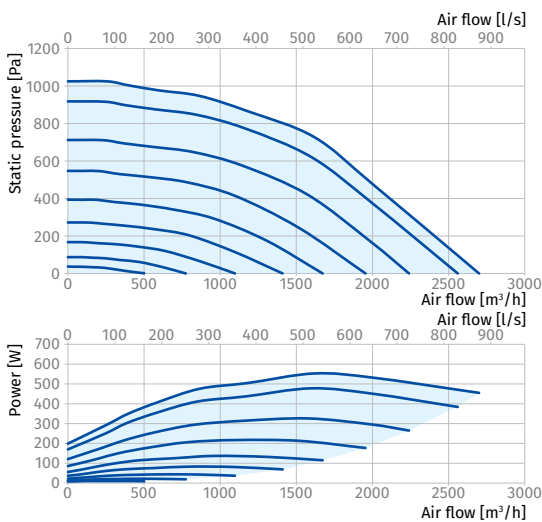

BOX EC 60x30-1

Sound power level, A-weighted	Total	Octave frequency bands [Hz]								LpA 3 m	LpA 1 m
		63	125	250	500	1000	2000	4000	8000		
LWA to inlet [dBA]	80	42	58	77	69	73	71	69	64	60	70
LWA to outlet [dBA]	83	40	56	76	77	75	79	73	66	63	73
LWA to environment [dBA]	68	42	51	66	62	56	55	50	42	48	58

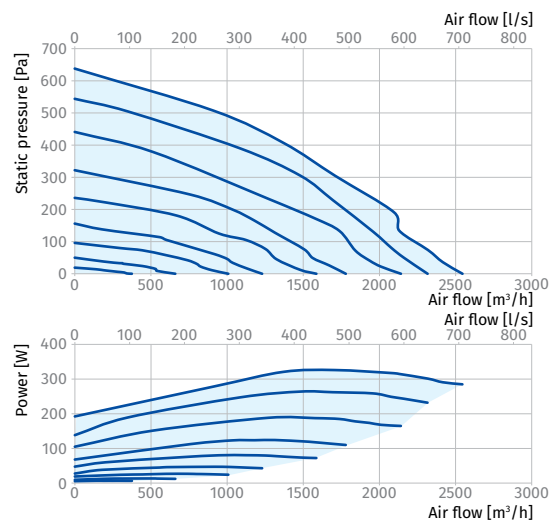

INLINE FANS FOR RECTANGULAR AIR DUCTS

NEW

Parameters	Box EC 60x30-1 max	Box EC 60x35-1	Box EC 60x35-3 max	Box EC 70x40-1
Voltage [V/50 (60) Hz]	1 ~ 230	1 ~ 230	3 ~ 400	1 ~ 230
Power [W]	425	361	1308	795
Current [A]	2.76	2.62	2.35	3.48
Maximum air flow [m³/h (l/s)]	3060 (850)	2815 (782)	4290 (1192)	5710 (1586)
RPM [min ⁻¹]	2160	2000	3160	1400
Sound pressure at 3 m [dBA]	50	49	55	53
Transported air temperature [°C]	-25...+50	-25...+50	-25...+50	-25...+50
SEC class	-	-	-	-
IP rating	IPX4	IPX4	IPX4	IPX4
Motor IP rating	IP54	IP54	IP54	IP54
ErP	2018	2018	2018	2018

BOX EC 60x30-1 MAX

Sound power level, A-weighted	Total	Octave frequency bands [Hz]								LpA 3 m	LpA 1 m
		63	125	250	500	1000	2000	4000	8000		
LWA to inlet [dBA]	82	56	78	80	64	54	49	54	45	62	72
LWA to outlet [dBA]	85	55	78	84	66	51	49	57	50	65	75
LWA to environment [dBA]	71	50	69	66	53	45	38	38	31	50	60

BOX EC 60x35-1

Sound power level, A-weighted	Total	Octave frequency bands [Hz]								LpA 3 m	LpA 1 m
		63	125	250	500	1000	2000	4000	8000		
LWA to inlet [dBA]	81	43	59	78	70	75	73	70	65	61	71
LWA to outlet [dBA]	85	41	57	77	78	76	80	75	67	64	74
LWA to environment [dBA]	69	43	52	67	63	57	56	50	43	49	59

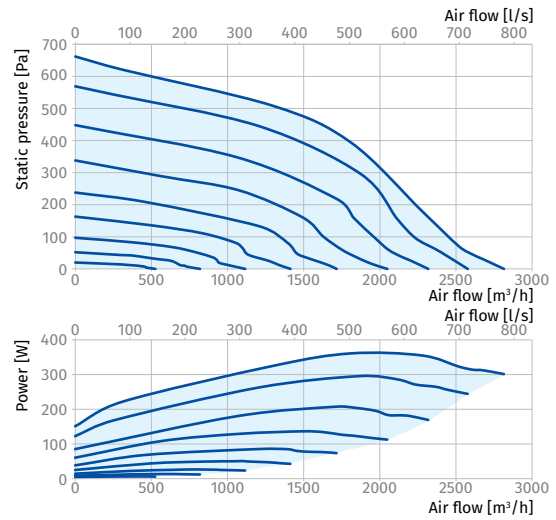
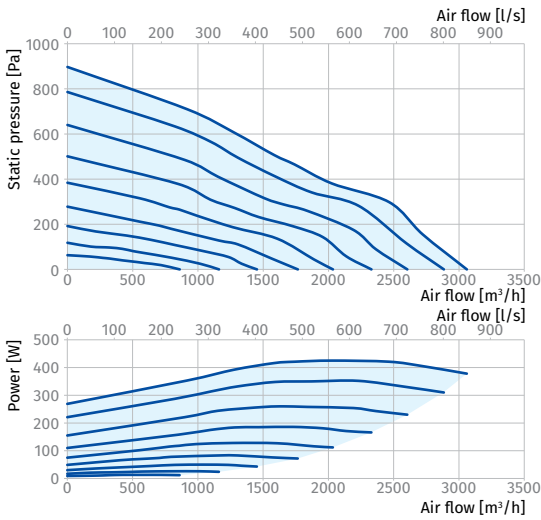

BOX EC 60x35-3 MAX

Sound power level, A-weighted	Total	Octave frequency bands [Hz]								LpA 3 m	LpA 1 m
		63	125	250	500	1000	2000	4000	8000		
LWA to inlet [dBA]	89	53	84	82	82	82	79	72	70	69	79
LWA to outlet [dBA]	88	50	83	80	82	83	76	69	65	68	78
LWA to environment [dBA]	76	52	74	68	63	63	57	49	43	55	65

BOX EC 70x40-1

Sound power level, A-weighted	Total	Octave frequency bands [Hz]								LpA 3 m	LpA 1 m
		63	125	250	500	1000	2000	4000	8000		
LWA to inlet [dBA]	85	45	62	82	74	78	76	74	68	64	74
LWA to outlet [dBA]	88	43	60	81	82	79	84	78	70	68	78
LWA to environment [dBA]	74	46	55	72	67	61	60	54	46	53	63

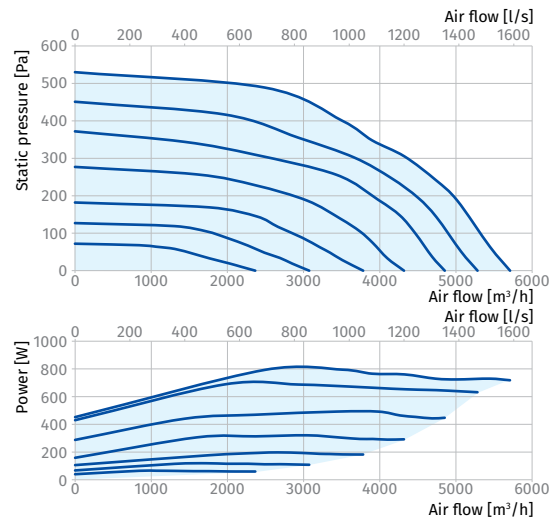
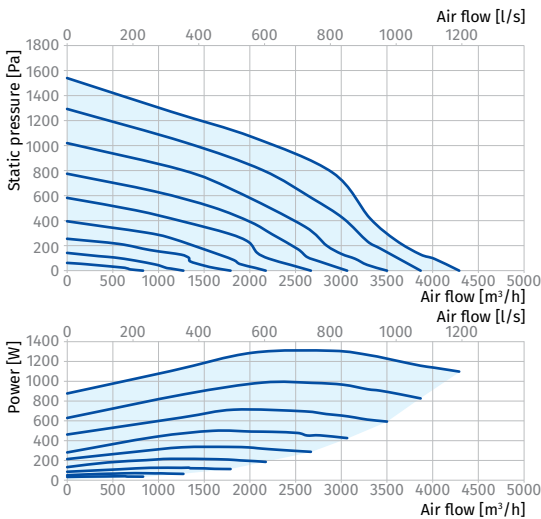

INLINE FANS FOR RECTANGULAR DUCTS

Parameters	Box EC 70x40-3 max	Box EC 80x50-3	Box EC 80x50-3 max	Box EC 90x50-3 max	Box EC 100x50-3 max
Voltage [V/50 (60) Hz]	3 ~ 400	3 ~ 400	3 ~ 400	3 ~ 400	3 ~ 400
Power [W]	2748	2025	2925	3429	3429
Current [A]	2.80	2.01	3.05	5.00	5.00
Maximum air flow [m³/h (l/s)]	6810 (1892)	8395 (2332)	8535 (2371)	11190 (3109)	11190 (3109)
RPM [min ⁻¹]	2530	1470	2400	1800	1800
Sound pressure at 3 m [dBA]	57	60	63	66	66
Transported air temperature [°C]	-25...+50	-25...+50	-25...+50	-25...+50	-25...+50
SEC class	-	-	-	-	-
IP rating	IPX4	IPX4	IPX4	IPX4	IPX4
Motor IP rating	IP54	IP54	IP54	IP54	IP54
ErP	2018	2018	2018	2018	2018

BOX EC 70x40-3 MAX

Sound power level, A-weighted	Total	Octave frequency bands [Hz]								LpA 3 m	LpA 1 m
		63	125	250	500	1000	2000	4000	8000		
LWA to inlet [dBA]	88	57	81	79	82	81	78	74	75	67	77
LWA to outlet [dBA]	92	56	82	85	85	86	81	75	75	71	81
LWA to environment [dBA]	77	55	75	71	67	65	60	55	52	57	67

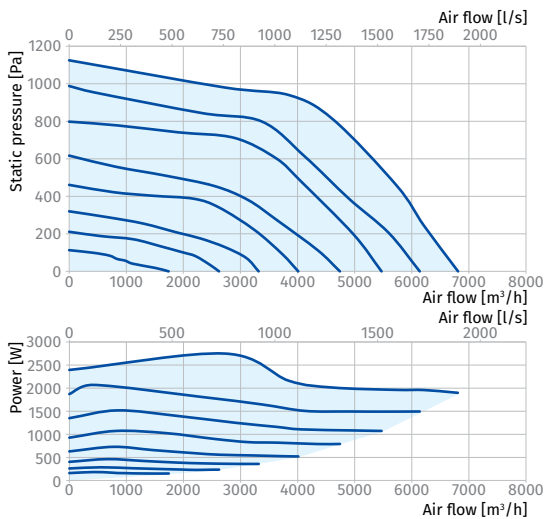

BOX EC 80x50-3

Sound power level, A-weighted	Total	Octave frequency bands [Hz]								LpA 3 m	LpA 1 m
		63	125	250	500	1000	2000	4000	8000		
LWA to inlet [dBA]	89	47	65	86	77	82	80	77	71	68	78
LWA to outlet [dBA]	92	44	62	84	85	83	88	82	73	71	81
LWA to environment [dBA]	81	50	61	79	74	67	66	59	50	60	70

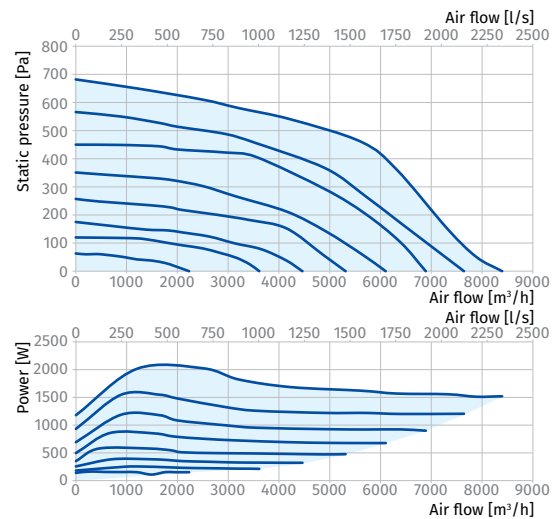

BOX EC 80x50-3 MAX

Sound power level, A-weighted	Total	Octave frequency bands [Hz]								LpA 3 m	LpA 1 m
		63	125	250	500	1000	2000	4000	8000		
LWA to inlet [dBA]	90	59	83	81	85	83	80	76	77	70	80
LWA to outlet [dBA]	93	57	84	87	87	88	83	76	76	73	83
LWA to environment [dBA]	83	59	81	77	72	70	65	59	56	63	73

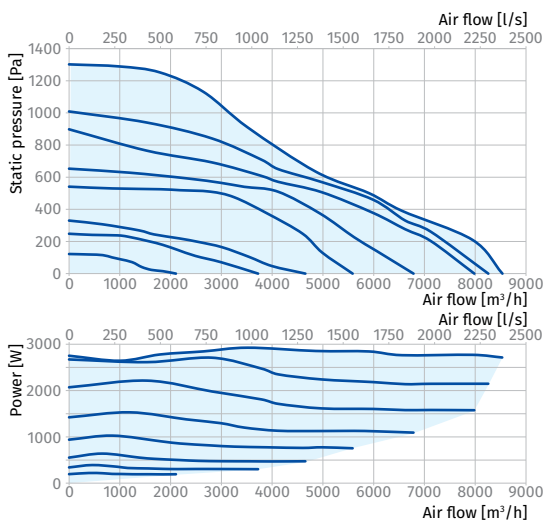

BOX EC 90x50-3 MAX, BOX EC 100x50-3 MAX

Sound power level, A-weighted	Total	Octave frequency bands [Hz]								LpA 3 m	LpA 1 m
		63	125	250	500	1000	2000	4000	8000		
LWA to inlet [dBA]	92	60	85	83	87	85	82	78	79	71	81
LWA to outlet [dBA]	94	58	85	88	88	89	84	77	77	74	84
LWA to environment [dBA]	86	62	84	80	75	73	67	62	58	66	76

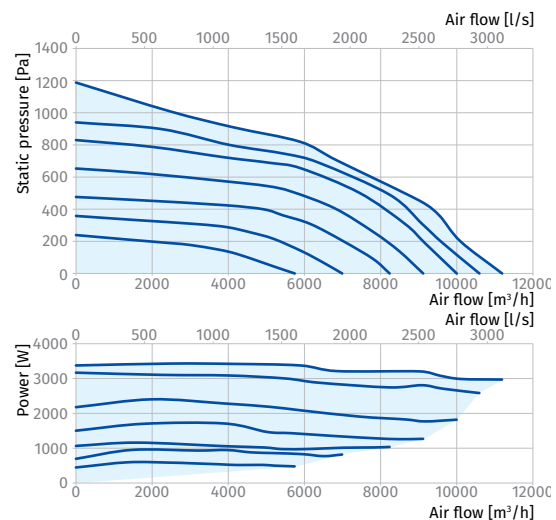

INLINE FANS FOR RECTANGULAR AIR DUCTS