

BLAUBOX MW PRO

Supply ventilation units

Features

- Ventilation units for efficient supply ventilation in various premises.
- Controllable air supply, heating and filtration.
- Compatible with 400x200 up to 800x500 mm rectangular air ducts.



Air flow:
up to 6500 m³/h
1806 l/s



Design

- The casing is made of double-skinned aluzinc panels, internally filled with 25 mm mineral wool layer for heat and sound insulation.
- The casing has fixing brackets with vibration absorbing connectors for easy installation.
- The hinged casing side panel ensures easy access to the internals for cleaning, filter replacement and other maintenance operations.

Fans

- Asynchronous external rotor motor and centrifugal double-intake impeller with forward curved blades is used for air supply.
- Single- or three-phase motor modification depending on the fan model type.
- Integrated motor overheating protection with automatic restart.
- Dynamically balanced impeller.
- Equipped with ball bearings for longer service life.
- Reliable and quiet operation.

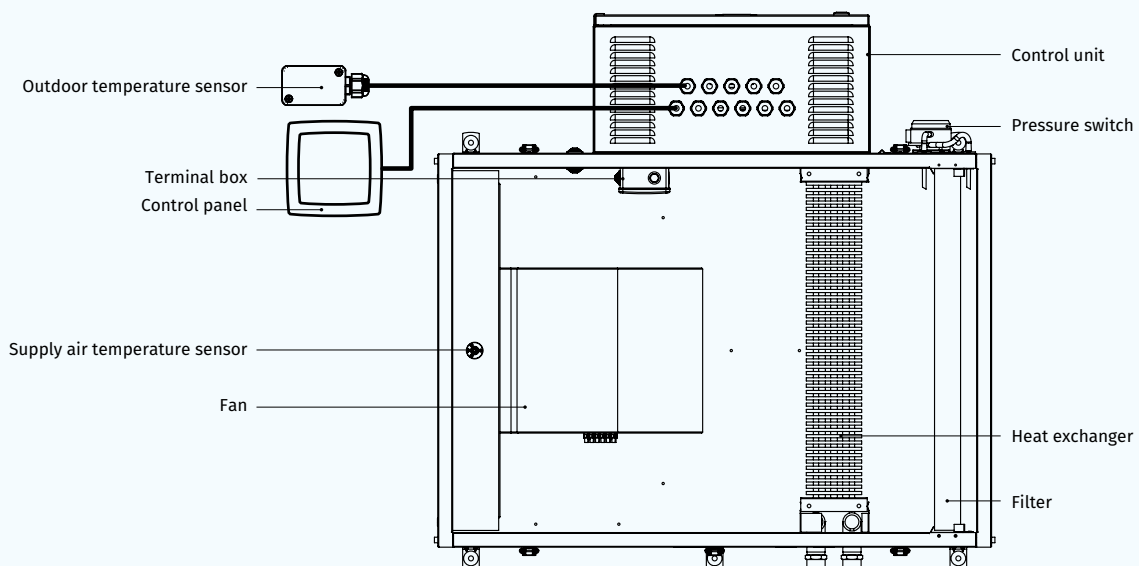

Air heater

- The units are equipped with a water (glycol) heater for operation during cold seasons at low outside temperature.
- The air temperature sensor downstream of the water heater and the return heat medium sensor ensure freezing protection of the water heater. If any of these sensors detects a temperature point below the set minimum value, the signal is sent automatically to the control unit to troubleshoot cooling.

Air filtration

- The built-in G4 supply filter provides air filtration.

Control and automation

- The units incorporate an integrated control system with a wall-mounted control panel and LCD display.
- The standard delivery set includes a 10 m cable for connection of the unit and the control panel.
- **Control panel functions:**
 - Activating/deactivating the unit.
 - Setting low, medium and high speeds for the supply fan. Air flow control.
 - The models with a water mixing unit have the function of setting and maintaining the supply air temperature by means of controlling the heat medium control valve.

Automation functions:

- Supply air temperature control by means of controlling the heat medium control valve.
- Control of the supply air damper actuator (separate order).
- Control of the external circulation pump on the heat medium feed line.
- Regulation of heat medium flow in the water heater in case of the differential pressure of the return heat medium below 40 kPa.
- Water heater freezing protection with the mixing unit and the circulation pump.
- Control of the cooler with respect to the set indoor air temperature (separate order).
- Supply fan control.
- Supply filter clogging control.
- Shutdown of the unit on signal from the fire alarm panel.

Mounting

- The unit is suitable for mounting on the floor, ceiling mounting or wall mounting with fixing brackets in any mounting position except for the vertical one with air flow downwards.
- The correct mounted unit must provide free access to the hinged panel for servicing and filter replacement.

Designation key

Series	Casing modification	Heater type	Rated air flow [m³/h]	Number of water coil rows	Control
BLAUBOX	M: single-block unit	W: water heater	750; 1200; 1800; 2100; 3000; 3200; 6500	– 4	Pro: with control panel

Overall dimensions [mm]

Model	B3	B	B2	H1	H	L
BLAUBOX MW 750-4 Pro	400	500	674	200	352	650
BLAUBOX MW 1200-4 Pro	400	500	674	200	352	650
BLAUBOX MW 1800-4 Pro	500	600	775	250	480	800
BLAUBOX MW 2100-4 Pro	500	600	775	300	480	800
BLAUBOX MW 3000-4 Pro	600	710	1000	300	530	1000
BLAUBOX MW 3200-4 Pro	600	710	1000	350	530	1000
BLAUBOX MW 6500-4 Pro	800	925	1212	500	670	1299

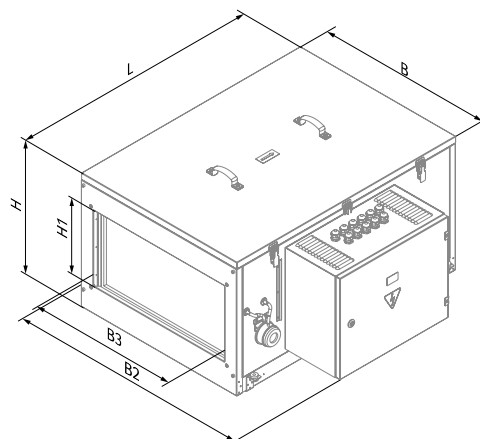

Technical data

Parameters	BLAUBOX MW 750-4 Pro	BLAUBOX MW 1200-4 Pro	BLAUBOX MW 1800-4 Pro	BLAUBOX MW 2100-4 Pro
Voltage [V / 50 Hz]	1 ~ 230	1 ~ 230	1 ~ 230	1 ~ 230
Number of water (glycol) coil rows	4	4	4	4
Power [kW]	0.245	0.410	0.490	0.650
Current [A]	1.08	1.8	2.15	2.84
Maximum air flow [m ³ /h (l/s)]	750 (208)	1200 (333)	1870 (519)	2150 (597)
RPM [min ⁻¹]	1650	1850	1100	1000
Sound pressure level at 3 m [dBA]	35	38	40	45
Transported air temperature [°C]	-25...+40	-25...+40	-25...+40	-25...+40
Casing material	aluzinc	aluzinc	aluzinc	aluzinc
Insulation	25 mm mineral wool	25 mm mineral wool	25 mm mineral wool	25 mm mineral wool
Supply filter	G4	G4	G4	G4
Connected air duct diameter [mm]	400x200	400x200	500x250	500x300
Weight [kg]	41.3	42.8	62.5	63
SEC class	D	-	-	-
ErP	2016, 2018	2016, 2018	2016, 2018	2016, 2018

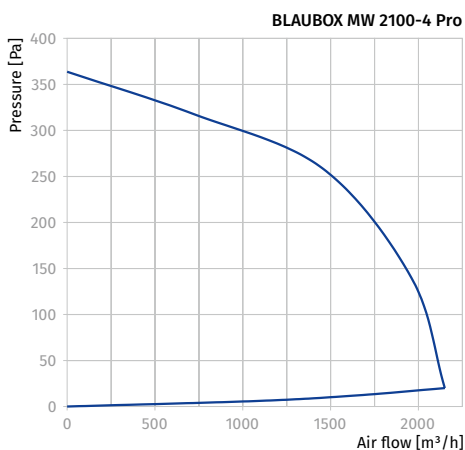
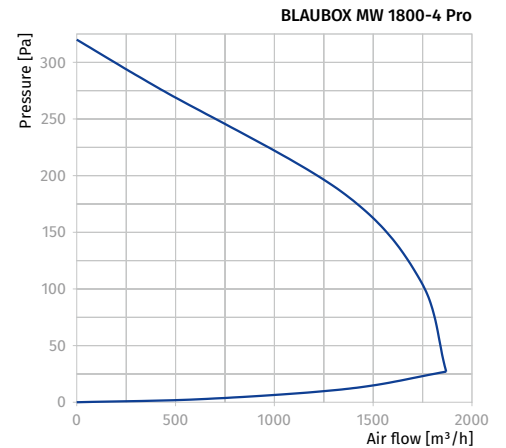
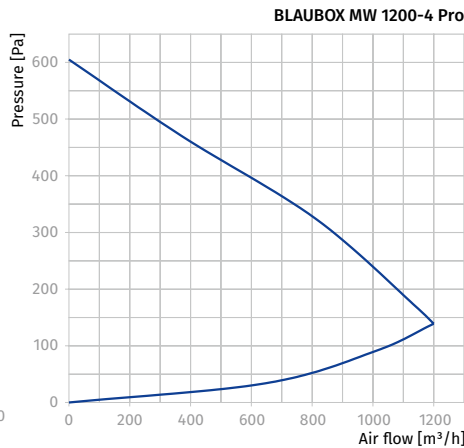
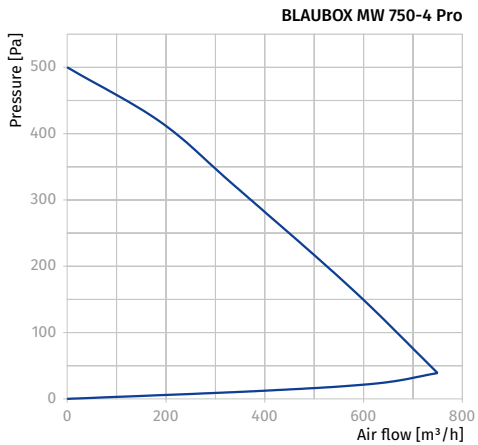

Parameters	BLAUBOX MW 3000-4 Pro	BLAUBOX MW 3200-4 Pro	BLAUBOX MW 6500-4 Pro
Voltage [V / 50 Hz]	3 ~ 400Y	3 ~ 400Y	3 ~ 400
Number of water (glycol) coil rows	4	4	4
Power [kW]	1.27	1.27	1.80
Current [A]	2.3	2.3	4.5
Maximum air flow [m³/h (l/s)]	3000 (833)	3250 (903)	6500 (1806)
RPM [min ⁻¹]	1200	1200	1400
Sound pressure level at 3 m [dBA]	53	53	55
Transported air temperature [°C]	-40...+45	-40...+45	-25...+40
Casing material	aluzinc	aluzinc	aluzinc
Insulation	25 mm mineral wool	25 mm mineral wool	25 mm mineral wool
Supply filter	G4	G4	G4
Connected air duct diameter [mm]	600x300	600x350	800x500
Weight [kg]	73.2	73.1	136
SEC class	-	-	-
ErP	2016, 2018	2016, 2018	2016, 2018

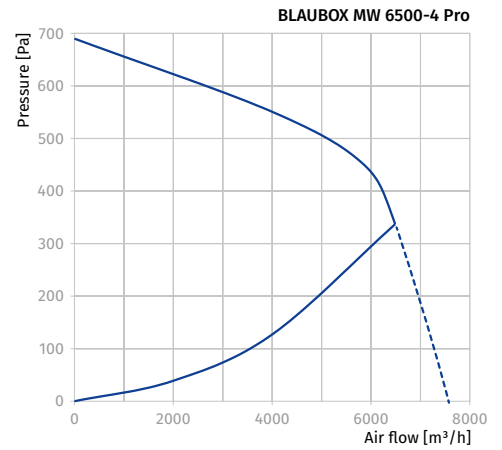
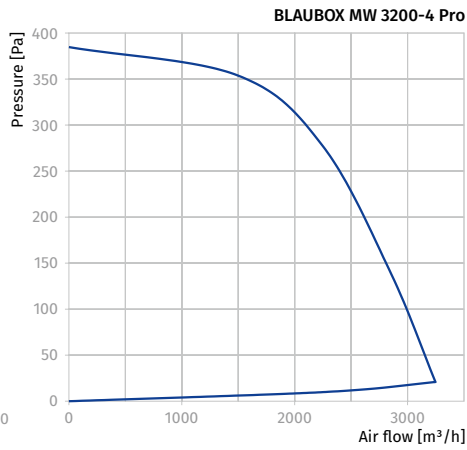
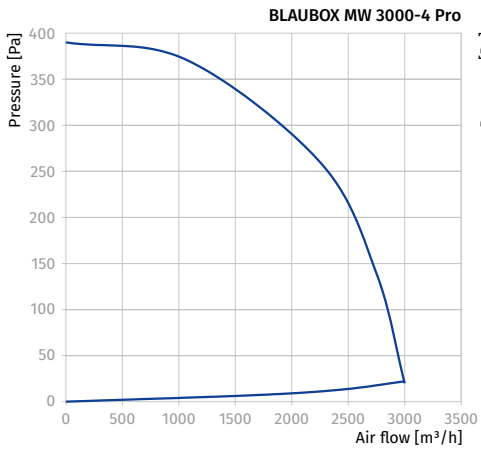

SUPPLY VENTILATION UNITS

Hot water coil calculation diagram

BLAUBOX MW 750-4 PRO / BLAUBOX MW 1200-4 PRO

Air temperature downstream of the water heating coils [°C]

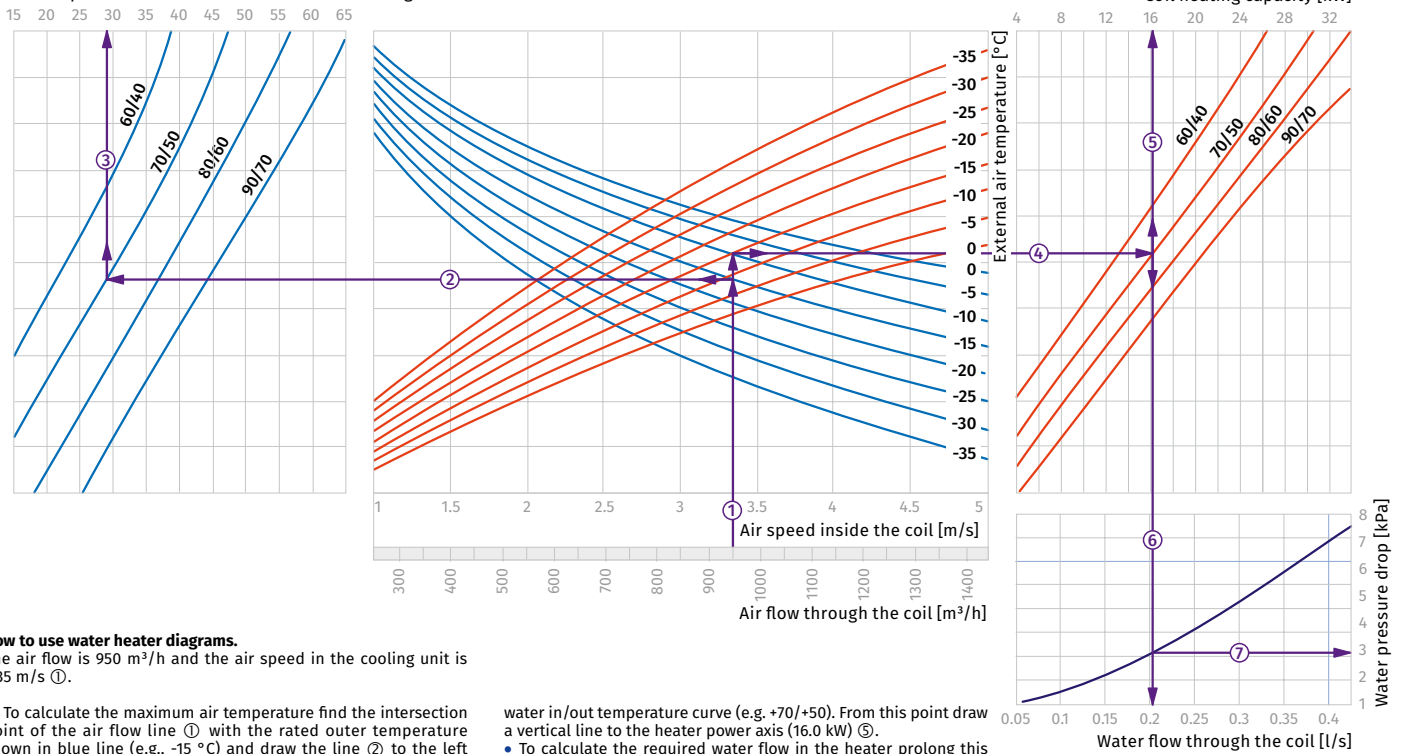

How to use water heater diagrams.

The air flow is 950 m³/h and the air speed in the cooling unit is 3.35 m/s ①.

- To calculate the maximum air temperature find the intersection point of the air flow line ① with the rated outer temperature shown in blue line (e.g., -15 °C) and draw the line ② to the left until it crosses the water in/out temperature curve (e.g. +70/+50). From this point draw a vertical line to the supply air temperature downstream of the heater (+29 °C) ③.
- To calculate the heater power find the intersection point of the air flow ① with the rated winter temperature shown in red line (e.g., -15 °C) and draw the line ④ to the right until it crosses the

water in/out temperature curve (e.g. +70/+50). From this point draw a vertical line to the heater power axis (16.0 kW) ⑤.

- To calculate the required water flow in the heater prolong this line ⑥ downwards to the water flow axis (0.2 l/s).
- To calculate the water pressure drop in the heater find the intersection point of the line ⑥ with the pressure loss curve and prolong the line ⑦ to the right on the water pressure drop axis (2.1 kPa).

BLAUBOX MW 1800-4 PRO / BLAUBOX MW 2100-4 PRO

Air temperature downstream of the water heating coils [°C]

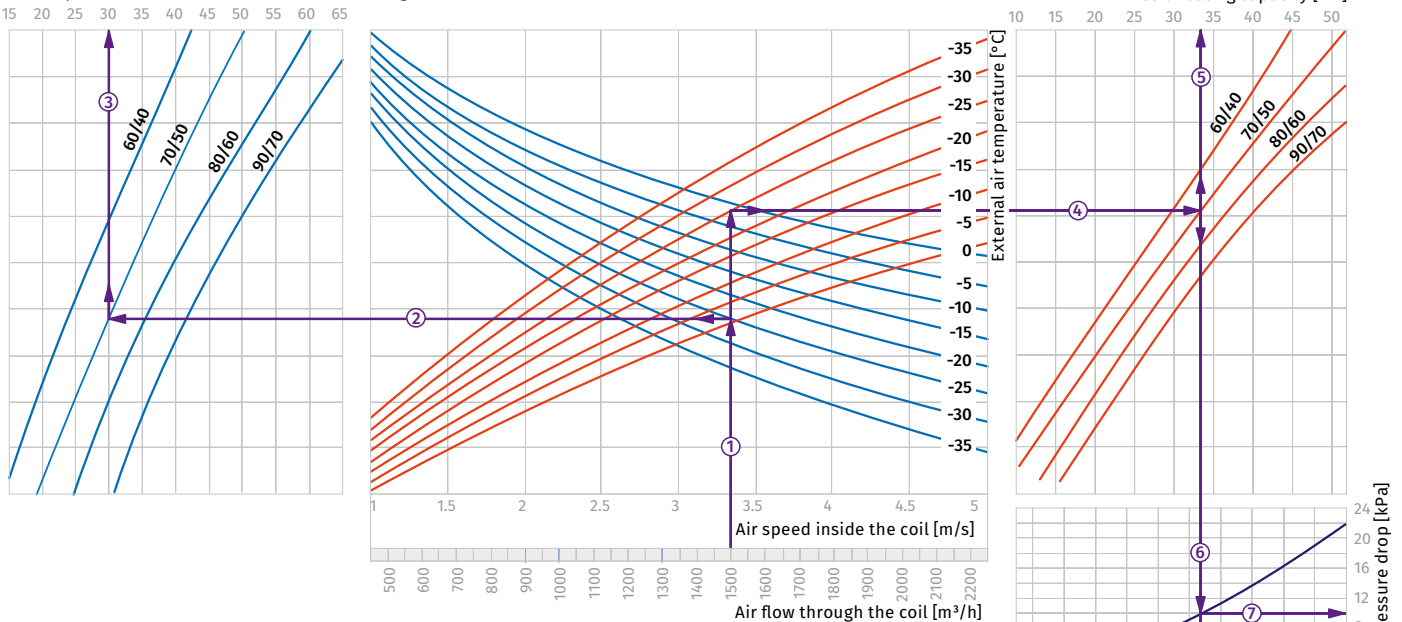

How to use water heater diagrams.

The air flow is 1500 m³/h and the air speed in the cooling unit is 3.5 m/s ①.

- To calculate the maximum air temperature find the intersection point of the air flow line ① with the rated outer temperature shown in blue line (e.g., -25 °C) and draw the line ② to the left until it crosses the water in/out temperature curve (e.g. +70/+50). From this point draw a vertical line to the supply air temperature downstream of the heater (+30 °C) ③.
- To calculate the heater power find the intersection point of the air flow ① with the rated winter temperature shown in red line (e.g., -25 °C) and draw the line ④ to the right until it crosses the

water in/out temperature curve (e.g. +70/+50). From this point draw a vertical line to the heater power axis (33.0 kW) ⑤.

- To calculate the required water flow in the heater prolong this line ⑥ downwards to the water flow axis (0.42 l/s).
- To calculate the water pressure drop in the heater find the intersection point of the line ⑥ with the pressure loss curve and prolong the line ⑦ to the right on the water pressure drop axis (10.0 kPa).

BLAUBOX MW 3000-4 PRO / BLAUBOX MW 3200-4 PRO

Air temperature downstream of the water heating coils [°C]

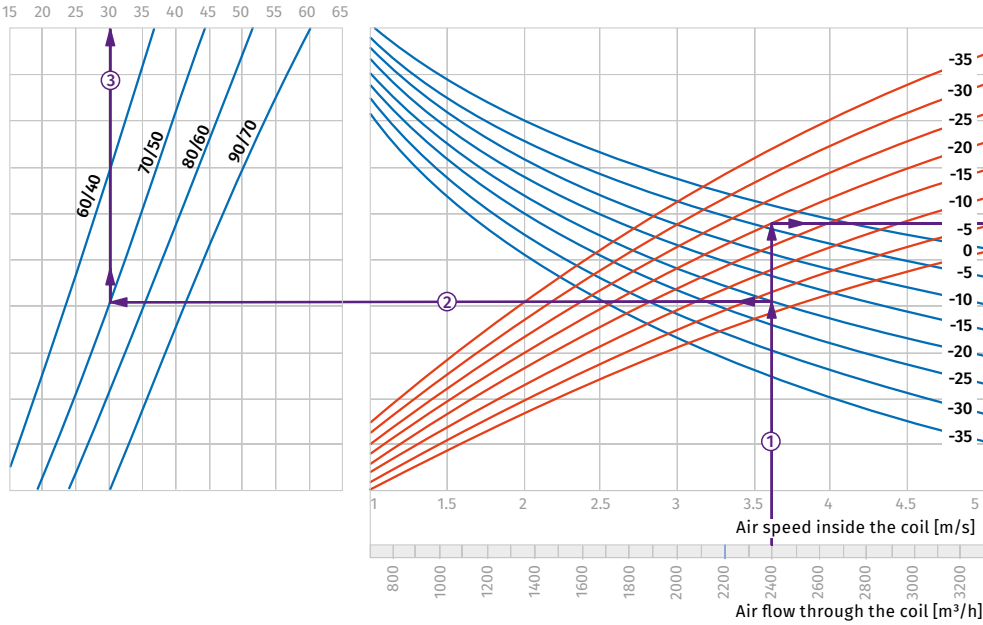

How to use water heater diagrams.

The air flow is 2400 m³/h and the air speed in the cooling unit is 3.61 m/s ①.

- To calculate the maximum air temperature find the intersection point of the air flow line ① with the rated outer temperature shown in blue line (e.g., -20 °C) and draw the line ② to the left until it crosses the water in/out temperature curve (e.g. +70/+50). From this point draw a vertical line to the supply air temperature downstream of the heater (+30 °C) ③.
- To calculate the heater power find the intersection point of the air flow ① with the rated winter temperature shown in red line (e.g., -20 °C) and draw the line ④ to the right until it crosses the

water in/out temperature curve (e.g. +70/+50). From this point draw a vertical line to the heater power axis (50.0 kW) ⑤.

- To calculate the required water flow in the heater prolong this line ⑥ downwards to the water flow axis (0.62 l/s).
- To calculate the water pressure drop in the heater find the intersection point of the line ⑥ with the pressure loss curve and prolong the line ⑦ to the right on the water pressure drop axis (15.0 kPa).

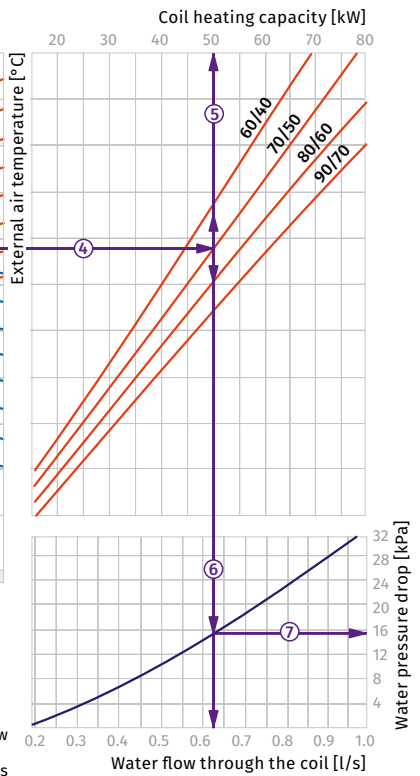

BLAUBOX MW 6500-4 PRO

Air temperature downstream of the water heating coils [°C]

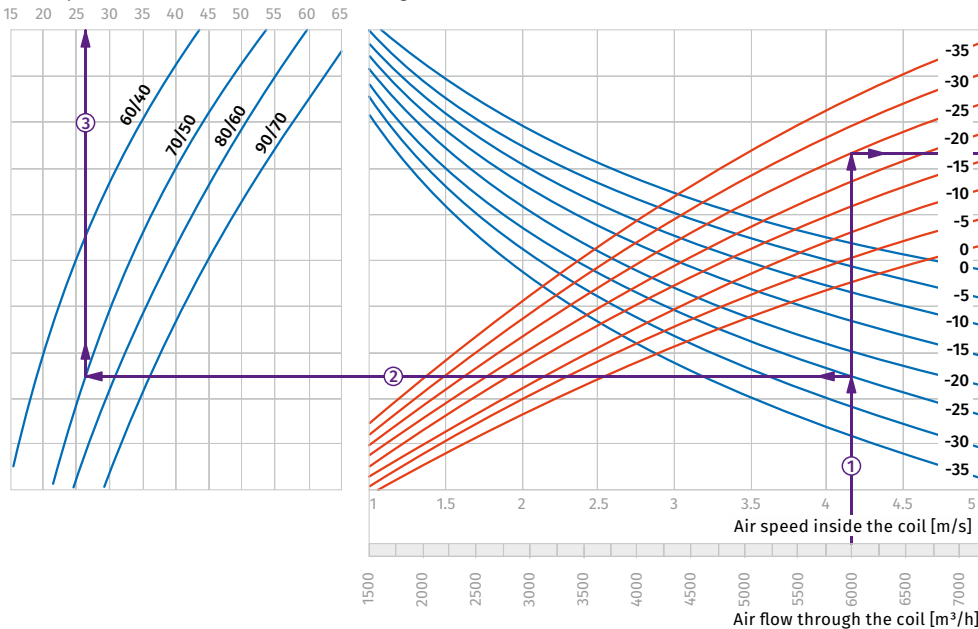

How to use water heater diagrams.

The air flow is 6000 m³/h and the air speed in the cooling unit is 4.15 m/s ①.







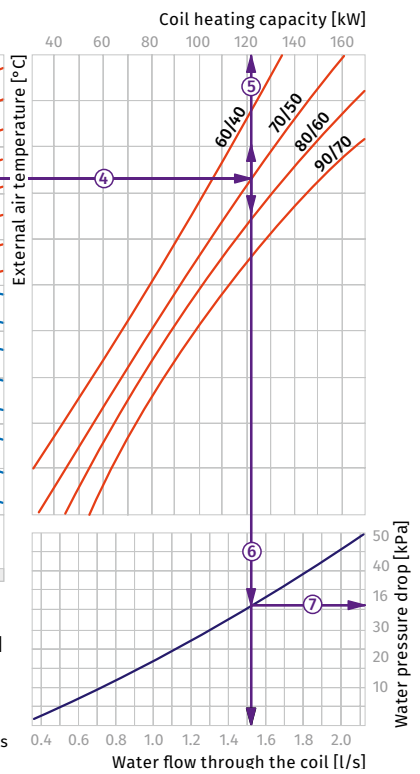

- To calculate the maximum air temperature find the intersection point of the air flow line ① with the rated outer temperature shown in blue line (e.g., -25 °C) and draw the line ② to the left until it crosses the water in/out temperature curve (e.g. +70/+50). From this point draw a vertical line to the supply air temperature downstream of the heater (+27 °C) ③.
- To calculate the heater power find the intersection point of the air flow ① with the rated winter temperature shown in red line (e.g., -25 °C) and draw the line ④ to the right until it crosses the water in/out temperature curve (e.g. +70/+50). From this point draw a vertical line to the heater power axis (121.0 kW) ⑤.









• To calculate the required water flow in the heater prolong this line ⑥ downwards to the water flow axis (1.52 l/s).

- To calculate the water pressure drop in the heater find the intersection point of the line ⑥ with the pressure loss curve and prolong the line ⑦ to the right on the water pressure drop axis (31.0 kPa).



Accessories

		BLAUBOX MW 750-4 Pro	BLAUBOX MW 1200-4 Pro	BLAUBOX MW 1800-4 Pro	BLAUBOX MW 2100-4 Pro
G4 panel filter		FP 442x275x47 G4	FP 442x275x47 G4	FP 545x390x47 G4	FP 545x390x47 G4
G4 pocket filter		-	-	-	-
Silencer		SD 40x20	SD 40x20	SD 50x25	SD 50x30
Duct cooling unit		KFK 40x20-3	KFK 40x20-3	KFK 50x25-3	KFK 50x30-3
Duct cooling unit		KWK 40x20-3	KWK 40x20-3	KWK 50x25-3	KWK 50x30-3
Water mixing unit		WMG	WMG	WMG	WMG
Air flow dampers		SL 40x20	SL 40x20	SL 50x25	SL 50x30
Flexible anti-vibration connector		EVA 40x20	EVA 40x20	EVA 50x25	EVA 50x30
Air damper electric actuator		TF230	TF230	TF230	TF230

		BLAUBOX MW 3000-4 Pro	BLAUBOX MW 3200-4 Pro	BLAUBOX MW 6500-4 Pro
G4 panel filter		FP 653x440x47 G4	FP 653x440x47 G4	-
G4 pocket filter		-	-	FPT 868x573x27 G4
Silencer		SD 60x30	SD 60x35	SD 80x50
Duct cooling unit		KFK 60x30-3	KFK 60x35-3	KFK 80x50-3
Duct cooling unit		KWK 60x30-3	KWK 60x35-3	KWK 80x50-3
Water mixing unit		WMG	WMG	WMG
Air flow dampers		SL 60x30	SL 60x35	SL 80x50
Flexible anti-vibration connector		EVA 60x30	EVA 60x35	EVA 80x50
Air damper electric actuator		TF230	TF230	TF230