

COMPACT UNITS

BLAUAIR BLS



THE NEW GENERATION
OF PROFESSIONAL VENTILATION

2

COMPACT UNITS

BLAUAIR BLS

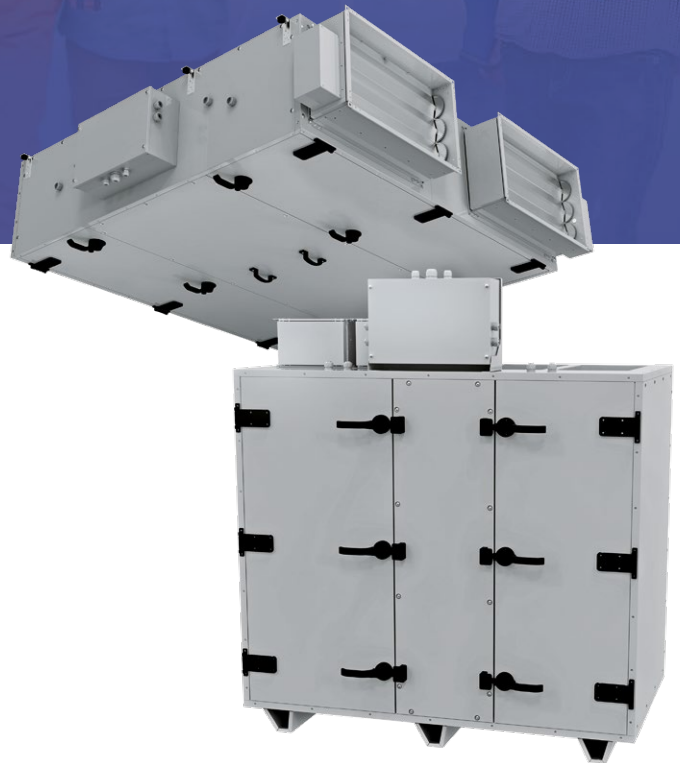

THE NEW GENERATION OF COMPACT COMMERCIAL AIR HANDLING UNITS



1000 – 9000 m³/h

FEATURES

Air flow capacity: 1000 – 9000 m³/h.

Control box mounted on the casing, outside the unit.

Modular frameless casing design.

Integrated water and electric heaters in vertical units.

Hygroscopic rotary heat exchanger as an option.

Compact height for ceiling-mounted units (from 400 mm) and optimized width (from 800 mm) for the vertical ones.

Optimized split-up system for units with the bigger capacity.

Improved design with better performance

T2 / TB2 / L1 / D1

The construction of the case with a PVC profile ensures the absence of thermal bridges, minimizes heat loss and reduces the noise level.

TB2

Thermal bridging

L1

Leakage

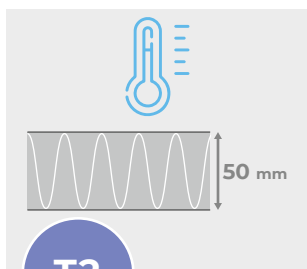
T2

Thermal transmittance

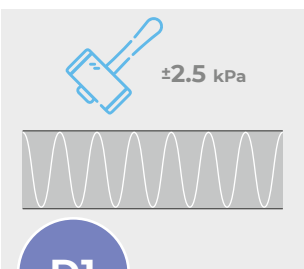
D1

Mechanical strength

Heat exchangers

Heat exchanger efficiency up to 90 % – efficient in energy saving and reducing ventilation system costs.

Air handling units with a sorption rotor have high efficiency and keep comfortable humidity with low risk of frosting.

High-efficiency counter-flow heat exchangers with lower pressure losses. By default, the regenerators are equipped with a bypass damper.



Sizes and capacities of BLS Compact units

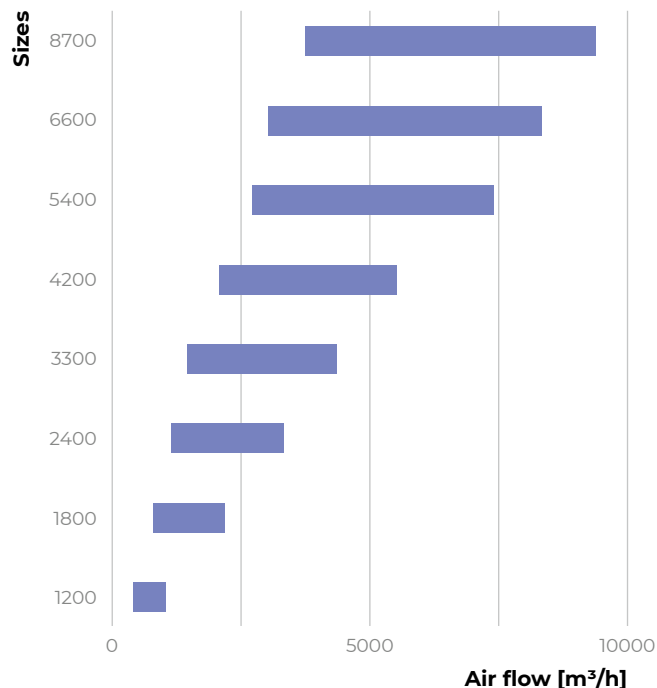

Fans with ultra premium class motors and FanGrids

Electronically commutated direct current motors (EC motors) with an external rotor, which are equipped with a backward curved impeller, are used. Such motors with an IE5 class are the most progressive solution for energy saving.

In FanGrids, multiple small fans operate in parallel, rather than having one large fan. This provides redundancy, ensuring fail-safe operation.



Design

1. Condensing counter-flow heat exchanger.
2. Integrated bypass with Belimo drive.
3. EC type fans with plastic or metal impellers.
4. Casing with 50 mm mineral wool insulation and AlZn skins, optional galvanized coated.
Casing properties: D1(M), L1(M), F9(M), T2, TB2.
5. Panel filters with ePM2.5 70% / ePM10 55% filtration classes.
6. External control cabinet with easy access.
7. Damper with Belimo drive.
8. Rotary heat exchanger: condensation or sorption with rotation control.

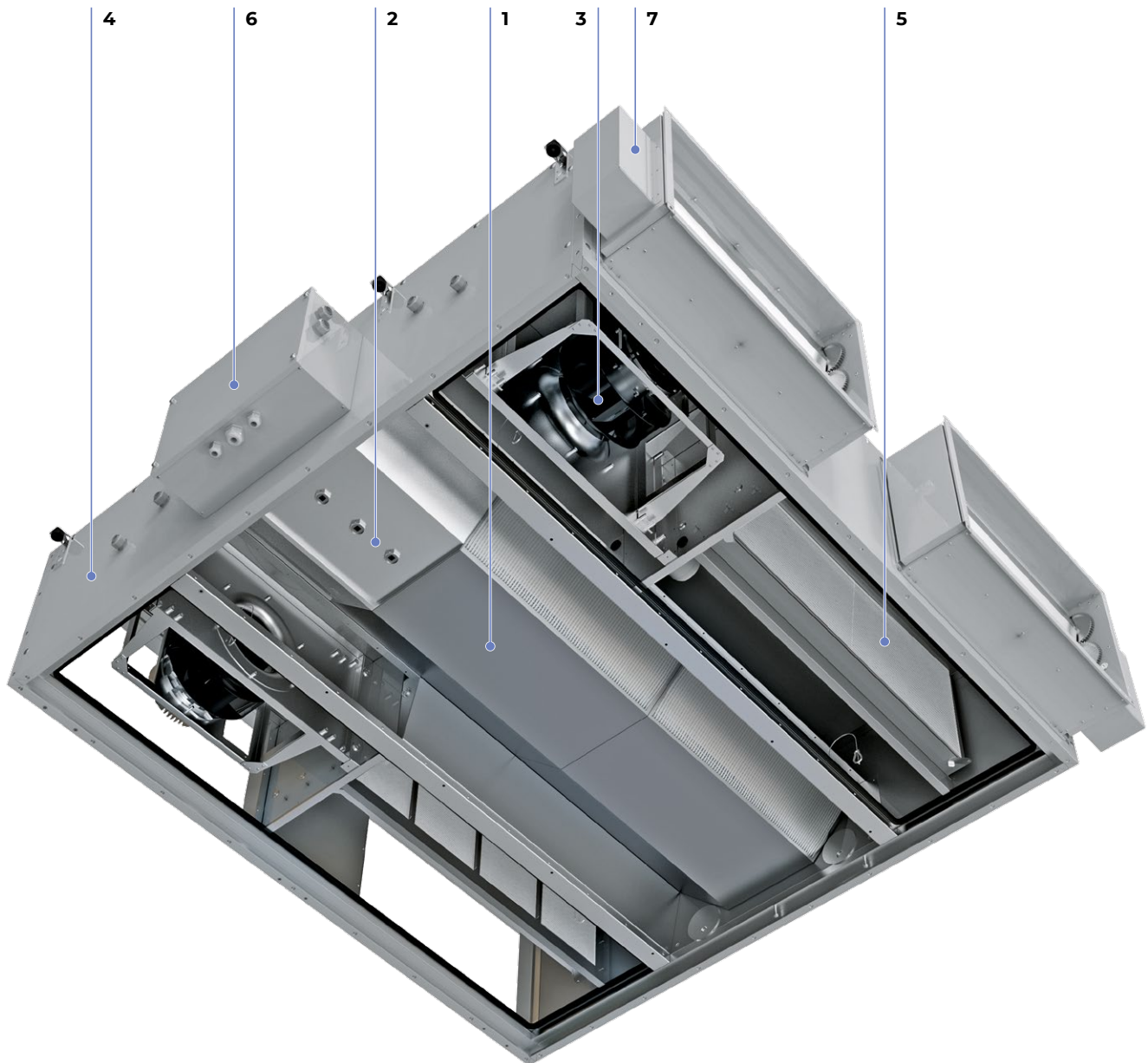

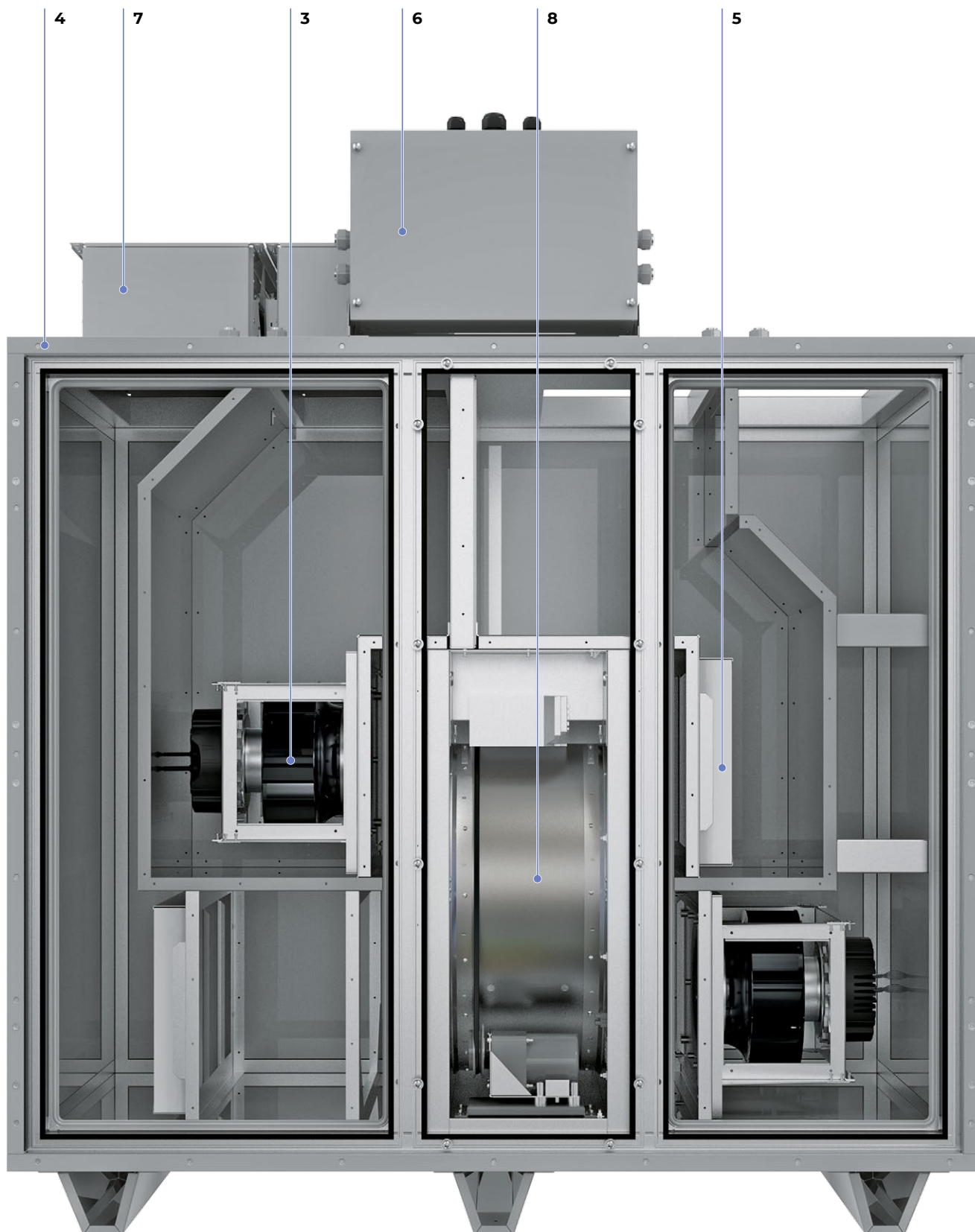

Integrated control system

Plug-and-play unit: full electric wiring.

Additional option – full factory electric wiring includes:

Installation of air damper actuators. Routing the contacts from actuators to the terminal box.

Installation of differential pressure switches in filter sections. Installation of a relay actuation threshold to the necessary level (final pressure drop according to the selection).

Installation of frost protection thermostats in water heating coils sections.

Installation of the VFD in the rotary heat exchanger section.

Installation of bypass damper actuators in the plate heat exchanger section.

Routing all electric contacts in the electric heater sections.

Routing all electric contacts in the fan sections.

Installation and adjustment of all temperature and humidity sensors inside the unit.

All the electric contacts are routed to the junction box, which is mounted in one of the sections.

Plug-and-play option implies the possibility of shipment in separate blocks. In this case, joints and connection boxes are installed between the sections.

Building Management Systems

BlauAir BLS units control system can be easily integrated into building management systems (SCADA, BMS, "smart house").

All the information processed by a programmable logic controller, is easily accessible via standard communication protocols:

- MODBUS TCP;
- LON WORKS.

Any other protocol can be used according to customer's choice and project requirements.

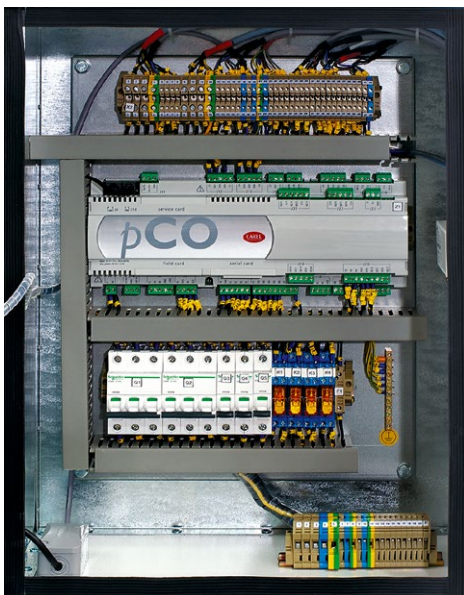



Blauberg Ventilatoren GmbH
Stäblistraße 6
81477 Munich, Germany
HRB 203341

info@blaubergventilatoren.de

Technical changes reserved.
Illustrations and texts are non-binding.

2|2024

