

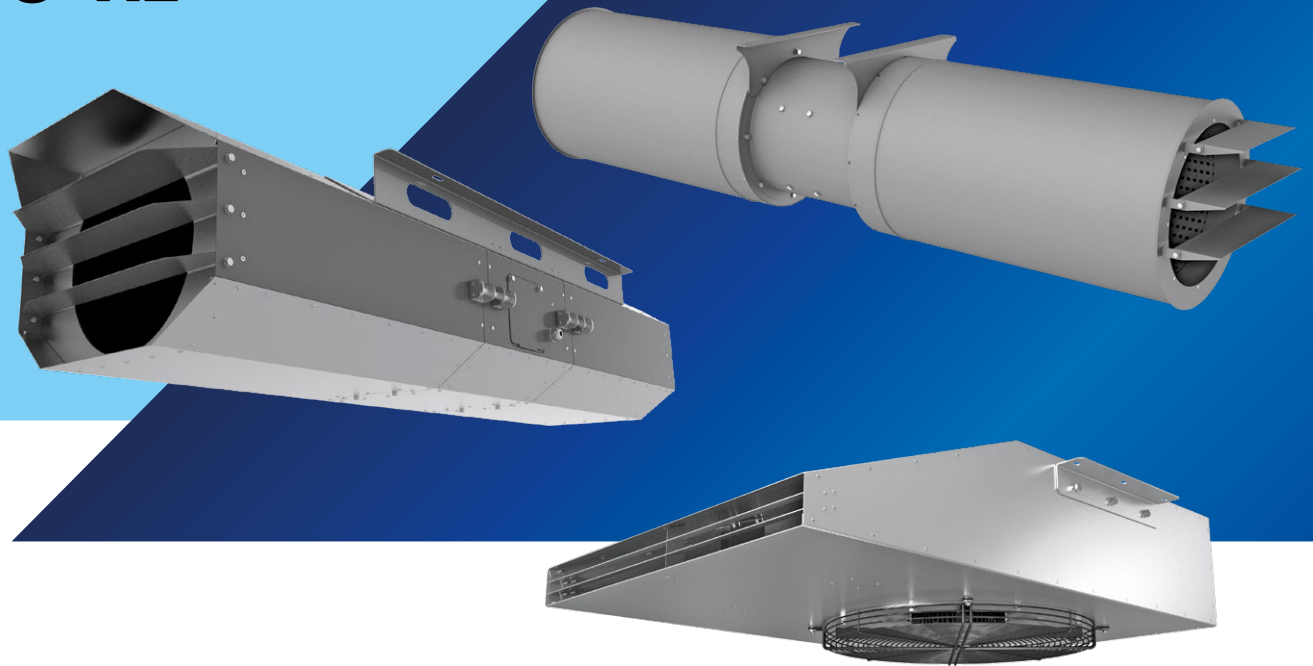

60 Hz



SMOKE EXTRACTION VENTILATION FOR PARKING PREMISES

SMOKE EXTRACTION PRODUCT CATALOGS



**MEDIUM PRESSURE AXIAL
FANS AND AXIAL SMOKE
EXTRACTION FANS**



**CENTRIFUGAL SMOKE
EXTRACTION FANS**



**SMOKE EXTRACTION VENTILATION
FOR PARKING PREMISES**



FIRE SAFETY DAMPERS



60 Hz



**MEDIUM PRESSURE AXIAL
FANS AND AXIAL SMOKE
EXTRACTION FANS**



60 Hz



**SMOKE EXTRACTION VENTILATION
FOR PARKING PREMISES**



CONTENTS

| | |
|---|----|
| Smoke extraction systems | 2 |
| AXIS-JET. Jet axial fans | 4 |
| CENTRO-JET. Induction centrifugal fans | 10 |
| Ventilation system for underroof parking | 12 |
| Smoke extraction system for underroof parking | 14 |
| Operation of fans with frequency converters | 16 |
| Frequency converters | 17 |

SMOKE EXTRACTION SYSTEMS



SMOKE EXTRACTION SYSTEMS

- Smoke control is a complex process involving smoke extraction and fresh air supply by the supply and extract ventilation system of buildings in order to ensure safe evacuation of people in case of a fire in any of the spaces.
- Ventilation systems for underroof parking are designed to ensure the most important functions. Such systems are designed to protect people escaping fire through the evacuation routes against hazardous fire factors by extracting harmful combustion products and preventing their spreading in the air.
- According to conclusive evidence the majority of mortalities in a fire are caused by poisoning from carbon monoxide and other combustion products. Carbon monoxide is one of the most toxic smoke components. It is carbon monoxide poisoning that accounts for 80 % of the fire accident causes. Fires in closed spaces where oxygen supply is limited are especially prone to intensive carbon monoxide generation.

- Smoke is able to cause loss of consciousness and cardiac standstill before a person may leave a house on fire. Jet ventilation system is the most suitable and safe ventilation solution for modern underground parkings. Arrangement of such ventilation requires no ductwork layout, thus the involved mounting expenses are reduced by 45 %. The energy losses caused by aerodynamic resistance in the air ducts are also reduced. The jet ventilation system design requires no complicated annual cleaning of the ductworks, thus reducing the maintenance costs by 35-40 %.
- Axial fans are used for general ventilation purposes of underground and semiopened parkings, covered shelters, ventilation of tunnels, air recirculation in atriums and air supply to panoramic glass constructions. Such ventilation system does not require installation of ductworks and the air stream flows directly from air supply vent to air exhaust vent.

Impurity content in the air [mg/m³] and health effect

| Influence | CO | SO ₂ | NOx |
|--|-------------|-----------------|-----|
| No marked effect in case of exposure for several hours | 115 | 6 | 15 |
| Symptoms of light poisoning or mucous membrane irritation in 2-3 hours | 115...575 | 130 | 20 |
| Poisoning in 30 minutes | 2300...3500 | 210...400 | 100 |
| Life hazard even if short-term exposure | 5700 | 1600 | 150 |

Composition of automotive exhaust gases

| Content, volume in % | Petrol type | Diesel type |
|--|--------------------------|-----------------------|
| N ₂ | 74-77 | 76-78 |
| O ₂ | 0.3-0.8 | 2.0-18.0 |
| H ₂ O (vapours) | 3.0-5.5 | 0.5-4.0 |
| CO ₂ | 0.0-16.0 | 1.0-10.0 |
| CO* | 0.1-5.0 | 0.01-0.5 |
| Nitrogen oxide* | 0.0-0.8 | 0.0002-0.5000 |
| Hydrocarbons* | 0.2-3.0 | 0.09-0.500 |
| Aldehydes* | 0.0-0.2 | 0.001-0.009 |
| Soot** [g/m ³] | 0.0-0.04 | 0.01-1.10 |
| Benzpyrene _{3,4} ** [g/m ³] | 10-20 x 10 ⁻⁶ | 10 x 10 ⁻⁶ |

* Toxic components
** Carcinogens

Axis-Jet-CI axial jet fan design

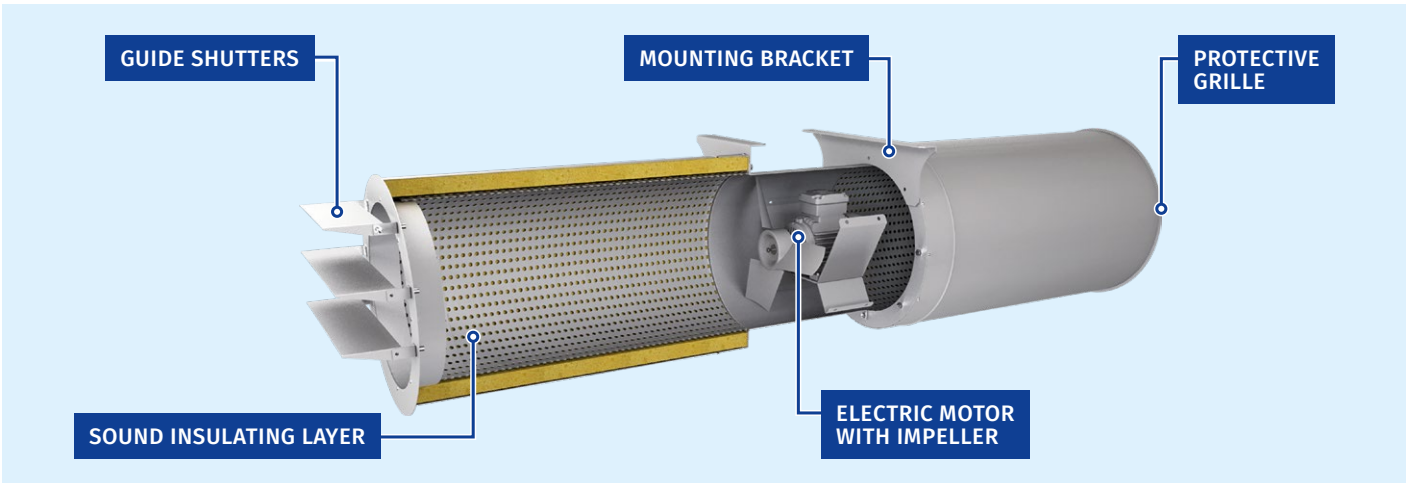

Axis-Jet-VI axial jet fan design

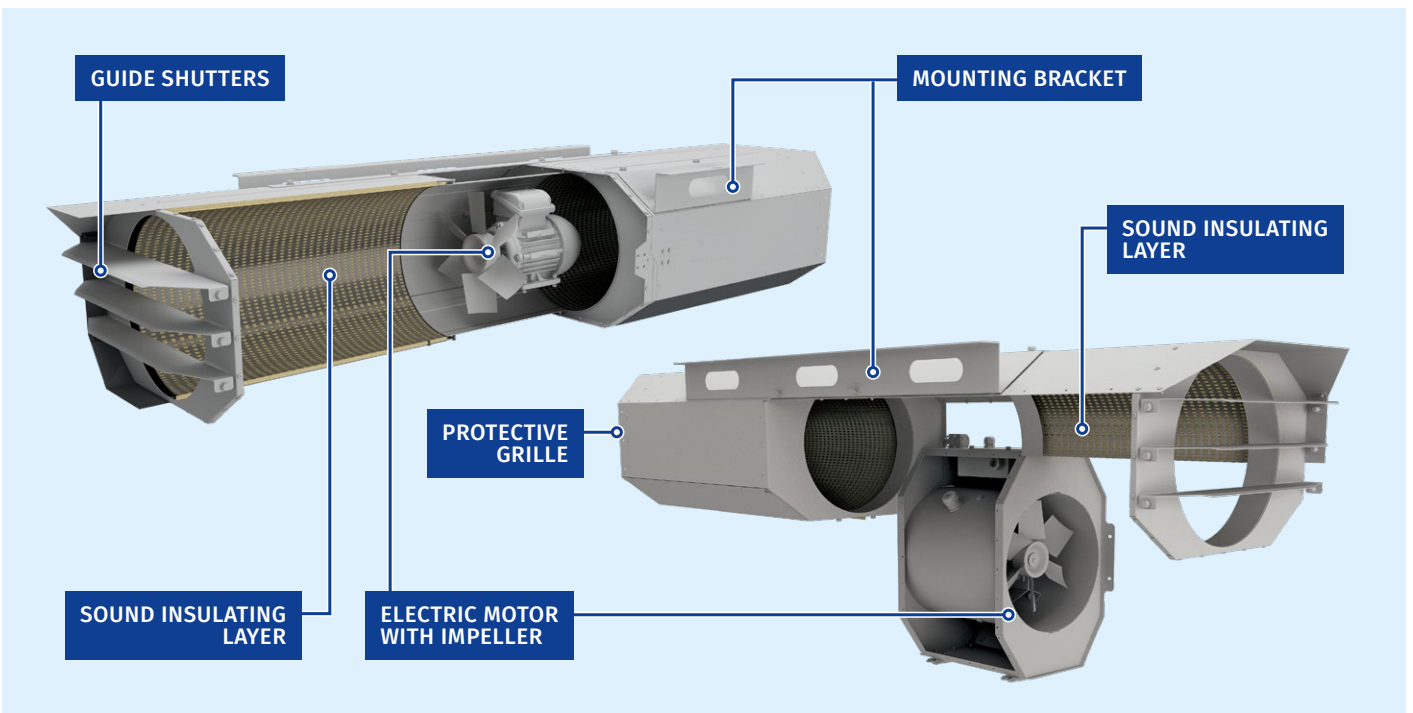

Centro-Jet induction centrifugal fan design

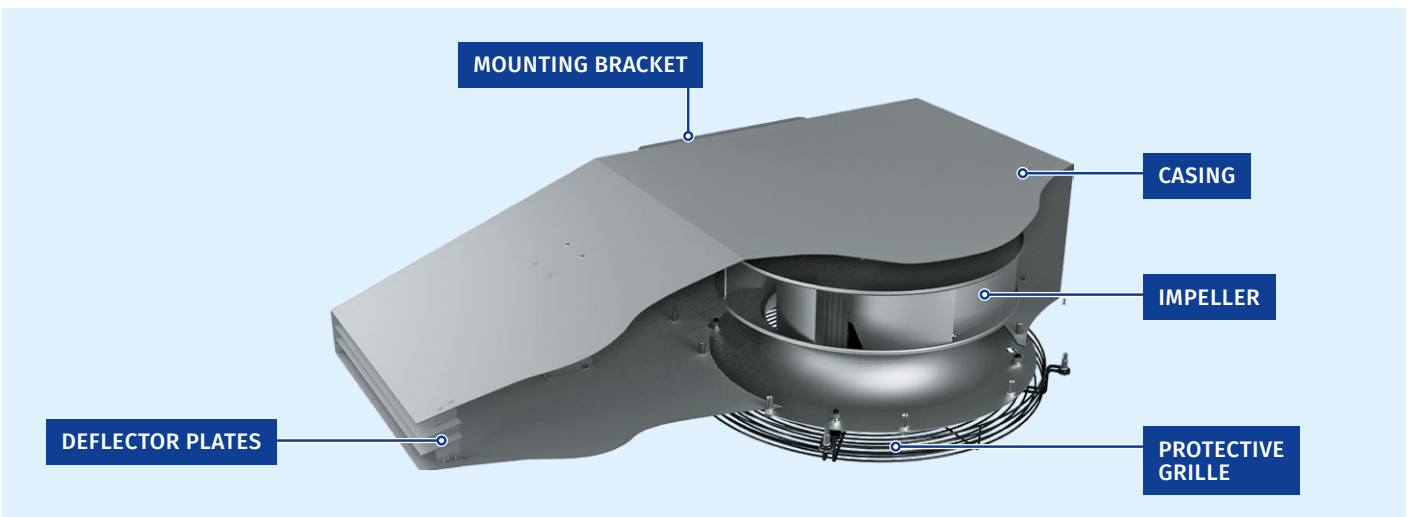

AXIS-JET

Jet axial fans

Use

- The **Axis-Jet** axial fans are designed for general purpose ventilation of underground and semiopened parkings, ventilation of tunnels, smoke extraction in case of fire as a part of smoke extract system. The fans generate a high-speed and high-pressure directed air jet.
- Temperatures of the transported medium: in continuous operation up to +55 °C; in smoke extraction mode: 300 °C/2 hrs and 400 °C/2 hrs
- Functionality. Power. Efficiency.

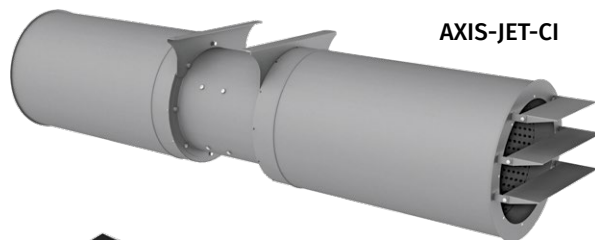

AXIS-JET-CI

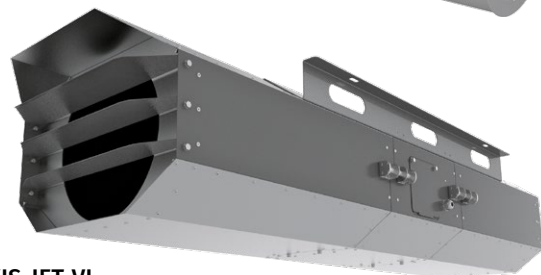

AXIS-JET-VI

Design

- The casing of the **Axis-Jet** fan is made of polymer coated steel. The fans are available in two casing versions: cylindrical and octagonal.
- The casing includes inner brackets for motor fixation. These brackets act as directing vanes and distribute air flow uniformly, thus increasing aerodynamic performances of the fan. The fan has a sound insulation of mineral wool.
- The fan in an octagonal casing **Axis-Jet-VI** has a reduced height, a hinged hatch for electrical installation with captive bolts and a detachable middle part for maintenance.

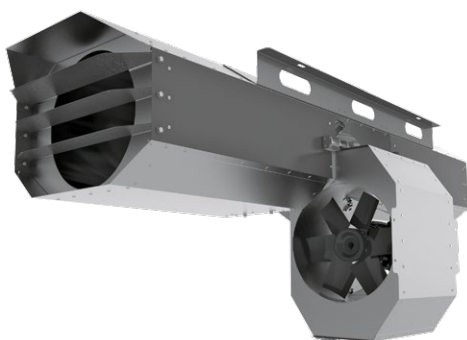

Motor

- Three-phase asynchronous short-circuit rotor motor is installed inside the fan casing. Motor ingress protection rating is IP55. The motor design ensures operation of the fan in the smoke extract systems and/or general ventilation systems in unidirectional and reversible modes. The motors are designed for 400 V mains voltage and 60 Hz mains frequency.

Impeller

- The dynamically balanced impeller is made of cast aluminium alloy (for fans of smoke extraction systems) or of glass-fiber reinforced polyamide (for fans of general industrial use).
- The reversible fans are equipped with 100 % reversible two-directional impeller.

Mounting

- The **Axis-Jet** fans are designed for horizontal ceiling mounting and fixation by means of the supplied fixing brackets attached to the fan casing.

Modifications

- Unidirectional single-speed type (U)
- Unidirectional double-speed type (U)
- Reversible single-speed (R)
- Reversible double-speed (R)

The fans with the fire resistance rating 200 °C/2 hrs can be manufactured on special request.

Designation key

| Model | Casing type | Casing insulation | Diameter [mm] | Motor | Number of poles | Air flow | Fire resistance limit/hrs | Frequency |
|-----------------------------------|--|---|--|---|---|--|--|-----------------------------------|
| AXIS-JET: jet axial fan | - C: round V: octagonal | _: without sound-insulation I: sound-insulated casing | - 315; 355; 400; 450; 500; 560; 630 | _: standard motor M, S: model with a high-power motor | - 2 2/4 (applicable for double-speed motors) | - U: unidirectional R: reversible | - _: max. +55 °C 300/2: 300 °C/2 h 400/2: 400 °C/2 h | - _: 50 Hz 60 Hz: 60 Hz |

Overall dimensions [mm]

AXIS-JET-CI

| Model | Ø D1 | A | B | H | L1 | L2 | Weight [kg] |
|-----------------------|------|-----|-----|-----|------|------|-------------|
| Unidirectional | | | | | | | |
| Axis-Jet-CI-315-U | 414 | 302 | 355 | 425 | 1654 | 1763 | 40 |
| Axis-Jet-CI-355-U | 467 | 302 | 420 | 482 | 1954 | 2079 | 50 |
| Axis-Jet-CI-400-U | 515 | 351 | 460 | 525 | 2004 | 2129 | 65 |
| Axis-Jet-CI-450-U | 565 | 351 | 500 | 575 | 2004 | 2129 | 85 |
| Axis-Jet-CI-500-U | 603 | 371 | 580 | 620 | 2004 | 2145 | 110 |
| Axis-Jet-CI-560-U | 663 | 446 | 620 | 678 | 2093 | 2247 | 155 |
| Axis-Jet-CI-630-U | 733 | 550 | 710 | 748 | 2193 | 2357 | 245 |
| Reversible | | | | | | | |
| Axis-Jet-CI-315-R | 414 | 302 | 355 | 425 | 1654 | 1872 | 40 |
| Axis-Jet-CI-355-R | 467 | 302 | 420 | 482 | 1954 | 2202 | 50 |
| Axis-Jet-CI-400-R | 515 | 351 | 460 | 525 | 2004 | 2253 | 65 |
| Axis-Jet-CI-450-R | 565 | 351 | 500 | 575 | 2004 | 2253 | 85 |
| Axis-Jet-CI-500-R | 603 | 371 | 580 | 620 | 2004 | 2290 | 110 |
| Axis-Jet-CI-560-R | 663 | 446 | 620 | 678 | 2093 | 2400 | 155 |
| Axis-Jet-CI-630-R | 733 | 550 | 710 | 748 | 2193 | 2520 | 245 |

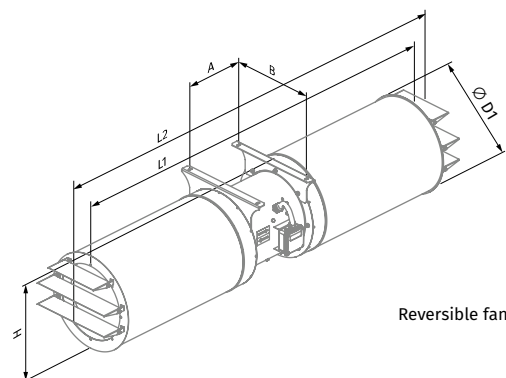
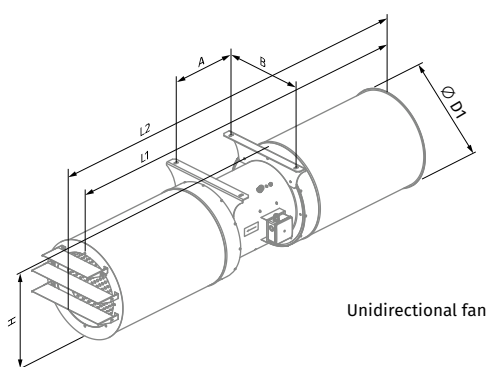

AXIS-JET-VI

| Model | Ø D1 | A | B | H | L | L1 | L2 | Weight [kg] |
|-----------------------|------|-----|-----|-----|------|-----|-----|-------------|
| Unidirectional | | | | | | | | |
| Axis-Jet-VI-315-U | 315 | 700 | 542 | 347 | 1846 | 507 | 572 | 58 |
| Axis-Jet-VI-355-U | 355 | 700 | 583 | 388 | 2046 | 546 | 613 | 75 |
| Axis-Jet-VI-400-U | 400 | 750 | 632 | 434 | 2296 | 590 | 667 | 95 |
| Reversible | | | | | | | | |
| Axis-Jet-VI-315-R | 315 | 700 | 542 | 347 | 1846 | 507 | 572 | 58 |
| Axis-Jet-VI-355-R | 355 | 700 | 583 | 388 | 2046 | 546 | 613 | 75 |
| Axis-Jet-VI-400-R | 400 | 750 | 632 | 434 | 2296 | 590 | 667 | 95 |

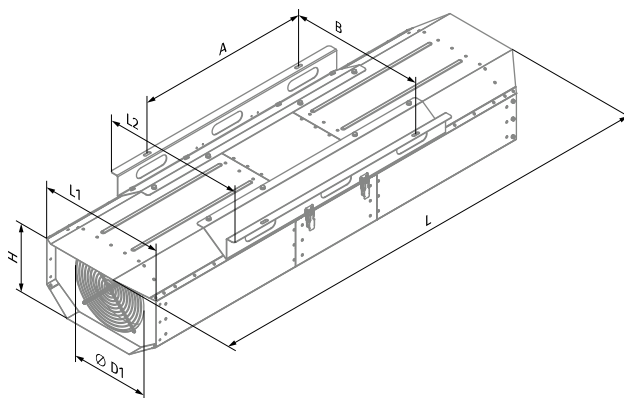

Technical data

AXIS-JET-CI

| ∅ [mm] | Air flow direction | Number of speeds | Model | Power [kW] | Max. air flow [m³/h] | Fan pull [N] | Air speed [m/s] | RPM | Operating temperature [°C] | Sound pressure LpA, dB in 3 m |
|------------------------------------|------------------------------------|----------------------------------|---------------------------------|------------|----------------------|--------------|-----------------|----------|----------------------------|-------------------------------|
| 315 | Unidirectional | 1 | Axis-Jet-CI-315-2-U-60 Hz | 0.55 | 4110 | 22 | 15.6 | 3460 | 55 °C | 70.3 |
| | | | Axis-Jet-CI-315-2-U-300/2-60 Hz | | 3090 | 13 | 11.7 | | 300 °C/2 h* | |
| | | | Axis-Jet-CI-315-2-U-400/2-60 Hz | | | | | | 400 °C/2 h* | |
| | | Axis-Jet-CI-315M-2-U-60 Hz | 0.75 | 4770 | | | | 29 | 18.1 | 55 °C |
| | | Axis-Jet-CI-315M-2-U-300/2-60 Hz | | 3500 | 16 | 13.3 | 300 °C/2 h* | 66.1 | | |
| | | Axis-Jet-CI-315M-2-U-400/2-60 Hz | | | | | 400 °C/2 h* | 66.3 | | |
| | Axis-Jet-CI-315-2/4-U-60 Hz | 0.55/0.11 | 4110/2055 | | | | 22/6 | 15.6/7.8 | 55 °C | |
| | Axis-Jet-CI-315-2/4-U-300/2-60 Hz | | 3090/1545 | 13/4 | 11.7/5.85 | 300 °C/2 h* | 70.3/55.2 | | | |
| | Axis-Jet-CI-315-2/4-U-400/2-60 Hz | | | | | 400 °C/2 h* | 66/50.9 | | | |
| | Axis-Jet-CI-315M-2/4-U-60 Hz | 0.8/0.2 | | | | 4770/2385 | 29/8 | 18.1/9 | 55 °C | |
| | Axis-Jet-CI-315M-2/4-U-300/2-60 Hz | | 3500/1750 | 16/4 | 13.3/6.65 | 300 °C/2 h* | 66.1/51 | | | |
| | Axis-Jet-CI-315M-2/4-U-400/2-60 Hz | | | | | 400 °C/2 h* | 66.3/51.2 | | | |
| | Axis-Jet-CI-315-2-R-60 Hz | 0.55 | | | | 4010 | 21 | 15.2 | 55 °C | |
| | Axis-Jet-CI-315-2-R-300/2-60 Hz | | 3460 | 11 | 11.2 | 300 °C/2 h* | 69.1 | | | |
| | Axis-Jet-CI-315-2-R-400/2-60 Hz | | | | | 400 °C/2 h* | 69.3 | | | |
| Axis-Jet-CI-315-2/4-R-60 Hz | 0.55/0.11 | 4010/2005 | | | | 21/6 | 15.2/7.6 | 55 °C | | |
| Axis-Jet-CI-315-2/4-R-300/2-60 Hz | | 3460/1730 | 11/3 | 11.2/5.6 | 300 °C/2 h* | 69.1/54 | | | | |
| Axis-Jet-CI-315-2/4-R-400/2-60 Hz | | | | | 400 °C/2 h* | 69.3/54.2 | | | | |
| Axis-Jet-CI-355-2-U-60 Hz | 0.75 | | | | 5930 | 35 | 17.6 | 55 °C | | |
| Axis-Jet-CI-355-2-U-300/2-60 Hz | | 4350 | 19 | 12.9 | 300 °C/2 h* | 65.3 | | | | |
| Axis-Jet-CI-355-2-U-400/2-60 Hz | | | | | 400 °C/2 h* | 66.4 | | | | |
| Axis-Jet-CI-355M-2-U-60 Hz | 1.1 | | | | 6560 | 43 | 19.5 | 55 °C | | |
| Axis-Jet-CI-355M-2-U-300/2-60 Hz | | 5170 | 27 | 15.4 | 300 °C/2 h* | 67.1 | | | | |
| Axis-Jet-CI-355M-2-U-400/2-60 Hz | | | | | 400 °C/2 h* | 68 | | | | |
| Axis-Jet-CI-355-2/4-U-60 Hz | 0.8/0.2 | | | | 5930/2965 | 35/9 | 17.6/8.8 | 55 °C | | |
| Axis-Jet-CI-355-2/4-U-300/2-60 Hz | | 4350/2175 | 19/5 | 12.9/6.45 | 300 °C/2 h* | 65.3/50.2 | | | | |
| Axis-Jet-CI-355-2/4-U-400/2-60 Hz | | | | | 400 °C/2 h* | 66.4/51.2 | | | | |
| Axis-Jet-CI-355M-2/4-U-60 Hz | 1.1/0.25 | | | | 6560/3280 | 43/11 | 19.5/9.75 | 55 °C | | |
| Axis-Jet-CI-355M-2/4-U-300/2-60 Hz | | 5170/2585 | 27/7 | 15.4/7.7 | 300 °C/2 h* | 67.1/52.1 | | | | |
| Axis-Jet-CI-355M-2/4-U-400/2-60 Hz | | | | | 400 °C/2 h* | 68/53 | | | | |
| Axis-Jet-CI-355-2-R-60 Hz | 1.1 | | | | 5550 | 31 | 16.5 | 55 °C | | |
| Axis-Jet-CI-355-2-R-300/2-60 Hz | | 3460 | 18 | 12.4 | 300 °C/2 h* | 71.5 | | | | |
| Axis-Jet-CI-355-2-R-400/2-60 Hz | | | | | 400 °C/2 h* | 71.8 | | | | |
| Axis-Jet-CI-355-2/4-R-60 Hz | 1.1/0.25 | | | | 5550/2775 | 31/8 | 16.5/8.25 | 55 °C | | |
| Axis-Jet-CI-355-2/4-R-300/2-60 Hz | | 3460/1730 | 18/5 | 12.4/6.2 | 300 °C/2 h* | 71.5/56.5 | | | | |
| Axis-Jet-CI-355-2/4-R-400/2-60 Hz | | | | | 400 °C/2 h* | 71.8/56.8 | | | | |
| Axis-Jet-CI-400-2-U-60 Hz | 1.1 | | | | 7810 | 48 | 18.3 | 55 °C | | |
| Axis-Jet-CI-400-2-U-300/2-60 Hz | | 7080 | 40 | 16.6 | 300 °C/2 h* | 70.8 | | | | |
| Axis-Jet-CI-400-2-U-400/2-60 Hz | | | | | 400 °C/2 h* | 67.6 | | | | |
| Axis-Jet-CI-400M-2-U-60 Hz | 2.2 | | | | 9570 | 72 | 22.5 | 55 °C | | |
| Axis-Jet-CI-400M-2-U-300/2-60 Hz | | 9320 | 69 | 21.9 | 300 °C/2 h* | 70.9 | | | | |
| Axis-Jet-CI-400M-2-U-400/2-60 Hz | | | | | 400 °C/2 h* | 69.5 | | | | |
| Axis-Jet-CI-400-2/4-U-60 Hz | 1.1/0.25 | | | | 7810/3905 | 48/12 | 18.3/9.15 | 55 °C | | |
| Axis-Jet-CI-400-2/4-U-300/2-60 Hz | | 7080/3540 | 40/10 | 16.6/8.3 | 300 °C/2 h* | 70.8/55.7 | | | | |
| Axis-Jet-CI-400-2/4-U-400/2-60 Hz | | | | | 400 °C/2 h* | 67.6/54 | | | | |
| Axis-Jet-CI-400M-2/4-U-60 Hz | 2.2/0.5 | | | | 9570/4785 | 72/18 | 22.5/11.25 | 55 °C | | |
| Axis-Jet-CI-400M-2/4-U-300/2-60 Hz | | 9320/4660 | 69/18 | 21.9/10.95 | 300 °C/2 h* | 70.9/55.9 | | | | |
| Axis-Jet-CI-400M-2/4-U-400/2-60 Hz | | | | | 400 °C/2 h* | 69.5/54.4 | | | | |
| Axis-Jet-CI-400-2-R-60 Hz | 1.5 | | | | 8040 | 51 | 18.9 | 55 °C | | |
| Axis-Jet-CI-400-2-R-300/2-60 Hz | | 7040 | 39 | 16.5 | 300 °C/2 h* | 73.9 | | | | |
| Axis-Jet-CI-400-2-R-400/2-60 Hz | | | | | 400 °C/2 h* | 71.7 | | | | |
| Axis-Jet-CI-400-2/4-R-60 Hz | 1.5/0.37 | | | | 8040/4020 | 51/13 | 18.9/9.45 | 55 °C | | |
| Axis-Jet-CI-400-2/4-R-300/2-60 Hz | | 3460/1730 | 39/10 | 16.5/8.25 | 300 °C/2 h* | 73.9/58.9 | | | | |
| Axis-Jet-CI-400-2/4-R-400/2-60 Hz | | | | | 400 °C/2 h* | 71.7/56.1 | | | | |

*Smoke extraction mode: once for two hours

AXIS-JET-CI

| Ø [mm] | Air flow direction | Number of speeds | Model | Power [kW] | Max. air flow [m³/h] | Fan pull [N] | Air speed [m/s] | RPM | Operating temperature [°C] | Sound pressure LpA, dB in 3 m | | | | | | |
|------------------------------------|------------------------------------|------------------------------------|------------------------------------|------------------------------------|----------------------|--------------|-----------------|-------------|----------------------------|-------------------------------|-------------|-------------|-------------|-----------|-------------|------|
| 450 | Unidirectional | 1 | Axis-Jet-CI-450-2-U-60 Hz | 1.5 | 10500 | 69 | 19.5 | 3460 | 55 °C | 72.1 | | | | | | |
| | | | Axis-Jet-CI-450-2-U-300/2-60 Hz | | | | | | 300 °C/2 h* | | | | | | | |
| | | | Axis-Jet-CI-450-2-U-450/2-60 Hz | | | | | | 400 °C/2 h* | | | | | | | |
| | | 2 | Axis-Jet-CI-450M-2-U-60 Hz | 2.2 | 12500 | 97 | 23.2 | 3460 | 55 °C | 71.2 | | | | | | |
| | | | Axis-Jet-CI-450M-2-U-300/2-60 Hz | | | | | | 300 °C/2 h* | | | | | | | |
| | | | Axis-Jet-CI-450M-2-U-400/2-60 Hz | | | | | | 400 °C/2 h* | | | | | | | |
| | | 3 | Axis-Jet-CI-450S-2-U-60 Hz | 3 | 13300 | 110 | 24.6 | 3460 | 55 °C | 74.3 | | | | | | |
| | | | Axis-Jet-CI-450S-2-U-300/2-60 Hz | | | | | | 300 °C/2 h* | | | | | | | |
| | | | Axis-Jet-CI-450S-2-U-400/2-60 Hz | | | | | | 400 °C/2 h* | | | | | | | |
| | | Reversible | 1 | Axis-Jet-CI-450-2/4-U-60 Hz | 1.5/0.37 | 10500/5250 | 69/18 | 19.5/9.75 | 3460/1730 | 55 °C | 72.1/57 | | | | | |
| | | | | Axis-Jet-CI-450-2/4-U-300/2-60 Hz | | | | | | 300 °C/2 h* | | | | | | |
| | | | | Axis-Jet-CI-450-2/4-U-400/2-60 Hz | | | | | | 400 °C/2 h* | | | | | | |
| | Axis-Jet-CI-450M-2/4-U-60 Hz | | | 9860/4930 | | | | | | 61/16 | | 18.3/9.15 | 400 °C/2 h* | 70.6/55.5 | | |
| | Axis-Jet-CI-450M-2/4-U-300/2-60 Hz | | | 12500/6250 | | | | | | 97/25 | | 23.2/11.6 | 300 °C/2 h* | 71.2/56.2 | | |
| | Axis-Jet-CI-450M-2/4-U-400/2-60 Hz | | | 11400/5700 | | | | | | 81/21 | | 21.1/10.55 | 400 °C/2 h* | 71.1/56 | | |
| | 2 | | Axis-Jet-CI-450S-2/4-U-60 Hz | 3.1/0.8 | 13300/6650 | 110/28 | 24.6/12.3 | 3460 | 55 °C | 74.3/59.2 | | | | | | |
| | | | Axis-Jet-CI-450S-2/4-U-300/2-60 Hz | | | | | | 300 °C/2 h* | | | | | | | |
| | | | Axis-Jet-CI-450S-2/4-U-400/2-60 Hz | | | | | | 400 °C/2 h* | | | | | | | |
| | | | Axis-Jet-CI-450-2-R-60 Hz | | | | | | 1.5 | | 9110 | 52 | 16.9 | 3460 | 55 °C | 79.8 |
| | | | Axis-Jet-CI-450-2-R-300/2-60 Hz | | | | | | | | | | | | 300 °C/2 h* | |
| | | | Axis-Jet-CI-450-2-R-450/2-60 Hz | | | | | | | | | | | | 400 °C/2 h* | |
| | Axis-Jet-CI-450M-2-R-60 Hz | 2.2 | 11100 | 77 | 20.6 | 3460 | 55 °C | 77.3 | | | | | | | | |
| | Axis-Jet-CI-450M-2-R-300/2-60 Hz | | | | | | 300 °C/2 h* | | | | | | | | | |
| | Axis-Jet-CI-450M-2-R-400/2-60 Hz | | | | | | 400 °C/2 h* | | | | | | | | | |
| Axis-Jet-CI-450S-2-R-60 Hz | 3 | | | | | | 12500 | | 97 | 23.1 | 3460 | 55 °C | 75.9 | | | |
| Axis-Jet-CI-450S-2-R-300/2-60 Hz | | | | | | | | | | | | 300 °C/2 h* | | | | |
| Axis-Jet-CI-450S-2-R-400/2-60 Hz | | | | | | | | | | | | 400 °C/2 h* | | | | |
| Axis-Jet-CI-450-2/4-R-60 Hz | | 1.5/0.37 | 9110/4555 | 52/13 | 16.9/8.45 | 3460/1730 | | 55 °C | | | | 79.8/64.7 | | | | |
| Axis-Jet-CI-450-2/4-R-300/2-60 Hz | | | | | | | | 300 °C/2 h* | | | | | | | | |
| Axis-Jet-CI-450-2/4-R-400/2-60 Hz | | | | | | | | 400 °C/2 h* | | | | | | | | |
| Axis-Jet-CI-450M-2/4-R-60 Hz | 2.2/0.5 | | | | | | 11100/5550 | 77/20 | 20.6/10.3 | 3460/1730 | 55 °C | | 77.3/62.3 | | | |
| Axis-Jet-CI-450M-2/4-R-300/2-60 Hz | | | | | | | | | | | 300 °C/2 h* | | | | | |
| Axis-Jet-CI-450M-2/4-R-400/2-60 Hz | | | | | | | | | | | 400 °C/2 h* | | | | | |
| Axis-Jet-CI-450S-2/4-R-60 Hz | | 3.1/0.8 | 12500/6250 | 97/25 | 23.1/11.55 | 3460 | | | | | 55 °C | 75.9/60.9 | | | | |
| Axis-Jet-CI-450S-2/4-R-300/2-60 Hz | | | | | | | | | | | 300 °C/2 h* | | | | | |
| Axis-Jet-CI-450S-2/4-R-400/2-60 Hz | | | | | | | | | | | 400 °C/2 h* | | | | | |
| Axis-Jet-CI-500-2/4-U-60 Hz | 3.1/0.8 | | | | | | 14100/7030 | 100/25 | 21.1/10.5 | 3460/1730 | 55 °C | | 78.2/63.1 | | | |
| Axis-Jet-CI-500-2/4-U-300/2-60 Hz | | | | | | | | | | | 300 °C/2 h* | | | | | |
| Axis-Jet-CI-500-2/4-U-400/2-60 Hz | | | | | | | | | | | 400 °C/2 h* | | | | | |
| 500 | Unidirectional | 2 | Axis-Jet-CI-500M-2/4-U-60 Hz | 4.4/1.1 | 17300/8630 | 149/38 | 25.8/12.9 | 3460/1730 | 55 °C | 76.8/61.8 | | | | | | |
| | | | Axis-Jet-CI-500M-2/4-U-300/2-60 Hz | | | | | | 300 °C/2 h* | | | | | | | |
| | | | Axis-Jet-CI-500M-2/4-U-400/2-60 Hz | | | | | | 400 °C/2 h* | | | | | | | |
| | | Reversible | 1 | Axis-Jet-CI-500-2/4-R-60 Hz | 3.1/0.8 | 14900/7460 | 111/28 | 22.3/11.2 | 3460 | 55 °C | 77/61.9 | | | | | |
| | | | | Axis-Jet-CI-500-2/4-R-300/2-60 Hz | | | | | | 300 °C/2 h* | | | | | | |
| | | | | Axis-Jet-CI-500-2/4-R-400/2-60 Hz | | | | | | 400 °C/2 h* | | | | | | |
| | 2 | | Axis-Jet-CI-500M-2/4-R-60 Hz | 4.4/1.1 | 16400/8160 | 134/34 | 24.5/12.3 | 3460 | 55 °C | 78.6/63.5 | | | | | | |
| | | | Axis-Jet-CI-500M-2/4-R-300/2-60 Hz | | | | | | 300 °C/2 h* | | | | | | | |
| | | | Axis-Jet-CI-500M-2/4-R-400/2-60 Hz | | | | | | 400 °C/2 h* | | | | | | | |
| | 560 | Unidirectional | 2 | Axis-Jet-CI-560-2/4-U-60 Hz | 4.4/1.1 | 19600/9790 | 157/40 | 23.9/12 | 3460/1730 | 55 °C | 76.8/61.8 | | | | | |
| | | | | Axis-Jet-CI-560-2/4-U-300/2-60 Hz | | | | | | 300 °C/2 h* | | | | | | |
| | | | | Axis-Jet-CI-560-2/4-U-400/2-60 Hz | | | | | | 400 °C/2 h* | | | | | | |
| Reversible | | | 1 | Axis-Jet-CI-560M-2/4-U-60 Hz | 8/2 | 24500/12300 | 245/62 | 30/15 | 3530/1765 | 55 °C | 78.4/63.4 | | | | | |
| | | | | Axis-Jet-CI-560M-2/4-U-300/2-60 Hz | | | | | | 300 °C/2 h* | | | | | | |
| | | | | Axis-Jet-CI-560M-2/4-U-400/2-60 Hz | | | | | | 400 °C/2 h* | | | | | | |
| | | 2 | Axis-Jet-CI-560-2/4-R-60 Hz | 4.4/1.1 | 18100/9030 | 134/34 | 22.1/11 | 3460/1730 | 55 °C | 82.4/67.3 | | | | | | |
| | | | Axis-Jet-CI-560-2/4-R-300/2-60 Hz | | | | | | 300 °C/2 h* | | | | | | | |
| | | | Axis-Jet-CI-560-2/4-R-400/2-60 Hz | | | | | | 400 °C/2 h* | | | | | | | |
| 3 | | Axis-Jet-CI-560M-2/4-R-60 Hz | 6/1.5 | 20600/10300 | 174/44 | 25.2/12.6 | 3530/1765 | 55 °C | 81.4/66.4 | | | | | | | |
| | | Axis-Jet-CI-560M-2/4-R-300/2-60 Hz | | | | | | 300 °C/2 h* | | | | | | | | |
| | | Axis-Jet-CI-560M-2/4-R-400/2-60 Hz | | | | | | 400 °C/2 h* | | | | | | | | |

*Smoke extraction mode: once for two hours

AXIS-JET-CI

| ∅ [mm] | Air flow direction | Number of speeds | Model | Power [kW] | Max. air flow [m³/h] | Fan pull [N] | Air speed [m/s] | RPM | Operating temperature [°C] | Sound pressure LpA, dB in 3 m | | | |
|--------|--------------------|------------------|------------------------------------|-------------|----------------------|--------------|-----------------|-----------|----------------------------|-------------------------------|-----------|-------------|-------------|
| 630 | Unidirectional | 2 | Axis-Jet-CI-630-2/4-U-60 Hz | 12/3 | 31700/15800 | 324/81 | 30.6/15.3 | 3530/1765 | 55 °C | 83.2/68.2 | | | |
| | | | Axis-Jet-CI-630-2/4-U-300/2-60 Hz | | | | | | 30600/15300 | 301/75 | 29.5/14.7 | 300 °C/2 h* | 81.6/66.6 |
| | | | Axis-Jet-CI-630-2/4-U-400/2-60 Hz | | | | | | 36500/18200 | 429/107 | 35.2/17.6 | 400 °C/2 h* | 82.7/67.6 |
| | | | Axis-Jet-CI-630M-2/4-U-60 Hz | 16/4 | 35000/17500 | 395/99 | 33.8/16.9 | | | | | 300 °C/2 h* | 81.1/66 |
| | | | Axis-Jet-CI-630M-2/4-U-300/2-60 Hz | | | | | | 30600/15300 | 302/76 | 29.6/14.8 | 55 °C | 85.7/70.6 |
| | Reversible | 2 | Axis-Jet-CI-630-2/4-R-60 Hz | 12/3 | 29400/14700 | 279/70 | 28.4/14.2 | 3530/1765 | 300 °C/2 h* | 84.1/69 | | | |
| | | | Axis-Jet-CI-630-2/4-R-300/2-60 Hz | | | | | | 32400/16200 | 339/85 | 31.3/15.7 | 400 °C/2 h* | 86.4/71.4 |
| | | | Axis-Jet-CI-630M-2/4-R-60 Hz | | | | | | | | | 16/4 | 30800/15400 |
| | | | Axis-Jet-CI-630M-2/4-R-300/2-60 Hz | 30800/15400 | 305/76 | 29.7/14.8 | 300 °C/2 h* | | 85.7/70.6 | | | | |
| | | | Axis-Jet-CI-630M-2/4-R-400/2-60 Hz | 400 °C/2 h* | | | | | | | | | |

*Smoke extraction mode: once for two hours

AXIS-JET-VI

| Ø [mm] | Air flow direction | Number of speeds | Model | Power [kW] | Max. air flow [m³/h] | Fan pull [N] | Air speed [m/s] | RPM | Operating temperature [°C] | Sound pressure LpA, dB in 3 m |
|----------|-----------------------------------|------------------|------------------------------------|-----------------------------------|----------------------|--------------|-----------------|-------------|----------------------------|-------------------------------|
| 315 | Unidirectional | 1 | Axis-Jet-VI-315-2-U-60 Hz | 0.55 | 4110 | 22 | 15.6 | 3460 | 55 °C | 70.3 |
| | | | Axis-Jet-VI-315-2-U-300/2-60 Hz | | 3090 | 13 | 11.7 | | 300 °C/2 h* | |
| | | | Axis-Jet-VI-315-2-U-400/2-60 Hz | | 3090 | 13 | 11.7 | | 400 °C/2 h* | |
| | | 2 | 0.75 | Axis-Jet-VI-315M-2-U-60 Hz | 4770 | 29 | 18.1 | 55 °C | 66.1 | |
| | | | | Axis-Jet-VI-315M-2-U-300/2-60 Hz | 3500 | 16 | 13.3 | 300 °C/2 h* | 66.3 | |
| | | | | Axis-Jet-VI-315-2/4-U-60 Hz | 4110/2055 | 22/6 | 15.6/7.8 | 55 °C | 70.3/55.2 | |
| | 0.55/0.11 | | Axis-Jet-VI-315-2/4-U-300/2-60 Hz | 3090/1545 | 13/4 | 11.7/5.85 | 300 °C/2 h* | 66/50.9 | | |
| | | | Axis-Jet-VI-315M-2/4-U-60 Hz | 4770/2385 | 29/8 | 18.1/9 | 55 °C | 66.1/51 | | |
| | | | Axis-Jet-VI-315M-2/4-U-300/2-60 Hz | 3500/1750 | 16/4 | 13.3/6.65 | 300 °C/2 h* | 66.3/51.2 | | |
| | Reversible | 1 | Axis-Jet-VI-315-2-R-60 Hz | 0.55 | 4010 | 21 | 15.2 | 3460 | 55 °C | 69.1 |
| | | | Axis-Jet-VI-315-2-R-300/2-60 Hz | | 2940 | 11 | 11.2 | | 300 °C/2 h* | |
| | | | Axis-Jet-VI-315-2-R-400/2-60 Hz | | 2940 | 11 | 11.2 | | 400 °C/2 h* | |
| | | 2 | 0.55/0.11 | Axis-Jet-VI-315-2/4-R-60 Hz | 4010/2005 | 21/6 | 15.2/7.6 | 55 °C | 69.1/54 | |
| | | | | Axis-Jet-VI-315-2/4-R-300/2-60 Hz | 2940/1470 | 11/3 | 11.2/5.6 | 300 °C/2 h* | 69.3/54.2 | |
| | | | | Axis-Jet-VI-315-2/4-R-400/2-60 Hz | 2940/1470 | 11/3 | 11.2/5.6 | 400 °C/2 h* | 69.3/54.2 | |
| 355 | Unidirectional | 1 | Axis-Jet-VI-355-2-U-60 Hz | 0.75 | 5930 | 35 | 17.6 | 3460 | 55 °C | 65.3 |
| | | | Axis-Jet-VI-355-2-U-300/2-60 Hz | | 4350 | 19 | 12.9 | | 300 °C/2 h* | |
| | | | Axis-Jet-VI-355-2-U-400/2-60 Hz | | 4350 | 19 | 12.9 | | 400 °C/2 h* | |
| | | 2 | 1.1 | Axis-Jet-VI-355M-2-U-60 Hz | 6560 | 43 | 19.5 | 55 °C | 67.1 | |
| | | | | Axis-Jet-VI-355M-2-U-300/2-60 Hz | 5170 | 27 | 15.4 | 300 °C/2 h* | 68 | |
| | | | | Axis-Jet-VI-355-2/4-U-60 Hz | 5930/2965 | 35/9 | 17.6/8.8 | 55 °C | 65.3/50.2 | |
| | 0.8/0.2 | | Axis-Jet-VI-355-2/4-U-300/2-60 Hz | 4350/2175 | 19/5 | 12.9/6.45 | 300 °C/2 h* | 66.4/51.2 | | |
| | | | Axis-Jet-VI-355M-2/4-U-60 Hz | 6560/3280 | 43/11 | 19.5/9.75 | 55 °C | 67.1/52.1 | | |
| | | | Axis-Jet-VI-355M-2/4-U-300/2-60 Hz | 5170/2585 | 27/7 | 15.4/7.7 | 300 °C/2 h* | 68/53 | | |
| | Reversible | 1 | Axis-Jet-VI-355-2-R-60 Hz | 1.1 | 5550 | 31 | 16.5 | 3460 | 55 °C | 71.5 |
| | | | Axis-Jet-VI-355-2-R-300/2-60 Hz | | 4170 | 18 | 12.4 | | 300 °C/2 h* | |
| | | | Axis-Jet-VI-355-2-R-400/2-60 Hz | | 4170 | 18 | 12.4 | | 400 °C/2 h* | |
| | | 2 | 1.1/0.25 | Axis-Jet-VI-355-2/4-R-60 Hz | 5550/2775 | 31/8 | 16.5/8.25 | 55 °C | 71.5/56.5 | |
| | | | | Axis-Jet-VI-355-2/4-R-300/2-60 Hz | 4170/2085 | 18/5 | 12.4/6.2 | 300 °C/2 h* | 71.8/56.8 | |
| | | | | Axis-Jet-VI-355-2/4-R-400/2-60 Hz | 4170/2085 | 18/5 | 12.4/6.2 | 400 °C/2 h* | 71.8/56.8 | |
| 400 | Unidirectional | 1 | Axis-Jet-VI-400-2-U-60 Hz | 1.1 | 7810 | 48 | 18.3 | 3460 | 55 °C | 70.8 |
| | | | Axis-Jet-VI-400-2-U-300/2-60 Hz | | 7080 | 40 | 16.6 | | 300 °C/2 h* | |
| | | | Axis-Jet-VI-400-2-U-400/2-60 Hz | | 7080 | 40 | 16.6 | | 400 °C/2 h* | |
| | | 2 | 2.2 | Axis-Jet-VI-400M-2-U-60 Hz | 9570 | 72 | 22.5 | 55 °C | 70.9 | |
| | | | | Axis-Jet-VI-400M-2-U-300/2-60 Hz | 9320 | 69 | 21.9 | 300 °C/2 h* | 69.5 | |
| | | | | Axis-Jet-VI-400M-2-U-400/2-60 Hz | 9320 | 69 | 21.9 | 400 °C/2 h* | 69.5 | |
| | 1.1/0.25 | | Axis-Jet-VI-400-2/4-U-60 Hz | 7810/3905 | 48/12 | 18.3/9.15 | 55 °C | 70.8/55.7 | | |
| | | | Axis-Jet-VI-400-2/4-U-300/2-60 Hz | 7080/3540 | 40/10 | 16.6/8.3 | 300 °C/2 h* | 67.6/54 | | |
| | | | Axis-Jet-VI-400-2/4-U-400/2-60 Hz | 7080/3540 | 40/10 | 16.6/8.3 | 400 °C/2 h* | 67.6/54 | | |
| | Reversible | 1 | Axis-Jet-VI-400M-2/4-U-60 Hz | 2.2/0.5 | 9570/4785 | 72/18 | 22.5/11.25 | 3460/1730 | 55 °C | 70.9/55.9 |
| | | | Axis-Jet-VI-400M-2/4-U-300/2-60 Hz | | 9320/4660 | 69/18 | 21.9/10.95 | | 300 °C/2 h* | |
| | | | Axis-Jet-VI-400M-2/4-U-400/2-60 Hz | | 9320/4660 | 69/18 | 21.9/10.95 | | 400 °C/2 h* | |
| | | 2 | 1.5 | Axis-Jet-VI-400-2-R-60 Hz | 8040 | 51 | 18.9 | 55 °C | 73.9 | |
| | | | | Axis-Jet-VI-400-2-R-300/2-60 Hz | 7040 | 39 | 16.5 | 300 °C/2 h* | 71.7 | |
| | | | | Axis-Jet-VI-400-2-R-400/2-60 Hz | 7040 | 39 | 16.5 | 400 °C/2 h* | | |
| 1.5/0.37 | Axis-Jet-VI-400-2/4-R-60 Hz | 8040/4020 | 51/13 | 18.9/9.45 | 55 °C | 73.9/58.9 | | | | |
| | Axis-Jet-VI-400-2/4-R-300/2-60 Hz | 7040/3520 | 39/10 | 16.5/8.25 | 300 °C/2 h* | 71.7/56.1 | | | | |
| | Axis-Jet-VI-400-2/4-R-400/2-60 Hz | 7040/3520 | 39/10 | 16.5/8.25 | 400 °C/2 h* | 71.7/56.1 | | | | |

*Smoke extraction mode: once for two hours

CENTRO-JET

Induction centrifugal fans

Use

- Induction centrifugal fans **Centro-Jet** are designed for general purpose ventilation of underground and semiopened parkings, smoke extraction in case of fire as a part of smoke extract system. The fans generate a high-speed and high-pressure directed air jet.

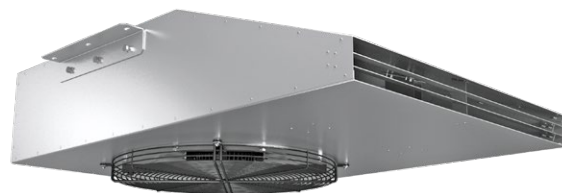

Design

- Centro-Jet casing is made of polymer coated steel.
- Due to low height of the casing the fan is recommended for use in low-ceilinged room.
- The protecting grille on the intake side prevents ingress of foreign objects into the fan.
- Deflector plates on the exhaust side of the fan ensure correct air flow distribution.

Modifications

- Single-speed
- Double-speed

Motor

- Single- or double-speed 4-, 6- or 8-pole asynchronous motors are used. The motor ingress protection rating is IP55. The motors are rated for 400 V power mains voltage and 50 Hz frequency.

Impeller

- The impeller with backward curved steel blades.

Mounting

- The Centro-Jet fans are designed for ceiling mounting and fixation by means of the supplied fixing brackets. Power is supplied through the internal terminal box. The fan wiring and mounting must be made according to the instructions and the wiring diagram shown in the terminal box.

Overall dimensions [mm]

| Model | A | B | C | H | K | Weight [kg] |
|-----------------|-----|------|------|-----|-----|-------------|
| Centro-Jet-50N | 290 | 1355 | 935 | 90 | 350 | 96 |
| Centro-Jet-85N | 330 | 1605 | 1105 | 110 | 390 | 136 |
| Centro-Jet-100N | 330 | 1605 | 1105 | 110 | 390 | 138 |

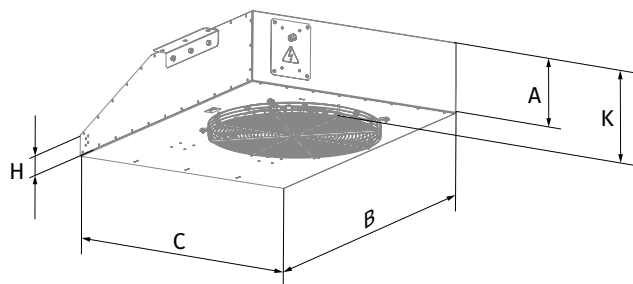

The fans with the fire resistance rating 200 °C/2 hrs can be manufactured on special request.

Designation key

| Model | Fan pull [N] | Number of poles | Fire resistance limit/hrs | Frequency |
|---|--------------|--|---|--|
| CENTRO-JET: Induction centrifugal fan | - 50N | - 4 4/6 (applicable for double-speed models) 4/8 (applicable for double-speed models) | - _: max. +55 °C 300/2: 300 °C/2 h 400/2: 400 °C/2 h | - _: 50 Hz 60 Hz: 60 Hz |

Technical data

| Model | Number of speeds | Max. air flow [m ³ /h] | Power [kW] | Fan pull [N] | Air speed [m/s] | RPM | Operating temperature [°C] | Sound pressure LpA, dB in 3 m |
|-------------------------------|------------------|-----------------------------------|------------|--------------|-----------------|-----------|----------------------------|-------------------------------|
| Centro-Jet-50N-4-60Hz | 1 | 6200 | 1.5 | 50 | 20.5 | 1500 | -25...+55 °C | 72 |
| Centro-Jet-50N-4-300/2-60Hz | | | | | | | 300 °C/2 h* | |
| Centro-Jet-50N-4-400/2-60Hz | | | | | | | 400 °C/2 h* | |
| Centro-Jet-50N-4/6-60Hz | 2 | 6200/4100 | 1.5/0.37 | 50/20 | 20.5/13.5 | 1500/1000 | -25...+55 °C | 72/59 |
| Centro-Jet-50N-4/6-300/2-60Hz | | | | | | | 300 °C/2 h* | |
| Centro-Jet-50N-4/6-400/2-60Hz | | | | | | | 400 °C/2 h* | |
| Centro-Jet-50N-4/8-60Hz | | | | | | | -25...+55 °C | |
| Centro-Jet-50N-4/8-300/2-60Hz | | | | | | | 300 °C/2 h* | |
| Centro-Jet-50N-4/8-400/2-60Hz | | | | | | | 400 °C/2 h* | |

* Smoke extraction mode: once for two hours

VENTILATION SYSTEM FOR UNDERROOF PARKING

VENTILATION SYSTEM FOR UNDERROOF PARKING

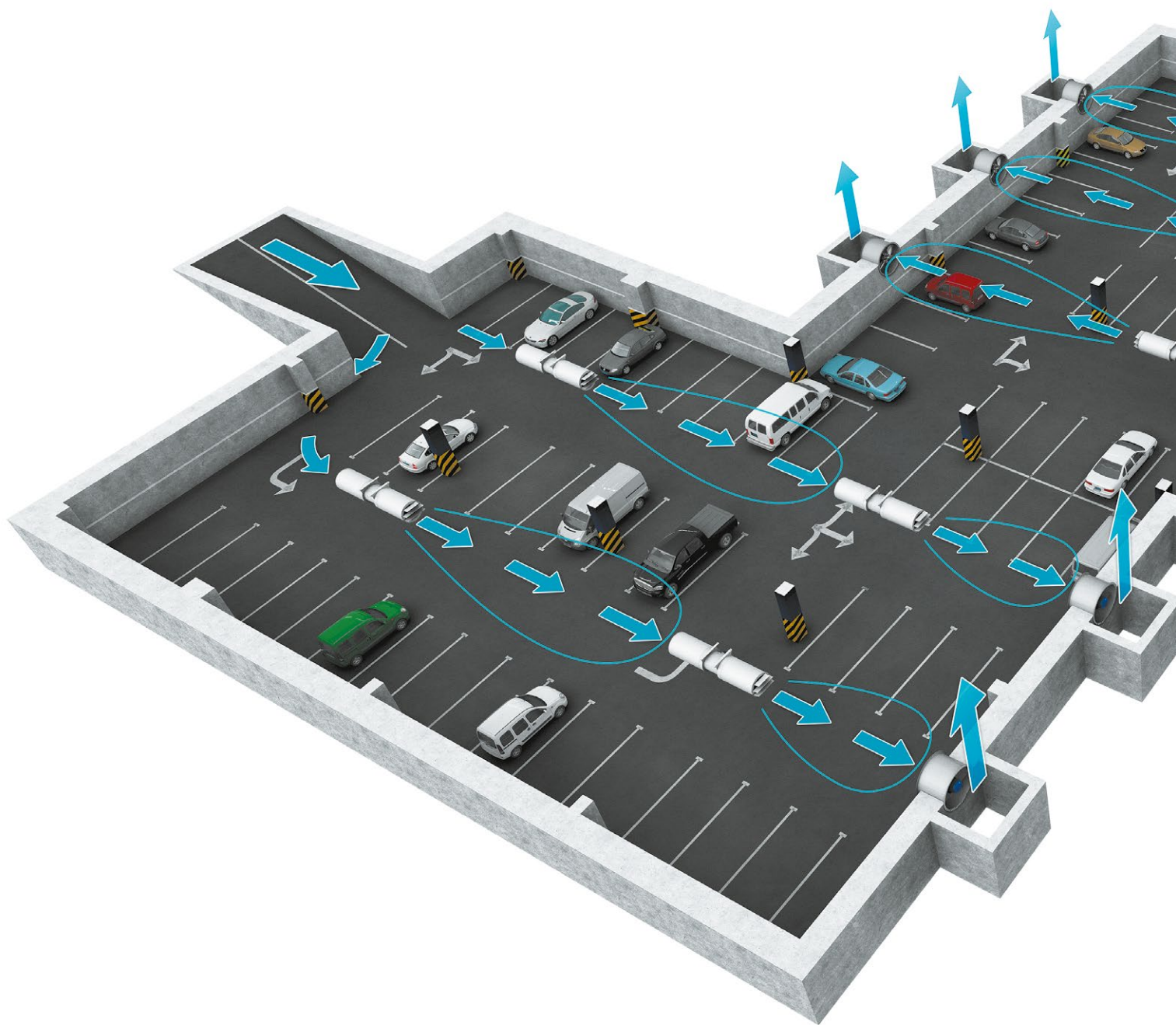

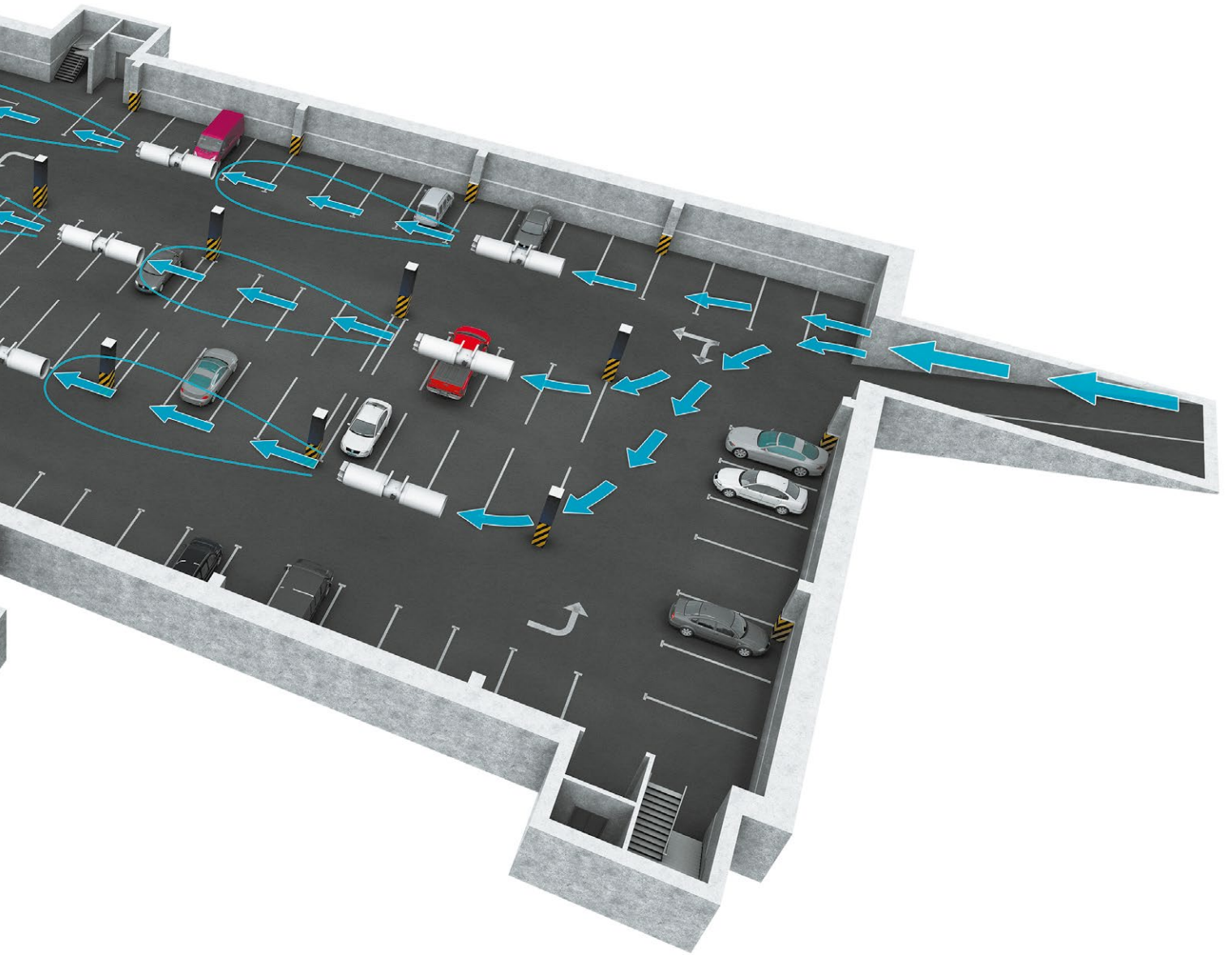

VENTILATION SYSTEM FOR UNDERROOF PARKING

SMOKE EXTRACTION SYSTEM FOR UNDERROOF PARKING

SMOKE EXTRACTION SYSTEM FOR UNDERROOF PARKING

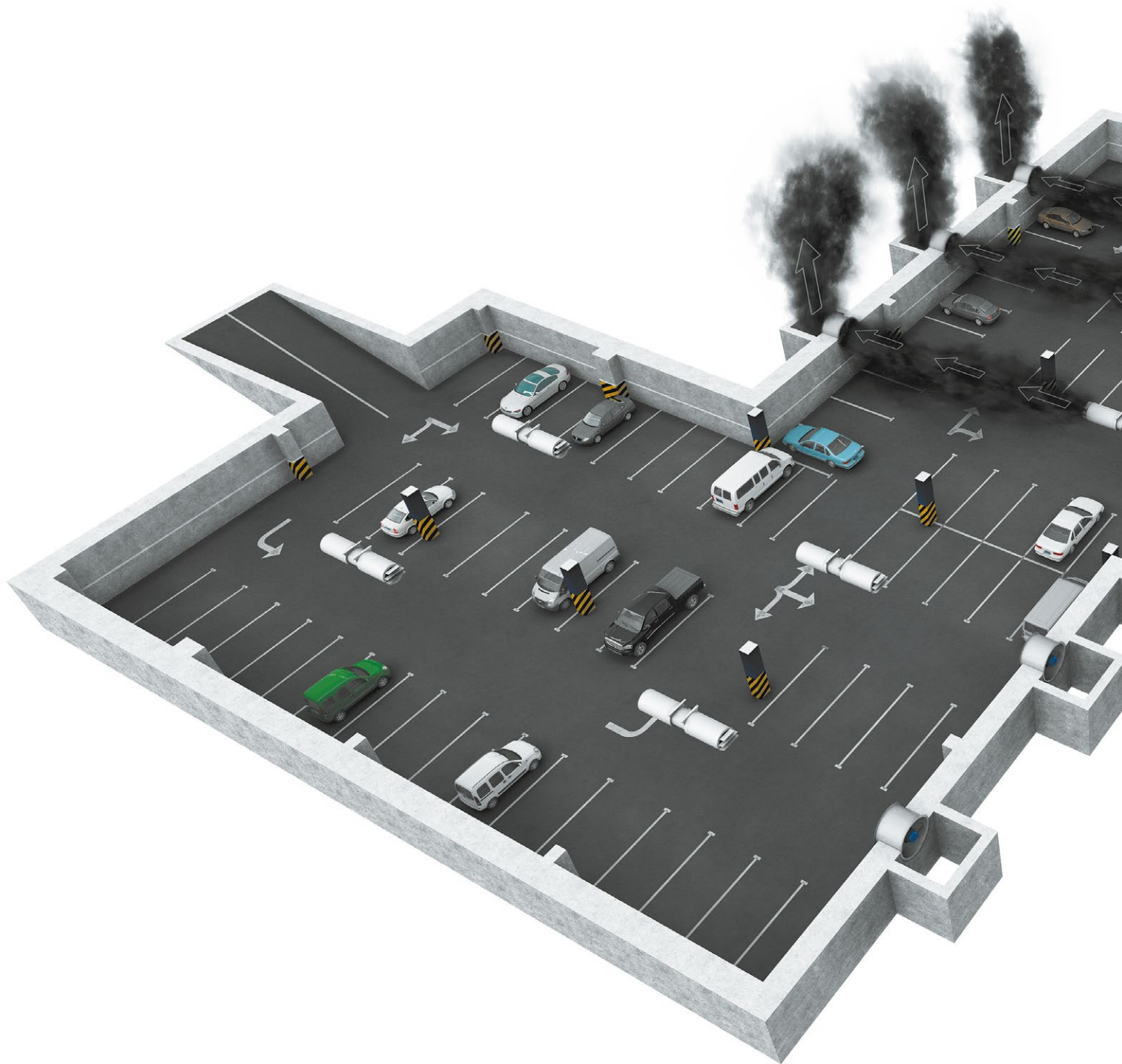

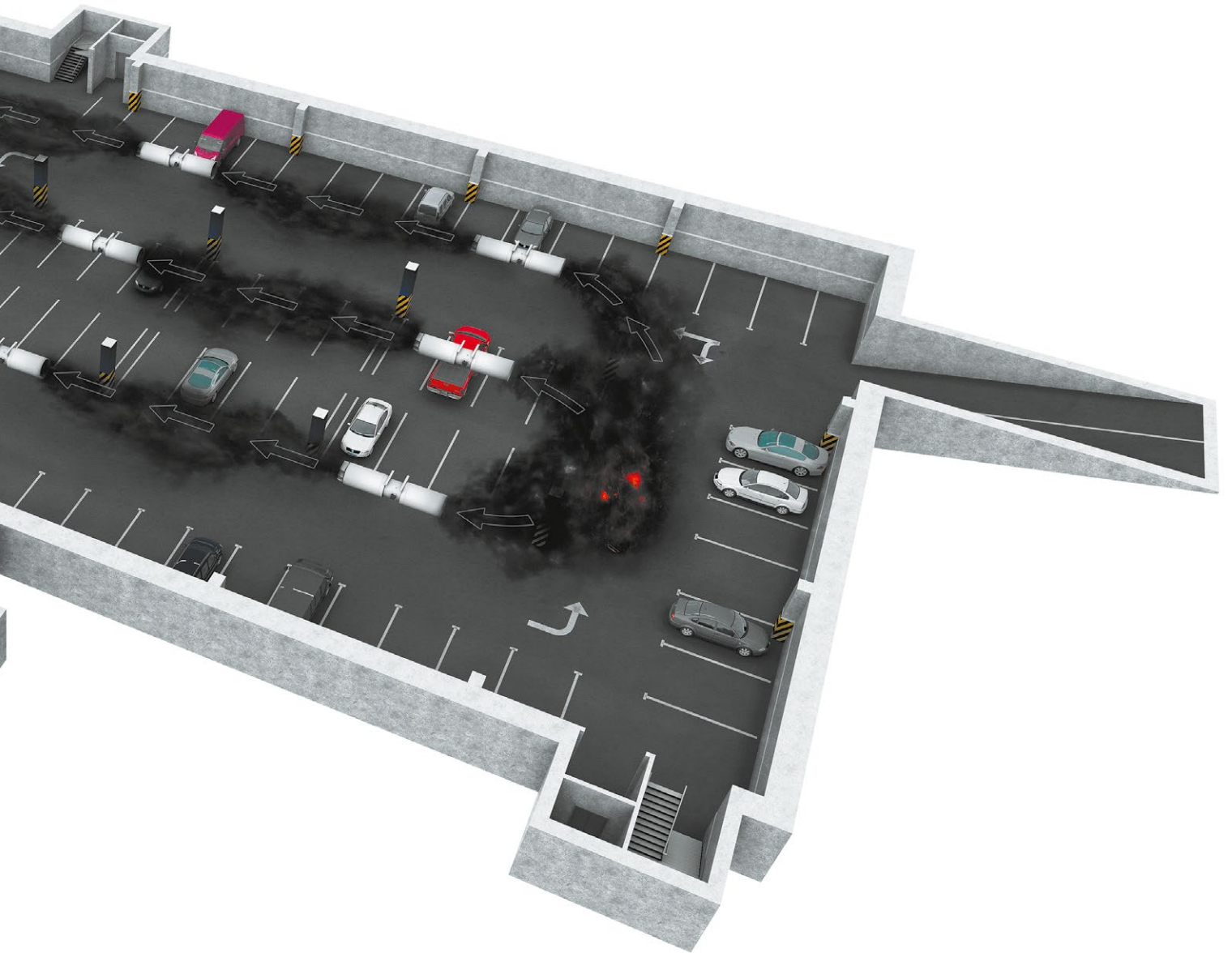

SMOKE EXTRACTION SYSTEM FOR UNDERROOF
PARKING

OPERATION OF FANS WITH FREQUENCY CONVERTERS

Ventilation systems produce a heavy load on the electrical systems of a building. Therefore, reducing the power consumption is among the top priorities for construction project designers.

DIRECT ON-LINE STARTING (DOL)

As a rule, smoke extraction systems utilize large high-performance fans. During starting the high inertia of the shaft causes a substantial increase in the start-up time – i.e. the time from the application of power to reaching the rated speed. As a result the motor is subjected to high starting current for a prolonged period of time.

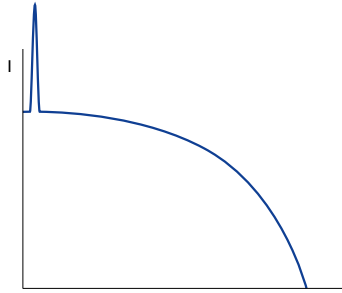

Current diagram with direct on-line starting

Standard switchgear (automatic circuit breakers, contactors and motor starters) is not designed to withstand prolonged overloads causing the fan to shut down automatically during starting.

Using switchgear with a higher maximum current rating renders the electric motor protection system less sensitive.

As a result the switchgear will not be able to detect motor overload in time due to a higher current sensing threshold.

Such challenges can only be addressed by utilizing a soft starter or a frequency converter to start the fan without causing a prolonged overload.

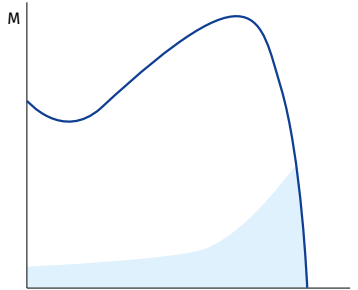

Torque diagram with direct on-line starting

FREQUENCY CONVERTER

A frequency converter (FC) consists of two main component blocks. One converts alternating current (50 or 60 Hz) into direct current.

The other converts direct current into alternating current of variable frequency ranging from 0 to 250 Hz.

By controlling the frequency output the FC offers a broad range of motor speed regulation.

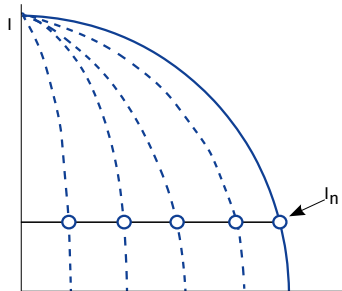

Current diagram with FC starting

During the starting the FC raises the frequency from 0 Hz to the electrical mains frequency (50 or 60 Hz).

As the frequency is increased gradually, the motor can be assumed to operate at its nominal speed for a given frequency value.

Furthermore, on the assumption that the motor runs at its nominal speed the nominal torque should be immediately available whereas the current will be approximately equal to the nominal value.

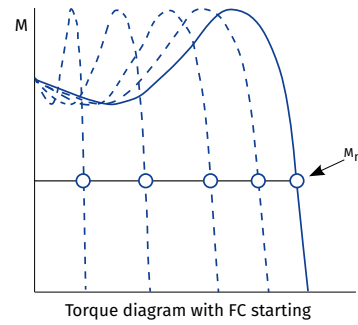

Torque diagram with FC starting

SOFT STARTER

Unlike an FC, a soft starter does not change the frequency of speed.

Instead it gradually increases the voltage supplied to the motor – from the initial level to the nominal level.

The very low voltage initially supplied to the motor during starting helps avoid sudden jolts.

Both voltage and torque increase gradually.

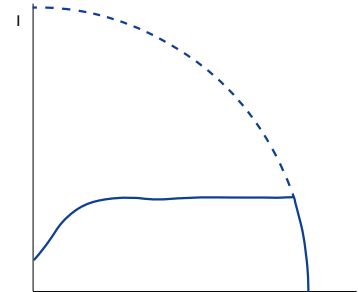

Current diagram with soft starter

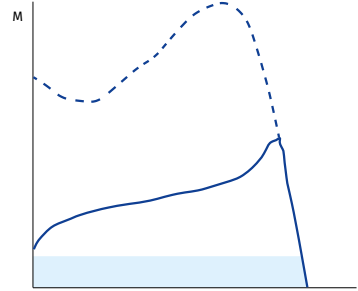

Torque diagram with soft starter

APPLICATIONS IN VENTILATION SYSTEMS

Using an FC or a soft starter allows to reduce the starting current thereby avoiding a loss of voltage in the electrical mains.

In addition to that the starting torque and mechanical strain on equipment are also reduced which translates into extended maintenance and repair intervals.

General exhaust ventilation (GV) systems and emergency smoke extraction (SE) systems of car parks, warehouses, utility and industrial spaces can be integrated into a single system at the design level.

As the air flow rate a GV system is considerably lower than that in an SE system a high-capacity fan rated for smoke extraction duty runs in partial load mode.

Frequency converters can be programmed for several fixed-speed settings to enable operation in GV and SE modes.

The fan operating modes can be switched upon receiving an external signal from the control system.

Such integration of ventilation systems allows overall cost savings.

FC-51 AND FC-101: WHEN TO USE?

This catalogue features two series of frequency converters: FC-51 and FC-101.

The FC-51 series is only suitable for general ventilation systems.

If intended for a smoke extraction system, the fans should be fitted with the FC-101 series units as they feature an integrated fire mode.

When activated the integrated protection equipment of the frequency converter is overridden enabling the unit to continue operation despite the possibility of sustaining irreparable damage due to overheating or overloading.

In case of a fire, the FC-101 series frequency converters are capable of maintaining a higher air pressure level at landings compared to other areas of the building in order to keep the landings smoke-free.

MICRO DRIVE FC-51

Frequency converters



Use

- o This general-purpose variable frequency drive is designed for regulating the rotation speed of an AC electric motor with a maximum power output of 22 kW.
- o This unit is only suitable for general ventilation systems.

Features

- o The drive construction prevents forced air flow passage through its internal electronic components.
- o The internal circuit boards are well-protected.

Filter

- o The unit features an integrated HF filter which blocks RF interference from the motor and enables the use of a shielded cable up to 15 m long or unshielded cable up to 50 m long as per the applicable EU regulations.

Inputs and outputs

- o 5 programmable digital inputs
- o PNP/NPN logic
- o 20-5000 Hz pulse input
- o One 0-10 V or 0-20 mA analogue input
- o One 0-20 mA analogue input
- o Thermistor input (analogue or digital)
- o 1 analogue output
- o 1 relay, 240 V, 2 A
- o RS 485
- o MODBUS RTU

Control panels



| Designation | Code |
|--|----------|
| VLT control panel LCP 11 (without potentiometer) | 132B0100 |
| VLT Control Panel LCP 12 (with potentiometer) | 132B0101 |



| Designation | Code |
|---------------------------|----------|
| Remote panel mounting kit | 132B0102 |

Installation

- o Back-to-back installation for space savings. Thanks to a compact design the drives can be mounted immediately next to one another without any performance penalties.

Frequency converter type and order code

| Three-phase, 380-480 V | | | |
|------------------------|-------------------|------------|------------|
| Power [kW] | Rated current [A] | Order code | Block type |
| 0.37 | 1.2 | 132F0017 | M1 |
| 0.75 | 2.2 | 132F0018 | M1 |
| 1.5 | 3.7 | 132F0020 | M2 |
| 2.2 | 5.3 | 132F0022 | M2 |
| 3.0 | 7.2 | 132F0024 | M3 |
| 4.0 | 9.0 | 132F0026 | M3 |
| 5.5 | 12.0 | 132F0028 | M3 |
| 7.5 | 15.5 | 132F0030 | M3 |
| 11.0 | 23.0 | 132F0058 | M4 |
| 15.0 | 31.0 | 132F0059 | M4 |
| 18.0 | 37.0 | 132F0060 | M5 |
| 22.0 | 43.0 | 132F0061 | M5 |

Outside dimensions (including mounting ledge)

| mm | M1 | M2 | M3 | M4 | M5 |
|--------|-----|-----|-----|-----|-----|
| Height | 150 | 176 | 239 | 292 | 335 |
| Width | 70 | 75 | 90 | 125 | 165 |
| Depth | 148 | 168 | 194 | 241 | 248 |

+ 6 mm with potentiometer

BASIC DRIVE FC-101

Frequency converters



Use

- This general-purpose variable frequency drive is designed for regulating the rotation speed of an AC electric motor with a maximum power output of 90 kW.
- This drive is suitable for both general ventilation and smoke extraction ventilation systems.

Certified fire mode

- The fire mode prevents the drive from a self-protecting shut-down. While in this mode the drive continues to perform speed regulation duty for mission-critical fans irrespective of control signals, warnings and alarms which may otherwise force it shut down.

Filter

- A built-in throttle on the DC link ensures a low harmonic load on the power mains as per the EN 61000-3-12 standard requirements.

Inputs and outputs

- Four PNP or NPN programmable digital inputs, 0-24 V DC
- 2 analogue inputs (0-10 V or 0/4-20 mA)
- 2 analogue outputs (0/4-20 mA)
- 2 relay outputs
- MODBUS RTU (RS 485)
- BACnet MSTP
- FC Protocol
- N2 Metasys
- FLN Apogee

Installation

- Thanks to an ultra-compact design the drive can be easily fitted into a larger unit or panel of an air ventilation system. The casings are rated IP20/Type 1/IP21 (optional) and IP54.

Frequency converter type and SKU code

| Power [kW] | Current [A] | VLT® FC 101 HVAC Basic Drive 0.37-90 kW (3 x 380 – 480 V~, without a braking transistor) | | | |
|---------------|--|--|--|---|----------|
| 0.37 | 1.2 | - | 131L9861 | - | - |
| 0.75 | 2.2 | - | 131L9862 | 131N0177 | 131N0178 |
| 1.5 | 3.7 | - | 131L9863 | 131N0179 | 131N0180 |
| 2.2 | 5.3 | - | 131L9864 | 131N0181 | 131N0182 |
| 3 | 7.2 | - | 131L9865 | 131N0183 | 131N0184 |
| 4 | 9.1 | - | 131L9866 | 131N0185 | 131N0186 |
| 5.5 | 12 | - | 131L9867 | 131N0187 | 131N0188 |
| 7.5 | 15.5 | - | 131L9868 | 131N0189 | 131N0190 |
| 11 | 23 | - | 131L9869 | 131N0191 | 131N0192 |
| 15 | 31 | - | 131L9870 | 131N0193 | 131N0194 |
| 18 | 37 | - | 131L9871 | 131N0195 | 131N0196 |
| 22 | 42.5 | - | 131L9872 | 131N0197 | 131N0198 |
| 30 | 61 | 131L9873 | 131L9875 | 131N0201 | 131N0202 |
| 37 | 73 | 131L9881 | 131L9883 | 131N0205 | 131N0206 |
| 45 | 90 | 131L9889 | 131L9891 | 131N0209 | 131N0210 |
| 55 | 106 | 131L9897 | 131L9899 | 131N0213 | 131N0214 |
| 75 | 147 | 131L9905 | 131L9907 | 131N0217 | 131N0218 |
| 90 | 177 | 131L9913 | 131L9915 | 131N0221 | 131N0222 |
| Casing | (E20) IP20/Chassis | (E20) IP20/Chassis | IP54 | IP54 | |
| EMC filter | (H2) RFI class A2 (for industrial areas) | (H3/H4) RFI class A1/B (for residential areas) | (H2) RFI class A2 (for industrial areas) | (H3) RFI class A1/B (for residential areas) | |
| Control panel | (X) without panel | (X) without panel | Integral | Integral | |

VLT® HVAC Basic frequency converters rated up to 22 kW are fitted with circuit boards with a special class 3C3 protective coating. For frequency converters rated higher than 22 kW this protective coating is optional while, the 3C2 coating is standard.

VLT® FC 101 HVAC Basic Drive frequency converter options

| Order code | Description |
|------------|---|
| 132B0200 | Operator's digital panel |
| 132B0201 | Kit for remote mounting of the operator panel to an IP55 cabinet, including 3 m cable |
| 132B0202 | Decoupling plate for H1 and H2 standard sizes |
| 132B0204 | Decoupling plate for H3 standard size |
| 132B0205 | Decoupling plate for H4 and H5 standard sizes |
| 132B0207 | Decoupling plate for H6 standard size |
| 132B0242 | Decoupling plate for H6 standard size (extra large) |

| Order code | Description |
|------------|--|
| 132B0208 | Decoupling plate for H7 standard size |
| 132B0243 | Decoupling plate for H7 standard size (extra large) |
| 132B0209 | Decoupling plate for H8 standard size |
| 132B0244 | External EMC filter class A1/B1 for power output from 0.37 to 2.2 kW |
| 132B0245 | External EMC filter class A1/B1 for power output from 3 to 7.5 kW |
| 132B0246 | External EMC filter class A1/B1 for power output from 11 to 15 kW |
| 132B0247 | External EMC filter class A1/B1 for power output from 18.5 to 22 kW |

Blauberg Ventilatoren GmbH
Aidenbachstr. 52
D-81379 Munich

info@blaubergventilatoren.de
www.blaubergventilatoren.de

Technical changes reserved.
Illustrations and texts are non-binding.